

# WI Line

## WIC1

### SELF-/DUAL-POWERED PROTECTION DEVICE

- WIC1-1 | Self-powered device, parameter settings via DiggiMEC / Smart view
- WIC1-2 | Self-powered device, parameter settings via DIP switches and/or DiggiMEC / Smart view
- WIC1-3 | Self-powered device, parameter settings via HEX switches and/or DiggiMEC / Smart view
- WIC1-4 | Dual-powered device, parameter settings via DiggiMEC / Smart view

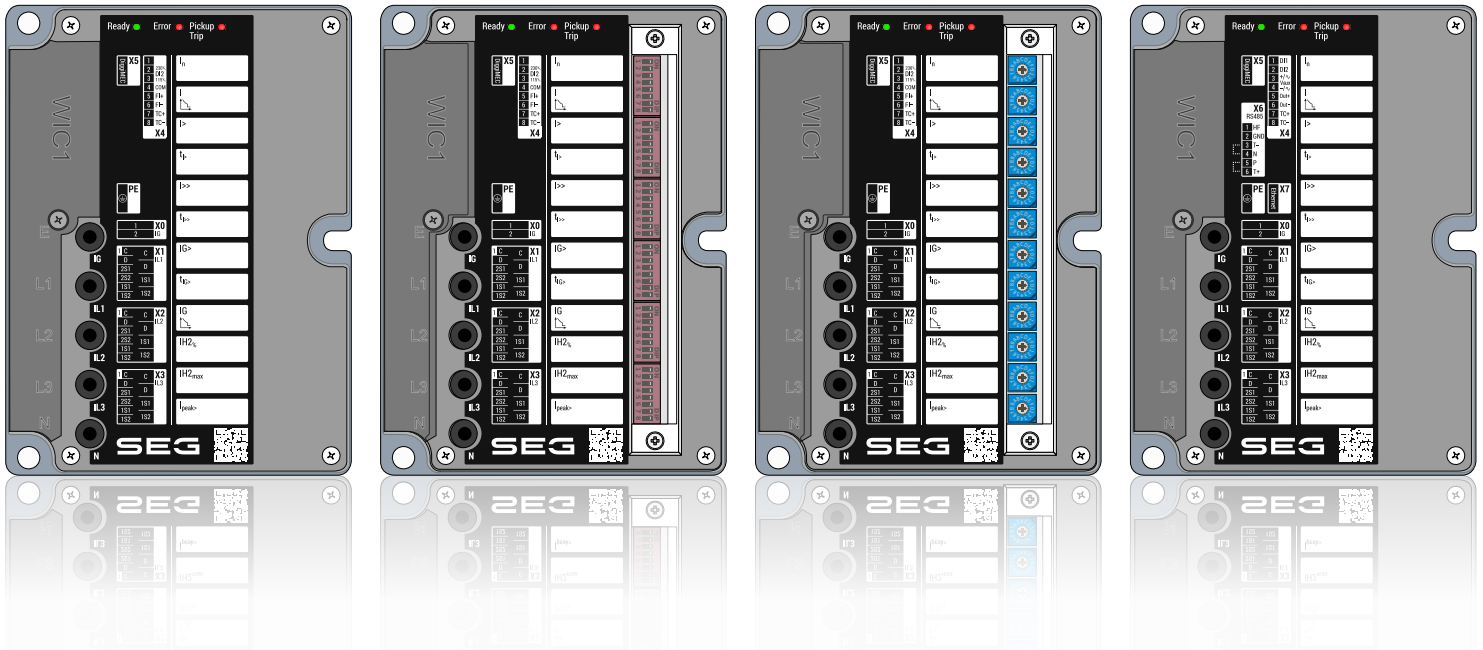

### SELF-/DUAL-POWERED PROTECTION DEVICE

Version: 2.0

Original document

English

**MANUAL WIC1-2.0-EN-MAN**

Build 58110

Revision B

Manual

**SEG Electronics GmbH**

Krefelder Weg 47 • D-47906 Kempen (Germany)

Telephone: +49 (0) 21 52 145 1

Internet: [www.SEGelectronics.de](http://www.SEGelectronics.de)

Sales

Telephone: +49 (0) 21 52 145 331

Fax: +49 (0) 21 52 145 354

E-mail: [sales@SEGelectronics.de](mailto:sales@SEGelectronics.de)

Service

Telephone: +49 (0) 21 52 145 600

Fax: +49 (0) 21 52 145 354

E-mail: [support@SEGelectronics.de](mailto:support@SEGelectronics.de)

SEG Electronics GmbH reserves the right to update any portion of this publication at any time.

Information provided by SEG Electronics GmbH is believed to be correct and reliable.

However, no responsibility is assumed by SEG Electronics GmbH unless otherwise expressly undertaken.

© 2022 SEG Electronics GmbH. All rights reserved.

# Table of Contents

<b>1</b>	<b>Safety Messages and Proper Use of the WIC1</b>	<b>12</b>
1.1	Important Definitions	12
1.2	Proper Use of the Device and of This Manual	13
1.3	Personal Safety	16
1.4	Important Information	17
<b>2</b>	<b>WIC1 - Introduction, Operation</b>	<b>18</b>
2.1	Basic Wiring Concept	20
2.2	Operating Concept for the WIC1	22
2.3	Supply of a WIC1	23
2.4	WIC1 Protection Features	25
2.4.1	Functional Overview	25
2.4.2	Device Features	26
2.5	Comments on the Manual	28
2.5.1	Symbols in Function Diagrams	29
2.6	Information About the Device	32
2.6.1	Order Form of the Device	33
2.6.1.1	Order Form of the CT-Powered Device Types	34
2.6.1.2	Order Form of the Dual-Powered WIC1-4	36
2.6.1.3	Order Form of the WIC1-Compatible Current Transformers	38
2.6.1.4	Order Form WI1SZ4	39
2.6.1.5	Order Form WI1SZ5	39
2.6.1.6	Order Form of the DiggiMEC	40
2.7	Settings - Operation	41
2.7.1	Smart view	43
2.8	Device Planning	44
2.9	Modules, Settings, Signals and Values	46
2.10	Measuring Values	48
2.11	Condition Monitoring (Peak Current Ptr, Life Load)	50
2.12	Reset	51
2.12.1	Automatic Reset	52

2.12.2	Notification of a Problem via LED . . . . .	53
2.13	Reset to Factory Defaults . . . . .	54
2.14	Security . . . . .	55
2.14.1	Password . . . . .	55
<b>3</b>	<b>Hardware . . . . .</b>	<b>56</b>
3.1	Overview of Elements and Connectors . . . . .	56
3.1.1	Terminals, Screws and Torques . . . . .	59
3.2	Dimension Drawings . . . . .	60
3.2.1	WIC1 Dimension Drawings . . . . .	60
3.2.2	DiggiMEC Dimension Drawings . . . . .	62
3.2.3	Dimension Drawings of the WIC1-Compatible Current Transformers . . . . .	64
3.2.4	Dimension Drawing of the Flag Indicator WI1SZ5 . . . . .	69
3.3	WIC1 - Installation and Wiring . . . . .	70
3.3.1	Grounding . . . . .	70
3.3.1.1	Nut "PE" for Grounding . . . . .	71
3.3.2	Selection of a WIC1-Compatible Current Transformer . . . . .	72
3.3.2.1	Current Ranges of the WIC1-CTs . . . . .	73
3.3.2.2	CT Type WE2 . . . . .	74
3.3.2.3	Selection of the CT Transformation Voltage Ratio . . . . .	74
3.3.3	Adapter CTs for 1 A / 5 A . . . . .	77
3.3.3.1	Requirements for Standard CTs . . . . .	79
3.4	Phase and Ground Current Measuring Inputs . . . . .	81
3.4.1	Current Measuring Inputs for WIC1-CTs and Without Ground Current Input . . . . .	83
3.4.2	Current Measuring Inputs for WIC1-CTs With Ground Current Input . . . . .	84
3.5	Digital Input (only WIC1-1... / WIC1-2... / WIC1-3...) . . . . .	85
3.6	Additional Power Supply and Digital Inputs (WIC1-4... only) . . . . .	86
3.7	Serial Interface RS485 (WIC1-4... only) . . . . .	88
3.8	Outputs (Trip Coil, Flag Indicator, Relay Output) . . . . .	92
3.8.1	Self-Supervision Contact for the WIC1-4 . . . . .	95
3.8.2	Connecting a Flag Indicator to the WIC1 . . . . .	96
3.8.3	Impulse Signal for the Flag Indicator . . . . .	98
3.9	Input, Output and LED Settings . . . . .	99

3.9.1	LEDs	99
3.9.1.1	WIC1-LED for “Pickup / TripCmd”	102
3.9.1.2	LED Configuration (DiggiMEC)	102
3.9.1.3	Latching of the DiggiMEC LEDs	102
3.9.1.4	Latching of a DiggiMEC-LED with an Assigned Trip Signal	104
3.9.2	Configuration of the Digital Inputs	106
3.9.3	Date and Time	107
3.10	DiggiMEC® - Nano HMI with Flag Indicators and Output Relays	108
3.10.1	Navigation - Operation	110
3.10.1.1	Front Panel Parts	110
3.10.1.2	Favoriten-Taste »★«	113
3.10.1.3	Special Keys During Power-on	115
3.10.1.4	Menu Structure	116
3.10.1.5	Parameter Changes - “OK” key	118
3.10.1.6	Operation via Smart view	121
3.10.2	DiggiMEC Connectors	123
3.10.3	Flag Indicator / Output Relays Settings (DiggiMEC)	127
3.10.3.1	Latching	128
3.10.3.2	Testing the Flag Indicators / Output Relays	129
<b>4</b>	<b>Communication Protocols (WIC1-4 only)</b>	<b>130</b>
4.1	Modbus® (WIC1-4 only)	130
<b>5</b>	<b>Protective Elements</b>	<b>132</b>
5.1	»Prot« - General Protection Module	132
5.1.1	General Pickup, General Alarm, General Trip	134
5.1.1.1	Trip Pulse and WIC1 LEDs	135
5.1.1.2	Phase-Selective Signals, Collective Signals	137
5.1.2	Force Trip Command	139
5.1.3	Blockings	140
5.1.3.1	Switching Protection Functions On or Off	140
5.1.3.2	Temporary Blocking	141
5.1.4	Control of a Switchgear	142
5.1.4.1	Switchgear Configuration	142

5.2	Field Parameters . . . . .	147
5.2.1	Field Parameter Settings via DiggiMEC or via Smart view . . . . .	147
5.3	I>, I>>, I>>> – Phase Overcurrent Protection . . . . .	149
5.3.1	Functionality . . . . .	150
5.3.2	Phase Overcurrent Protection – Settings . . . . .	152
5.3.2.1	Phase Overcurrent Protection – Settings via DiggiMEC or via Smart view . . . . .	153
5.4	IH2 - Inrush Blocking . . . . .	155
5.4.1	Functionality . . . . .	156
5.4.2	Inrush – Settings . . . . .	157
5.4.2.1	Inrush – Settings via DiggiMEC or via Smart view . . . . .	157
5.4.3	Commissioning: Inrush . . . . .	158
5.5	IG>, IG>> – Earth (Ground) Overcurrent Protection . . . . .	159
5.5.1	Functionality . . . . .	160
5.5.2	Earth (Ground) Overcurrent Protection – Settings . . . . .	161
5.5.2.1	Earth (Ground) Overcurrent Protection – Settings via DiggiMEC or via Smart view . . . . .	162
5.6	I2/I1> – Unbalanced Load [46] . . . . .	164
5.6.1	Functionality . . . . .	165
5.6.2	Current Unbalance Protection – Settings via DiggiMEC or via Smart view . . . . .	166
5.7	I2> – Negative-Sequence Current Protection [51Q] . . . . .	167
5.7.1	Functionality . . . . .	168
5.7.2	Settings via DiggiMEC or via Smart view . . . . .	169
5.8	ThR – Thermal Overload [49] . . . . .	171
5.8.1	Functionality . . . . .	172
5.8.2	Thermal Overload – Settings via DiggiMEC or via Smart view . . . . .	173
5.9	Ipeak> – Peak Overcurrent Protection . . . . .	174
5.9.1	Functionality . . . . .	175
5.9.2	Ipeak> – Settings . . . . .	176
5.9.2.1	Ipeak> – Settings via DiggiMEC or via Smart view . . . . .	176
5.10	SOTF - Switch Onto Fault . . . . .	177
5.10.1	SOTF – Settings via DiggiMEC or via Smart view . . . . .	179
5.11	CLPU - Cold Load Pickup (WIC1-4 only*) . . . . .	180
5.11.1	Functionality . . . . .	182

5.11.2	CLPU – Settings via DiggiMEC or via Smart view . . . . .	182
5.12	ExP – External Protection . . . . .	184
5.12.1	Functionality . . . . .	185
5.12.2	External Protection – Settings via DiggiMEC or via Smart view . . . . .	186
5.13	CBF – Circuit Breaker Failure [50BF, 62BF] . . . . .	187
5.13.1	Principle – General Use . . . . .	187
5.13.2	States / Standby . . . . .	188
5.13.3	Functionality . . . . .	188
5.14	Integrated Backup Phase Overcurrent Protection . . . . .	189
5.14.1	Activation of the Backup Protection . . . . .	190
5.15	Supervision . . . . .	191
5.15.1	BkrWear . . . . .	191
5.15.1.1	BkrWear – Settings via DiggiMEC or via Smart view . . . . .	193
5.15.1.2	Functionality . . . . .	195
5.15.2	»TCM« – Trip Circuit Monitoring [74TC] . . . . .	196
5.15.3	Condition Monitoring – Life Load . . . . .	197
5.15.4	Condition Monitoring – Peak Current Pointer . . . . .	199
<b>6</b>	<b>Fault Recorder . . . . .</b>	<b>201</b>
6.1	Fault Display screen (Overlay / Pop-up) on the DiggiMEC . . . . .	203
6.2	Content of a Fault Record . . . . .	205
6.3	How to Read Out the Fault Recorder . . . . .	206
<b>7</b>	<b>Self-Supervision . . . . .</b>	<b>207</b>
7.1	Device Start (Reboot) . . . . .	208
7.2	Self-Supervision Messages . . . . .	209
<b>8</b>	<b>Commissioning . . . . .</b>	<b>211</b>
8.1	Commissioning / Protection Test . . . . .	212
8.1.1	Special Features of the WIC1 Test . . . . .	213
8.1.2	Selection of the Secondary Test System . . . . .	213
8.1.3	Measurement of the Resistive Burden . . . . .	214
8.1.4	Checks During Commissioning . . . . .	214
8.1.4.1	Test Windings, Test Sockets . . . . .	215

8.1.4.2	Wiring Checks . . . . .	217
8.1.4.3	Self-Supervision Contact for the WIC1-4 . . . . .	218
8.1.4.4	WIC1 Settings . . . . .	218
8.1.5	Functional Test . . . . .	218
8.1.5.1	Test Currents . . . . .	219
8.1.5.2	Pickup Thresholds for the Phase Overcurrent Stage I> . . . . .	220
8.1.5.3	Pickup Thresholds for the Short-Circuit (Phase Overcurrent) Stage I>> . . . . .	221
8.1.6	Special Features for Tests of Calculated Ground (Earth) Overcurrent . . . . .	222
8.1.6.1	Tripping Thresholds for the Calculated Ground Overcurrent Stage IG> . . . . .	223
8.2	Putting out of Operation – Plug out the Relay . . . . .	225
8.3	Restart of the WIC1 . . . . .	225
8.4	Measuring the Trip Delay . . . . .	226
<b>9</b>	<b>Servicing and Maintenance . . . . .</b>	<b>228</b>
<b>10</b>	<b>Technical Data . . . . .</b>	<b>229</b>
10.1	Technical Data – WIC1 . . . . .	229
10.1.1	Climatic and Environmental Data . . . . .	229
10.1.2	Housing . . . . .	229
10.1.3	Degree of Protection EN 60529 . . . . .	229
10.1.4	Phase Current Measurement . . . . .	230
10.1.5	Ground Current Measurement . . . . .	230
10.1.6	Power Supply . . . . .	231
10.1.7	LEDs . . . . .	231
10.1.8	Outputs . . . . .	231
10.1.8.1	Impulse Output for the Tripping Coil . . . . .	232
10.1.8.2	Impulse Output for a Flag Indicator . . . . .	232
10.1.8.3	Relay Output (WIC1-4) . . . . .	233
10.1.9	Remote (External) Trip Input / Digital Input (WIC1-1, WIC1-2, WIC1-3) . . . . .	233
10.1.10	Digital Inputs (WIC1-4) . . . . .	234
10.1.11	Smart view Connections . . . . .	234
10.1.12	Self-Supervision Messages . . . . .	235
10.1.13	Standards – WIC1 . . . . .	236
10.1.13.1	Approvals . . . . .	236



10.1.13.2	Design Standards . . . . .	237
10.1.13.3	Electrical Tests . . . . .	238
10.1.13.4	Safety-Related Tests . . . . .	240
10.1.13.5	Environmental Tests . . . . .	241
10.2	Tolerances / Accuracy – WIC1 . . . . .	243
10.2.1	Protection Elements Accuracy . . . . .	243
10.2.1.1	Phase Overcurrent Protection . . . . .	243
10.2.1.2	Ground (Earth) Overcurrent Protection . . . . .	245
10.2.1.3	Unbalanced Load [46], Negative-Sequence Current Protection [51Q] . . . . .	247
10.2.1.4	Peak Overcurrent Protection . . . . .	248
10.2.1.5	Inrush Blocking . . . . .	249
10.2.1.6	Switch Onto Fault (SOTF) . . . . .	249
10.2.1.7	Thermal Overload Protection . . . . .	250
10.2.1.8	External Protection . . . . .	250
10.2.2	Measured Trip Times (fN = 50 Hz, 1-/3-phase) . . . . .	251
10.3	Technical Data – DiggiMEC . . . . .	253
10.3.1	Climatic and Environmental Data . . . . .	253
10.3.2	Housing . . . . .	253
10.3.3	Degree of Protection EN 60529 . . . . .	254
10.3.4	Voltage Supply . . . . .	254
10.3.5	Binary Output Relays . . . . .	254
10.3.6	Standards – DiggiMEC . . . . .	255
10.3.6.1	Approvals . . . . .	255
10.3.6.2	Design Standards . . . . .	256
10.3.6.3	Electrical Tests . . . . .	257
10.3.6.4	Safety-Related Tests . . . . .	259
10.3.6.5	Environmental Tests . . . . .	260
10.4	Technical Data – WIC1 CTs . . . . .	261
10.4.1	Technical Data – WIC1 CTs, Construction Type 1 . . . . .	261
10.4.2	Technical Data – WIC1 CTs, Construction Type 2 . . . . .	261
10.4.3	Technical Data – Adapter CTs for 1 A, 5 A . . . . .	263
10.4.4	Test Windings, Test Sockets . . . . .	264

10.5	Technical Data – WI1SZ4 .....	265
10.6	Technical Data – WI1SZ5 .....	266
<b>11</b>	<b>Troubleshooting .....</b>	<b>267</b>
11.1	In Case You Need to Contact Our Service-Team .....	267
11.2	Self-Supervision Messages .....	268
11.2.1	Self-Supervision – Error Messages .....	269
11.2.2	Self-Supervision – Warning Messages .....	270
11.2.3	Self-Supervision – Information Messages .....	272
11.3	Signals via LEDs (at WIC1 or DiggiMEC) .....	273
11.4	Problems with the Device .....	275
11.4.1	Hardware .....	275
11.4.2	Operation of the Device .....	277
11.4.3	Parameter Settings .....	278
11.4.4	Protection and Control .....	279
11.4.5	Communication .....	280
<b>12</b>	<b>Appendix .....</b>	<b>282</b>
12.1	Appendix – Settings via DIP / HEX Switches .....	282
12.1.1	Settings via DIP Switches (WIC1-2) .....	282
12.1.2	Settings via HEX Switches (WIC1-3) .....	286
12.1.3	Setting of the Rated CT current In .....	290
12.1.3.1	DIP-/HEX-Switch Settings for CT Types W2, WE2 .....	291
12.1.3.2	DIP-/HEX-Switch Settings for CT Type W3 .....	292
12.1.3.3	DIP-/HEX-Switch Settings for CT Type W4 .....	293
12.1.3.4	DIP-/HEX-Switch Settings for CT Type W5 .....	294
12.1.3.5	DIP-/HEX-Switch Settings for CT Type W6 .....	295
12.1.4	Phase Overcurrent Protection – Settings via DIP Switches (WIC1-2) or via HEX Switches (WIC1-3) .....	296
12.1.5	Earth (Ground) Overcurrent Protection – Settings via DIP Switches (WIC1-2) or via HEX Switches (WIC1-3) .....	301
12.1.6	Inrush – Settings via DIP Switches (WIC1-2) or via HEX Switches (WIC1-3) .....	303
12.1.7	I <sub>peak</sub> > – Settings via DIP Switches (WIC1-2) or via HEX Switches (WIC1-3) .....	306
12.2	Appendix – Time Overcurrent Characteristics .....	307

12.2.1	Characteristics (I>, I>>, I>>>)	307
12.2.1.1	DEFT - Definite Time-Overcurrent (I>, I>>, I>>>)	309
12.2.1.2	Inverse-Time Characteristics (I>, I>>, I>>>)	310
12.2.2	Characteristics (IG>, IG>>)	325
12.2.2.1	DEFT - Definite Time-Overcurrent (IG>, IG>>)	327
12.2.2.2	Inverse-Time Characteristics (IG>, IG>>)	328
12.2.3	Characteristics »I2>«	344
12.2.3.1	DEFT - Definite Time-Overcurrent (»I2>«)	346
12.2.3.2	Inverse-Time Characteristics (»I2>«)	347
12.3	Requirements for 1 A/5 A Standard CTs with WIC1 Adapter CTs	362
12.4	Revision History	364
12.4.1	Version: 1.0	365
12.4.2	Version: 1.1	366
12.4.3	Version: 2.0	367
<b>13</b>	<b>Index</b>	<b>368</b>

# 1 Safety Messages and Proper Use of the WIC1

## 1.1 Important Definitions

The types of messages shown below serve the safety of life and limb as well as for the appropriate operating life of the device.

### DANGER!



DANGER! indicates an immediately dangerous situation that will result in death or serious injury if it is not avoided.

### WARNING!



WARNING! indicates a hazardous situation that can result in death or serious injury if it is not avoided.

### CAUTION!



CAUTION! indicates a possibly hazardous situation that can result in minor or moderate injuries if it is not avoided.

### NOTICE!



NOTICE! is used to address practices not related to personal injury.



This symbol indicates useful tips and recommendations as well as information for efficient and trouble-free operation.

## 1.2 Proper Use of the Device and of This Manual

### CAUTION!



Do not put the WIC1 in service until it has been configured and commissioned.

Read the User Manual.

For configuring the required protection functions, read the related chapters within [↪ “5 Protective Elements”](#).

In this context, it is also important to refer to the general [↪ “5.1 »Prot« - General Protection Module”](#).

For commissioning, read [↪ “8 Commissioning”](#) and the “Commissioning” sections within the chapters that are related to the required protection functions.

### WARNING!



FOLLOW INSTRUCTIONS

Read this entire manual and all other publications pertaining to the work to be performed before installing, operating, or servicing this equipment. Practice all plant and safety instructions and precautions. Failure to follow instructions can cause personal injury and/or property damage.

**WARNING!**



**PROPER USE**

Any unauthorized modifications to or use of this equipment outside its specified mechanical, electrical, or other operating limits may cause personal injury and/or property damage, including damage to the equipment. Any such unauthorized modifications: (1) constitute “misuse” and/or “negligence” within the meaning of the product warranty thereby excluding warranty coverage for any resulting damage, and (2) invalidate product certifications or listings.

The programmable devices subject to this manual are designed for protection and also control of power installations and operational devices that are fed by voltage sources with a fixed frequency, i. e. fixed at 50 or 60 Hertz. They are not intended for use with Variable Frequency Drives. The devices are further designed for installation in low-voltage (LV) compartments of medium voltage (MV) switchgear panels or in decentralized protection panels. The programming and parameterization have to meet all requirements of the protection concept (of the equipment that is to be protected). You must ensure that the device will properly recognize and manage (e. g. switch off the circuit breaker) on the basis of your programming and parameterization all operational conditions (failures). The proper use requires a backup protection by an additional protective device. Before starting any operation and after any modification of the programming (parameterization) test make a documentary proof that your programming and parameterization meets the requirements of your protection concept.

Typical applications for this product family/device line are for instance:

- Feeder protection
- Mains protection
- Machine protection
- Transformer Protection
- Generator Protection

Any usage beyond these applications the devices are not designed for. This applies also to the use as a partly completed machinery. The manufacturer cannot be held liable for any resulting damage, the user alone bears the risk for this. As to the appropriate use of the device: The technical data and tolerances specified by *SEG* have to be met.

**WARNING!**



The bistable output relays of a DiggiMEC, that is connected to the WIC1, may be used only for visualization purposes. It is not permitted to use these relay contacts for any protection-related and/or switching purposes!

If the DiggiMEC relays are used for switching purposes there is the risk of an unreliable protection of your application!

Only the trip-coil output “TC+/-” of the WIC1 may be used for tripping a breaker.

(Further remarks can be found in [↳ Chapter 3.10.2.](#))

### WARNING!



Ensure that the actual overcurrent settings comply with the technical and thermal limits of the device, the CTs and the application!

Check the technical data ([↗](#) “10.1 Technical Data - WIC1”) for the permitted current input limits. When defining the protection settings, note that both current threshold and (delay) time must be set in consideration of the technical input limits.

- The thermal load capacity of the phase current inputs can be found here: [↗](#) “10.1.4 Phase Current Measurement”. The diagram and table in [↗](#) “3.3.2 Selection of a WIC1-Compatible Current Transformer” might also be useful.
- The thermal load capacity of the ground (earth) current inputs can be found here: [↗](#) “10.1.5 Ground Current Measurement”.

Unless there are any additional/external protective means installed we have to recommend that you activate at least one phase overcurrent protection stage considering the WIC1 limits ( $2.5 \cdot I_{n,max}$  for 2.5 s, 25 kA for 1 s).

If your WIC1 features a ground (earth) current measuring input, these considerations should be applied in the same manner for one of the two ground overcurrent protection stages »IG>«, »IG>>«.

Ignoring the permitted limits will damage the WIC1, making it non-functional, and this can possibly result in serious damages of your equipment and even serious injury.

### WARNING!



After connecting the terminals (see also the separate “Wiring Diagrams” document), make sure to fix the plastic cover again. (See [↗](#) “3.1.1 Terminals, Screws and Torques” for the correct torque of the non-losable screw.)

The cover protects against inadvertently touching the contacts. Moreover, some WIC1 have an additional sticker with wiring information that should not get lost.

### 1.3 Personal Safety

**DANGER!**



Ignoring the following safety messages can result in death or serious injury or physical damage.

**DANGER!**



Only qualified electricians may install, commission, work or operate this device.

All national standards - if applicable - must be followed.

**DANGER!**



The terminal block for connection to the current transformers is not a shorting block. Therefore always short-circuit current transformers before loosening the terminals.

Ignoring this can result in dangerous voltages at the open contacts (up to dozens of kilovolts depending on the CT type).

**DANGER!**



Even when the auxiliary voltage is switched off, it is likely that there are still hazardous voltages at the component connections.

Upon opening the device, it is likely that some parts with high voltages become accessible. Touching these is dangerous to life.

The device must be carefully grounded. See [↪ "3.3.1 Grounding"](#).



## 1.4 Important Information

### NOTICE!



The devices are manufactured and delivered according to the **order code** specified by the customer.

### CAUTION!



All electronic equipment is electrostatic-sensitive, some components more than others. To protect these components from electrostatic damage, you must take special precautions to minimize or eliminate electrostatic discharges. Follow these precautions when working with or near the control:

1. Before doing maintenance on the electronic control, discharge the static electricity on your body to ground by touching and holding a grounded metal object (pipes, cabinets, equipment, etc.).
2. Avoid the build-up of static electricity on your body by not wearing clothing made of synthetic materials. Wear cotton or cotton-blend materials as much as possible because these do not store static electric charges as much as synthetics.
3. Keep plastic, vinyl, and Styrofoam materials (such as plastic or Styrofoam cups, cup holders, cigarette packages, cellophane wrappers, vinyl books or folders, plastic bottles, and plastic ash trays) away from the control, the modules, and the work area as much as possible.

The WIC1 does not contain any parts that can be fixed or adjusted by the user. The housing is hermetically sealed and cannot be opened without causing damage.

Any unauthorized opening of the device will void the warranty.

### ***Out-of-Date Documentation?***



This publication may have been revised or updated since this copy was produced. To verify that you have the latest revision, please visit the download section of our website:

- **<https://docs.SEGelectronics.de/wic1>**

Please check this download area for the latest revision of this Technical Manual and whether there is an Errata Sheet with updated information. (The ID of every document is printed on its cover page.)

## 2 WIC1 - Introduction, Operation

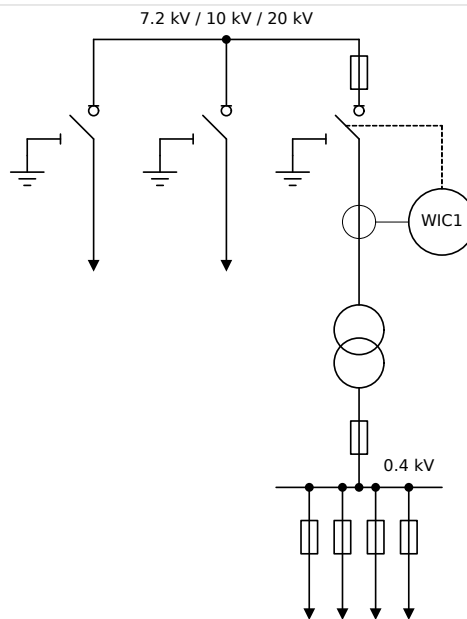

WIC1\_Z17

Fig. 1: Basic circuit diagram of a standard switchboard with 2 feeders and 1 outgoing transformer panel.

### Introduction

The WIC1 is a CT-powered protection relay with inverse time and definite time protection characteristics and is specifically designed for switchboards with CBs and small rated output currents.

Together the specific CTs and the WIC1 form a joint protective system. A low-energy coil is needed for realizing trip of the CB.

The generation 2 of the WIC1 (also, short: WIC1 g2), that is described in this document, is the successor protection device of SEG's well-established WIC1 (for differentiation also: WIC1 g1), that is reliably in service within hundreds of thousands of MV switchboards.

The requirements on MS distribution stations with circuit breakers call for a robust protection relay which is optimized accordingly and an integral part of the respective switchboard. The WIC1 is a time-overcurrent relay that SEG has developed specifically for such requirements.

The WIC1 is a CT-powered protection relay with minimal space requirement, that complies with the highest demands on a digital protection device. Simple but safe wiring, high electromagnetic interference immunity, uncomplicated adjustment and the ability to scale to different power quantities of the switchboard, helping the switchgear manufacturer to minimize costs. The WIC1 represents a protective system with a guaranteed maintenance-free period of 25 years, the same as for the switchboard.

The SEG protection relays of the WI Line are offering time-overcurrent protective functions and earth fault protective functions in the well-proven technique for CT-powered protection relays.

As a CT-powered protection relay the WIC1 is mainly used in MV switchboards with circuit breakers, protecting distribution transformers in local and industrial networks. Due to its small size the WIC1 is very well suited for the use in compact switchboards.

The ability of the protection system WIC1 to adapt to different primary currents makes it possible that it is used for all standard rated transformer loads and the different medium voltage operational voltages.

The WIC1 is also available in device variants that can optionally be supplied with external power (so-called "Dual-Powered" WIC1). A stable external power supply allows for further functionality, e.g. SCADA communication. (See also [↳ "2.6.1 Order Form of the Device"](#).)



An overview of the elements and connectors can be found here: [↳ "3.1 Overview of Elements and Connectors"](#)

## 2.1 Basic Wiring Concept

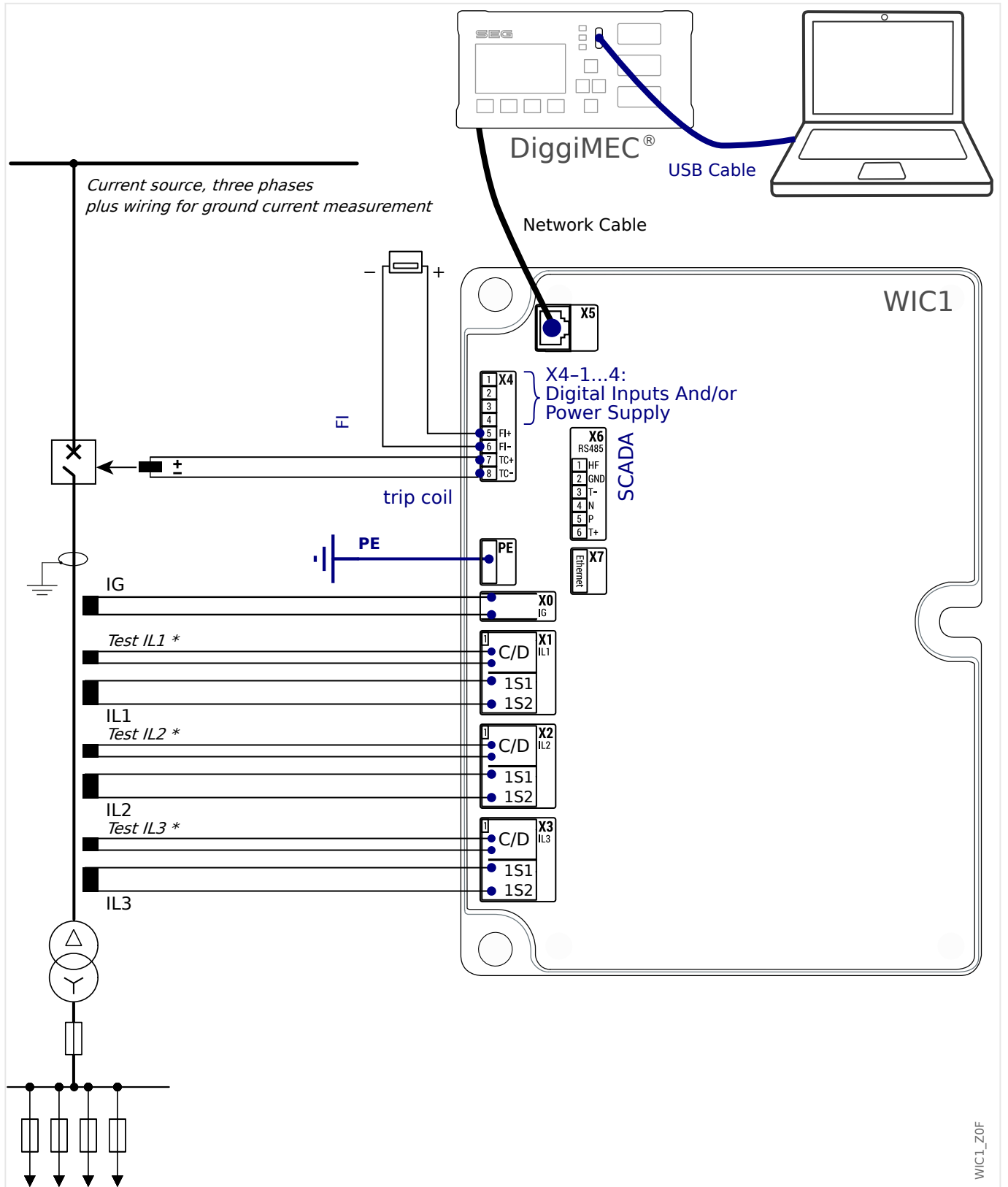

Fig. 2: Basic wiring concept.

(\*) The test windings "C-D" are only needed for the secondary tests during commissioning, see ["8.1.4 Checks During Commissioning"](#).

WIC1\_Z0F

**NOTICE!**

The assignment of the contacts X4-1 ... X4-4 depends on the device variant. The separate document "WIC1 Wiring Diagrams" lists the exact contact assignments for each available typecode / order variant. It is recommended to look up this assignment for the WIC1 that is about to be wired.



If the use of 1 A (or 5 A) standard CTs is mandatory (for technical or historical reasons) it is possible to connect [special adapter CTs](#) between the 1 A CTs and the WIC1. See [↪ "3.3.3 Adapter CTs for 1 A / 5 A"](#) for information.

## 2.2 Operating Concept for the WIC1

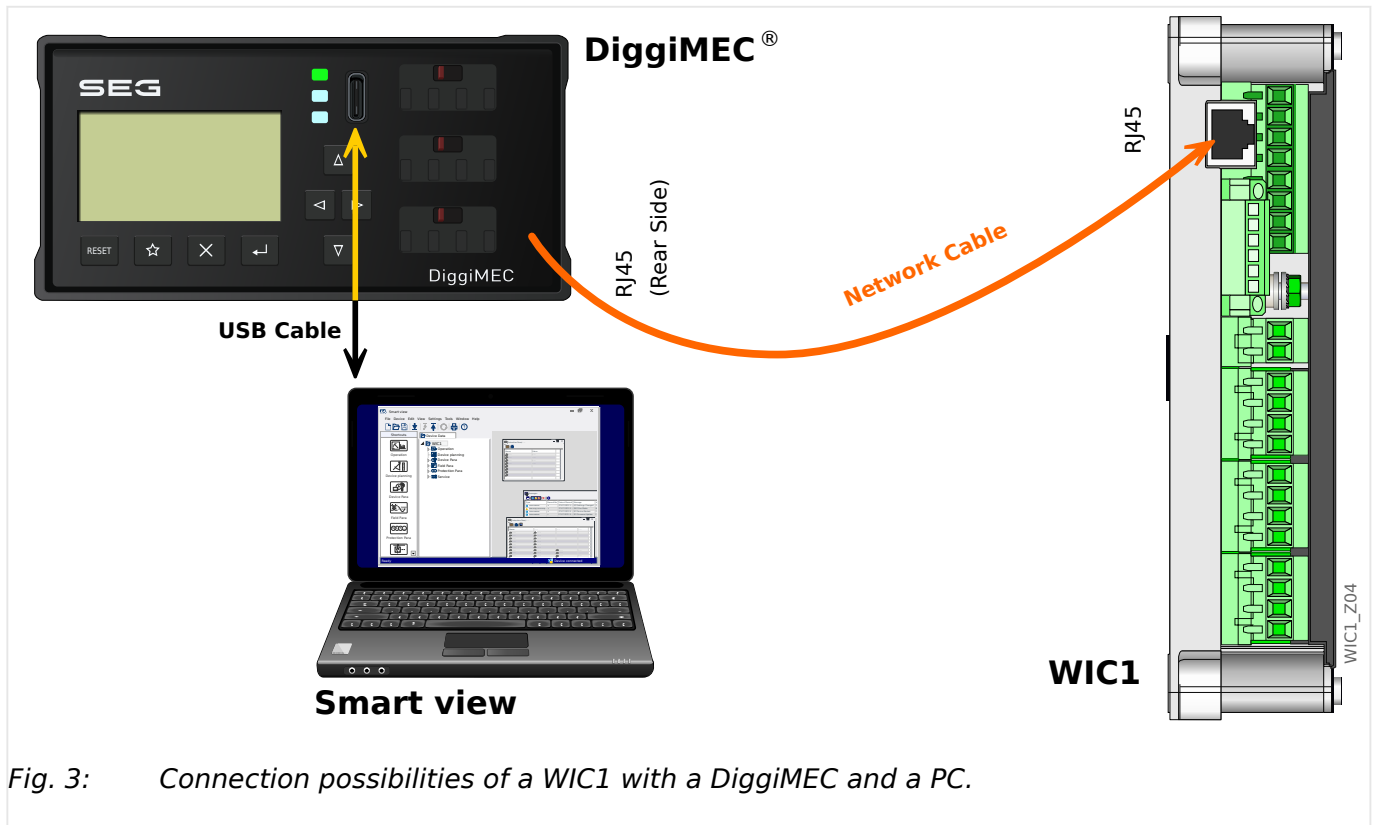

Fig. 3: Connection possibilities of a WIC1 with a DiggiMEC and a PC.

As a combination of a compact protection relay and related core-type transformer, the WIC1 has been developed especially for compact MV switchboards with circuit breakers.

The intuitive operating concept with plausibility checks and easy commissioning functions allows a safe and time-optimized maintenance and commissioning. The **WIC1** can be (optionally) connected to the interface device **DiggiMEC**<sup>®</sup>, which adds an LCD display, keys and some flag indicators with output relays.

The **DiggiMEC** can be connected to a Windows PC, so that the parameter setting and evaluation software *Smart view* can be used to configure the WIC1 and to retrieve measurement values and fault data from the WIC1. (See also [↳ “2.7.1 Smart view”](#).)

### NOTICE!



The **DiggiMEC** is always usable only with a connected **WIC1** (independent of whether there is any supply via the USB interface of the DiggiMEC).



DiggiMEC<sup>®</sup> is a registered European Union trademark. For the sake of readability, most chapters of this User Manual omit the “<sup>®</sup>” designation. This, however, does not mean that the term “DiggiMEC” can be used without any restrictions.

## 2.3 Supply of a WIC1

If a WIC1 is being operated in a typical application it is supplied via the CTs, and this is surely the normal case after commissioning.

But for the case of completeness, we want to list all ways to supply a WIC1:

Permanent Supply:

- Supply via the phase CTs, under the condition that these have been selected correctly ([↪ “3.3.2 Selection of a WIC1-Compatible Current Transformer”](#)) and there is sufficient phase current flowing ([↪ “10.1.6 Power Supply”](#)).
- Only WIC1-4: Supply via an external auxiliary voltage ([↪ “10.1.6 Power Supply”](#)). This is optional and independent of the supply via CTs. It enables the WIC1-4 to stay in operation after a protection trip, and only this allows for using some special functions, such as the Circuit Breaker Failure protection ([↪ “5.13 CBF – Circuit Breaker Failure \[50BF, 62BF\]”](#)). Another example, that would be technically impossible without an additional external supply, is connecting an external output relay to be used as a self-supervision contact ([↪ “3.8.1 Self-Supervision Contact for the WIC1-4”](#)).

Temporary Supply:

- Supply via the USB interface of a connected DiggiMEC ([↪ Chapter 2.2](#)). This makes sense during commissioning and is independent of the supply via CTs (and of the external WIC1-4 supply).
  - Connecting a PC to the USB interface: This also enables the use of *Smart view*, see [↪ Chapter 2.2](#).
  - Connecting a powerbank to the USB interface: Whether this is possible or not depends on the type of powerbank. See [“Troubleshooting: Supply via Powerbank is not possible”](#).

Note, however, that the USB supply is not designed as a permanent supply (but only for a DiggiMEC / Smart view connection). Furthermore, a supply **only** via USB is not sufficient to enable a trip pulse ([“Troubleshooting: System-LED is Off”](#)), and therefore also the green System/Ready LED stays off ([↪ “The »System« LED\(s\) - “Ready”, “Error””](#)).

Moreover, you should note that a DiggiMEC without a connected WIC1 is never operational, even with USB supply.

- For a short time (let us say: for a typical signal duration), the voltage of an external signal, that is applied at the Digital Input of the WIC1, can also boot up the WIC1, and this might under some circumstances be required for an external trip ([↪ “5.12 ExP – External Protection”](#)).

**WARNING!**



Except for this special case of a short time signal (for an external trip), it is not permitted to feed any long-term or continuous voltage into the Digital Inputs.

In other words, it is strongly discouraged to try to supply the WIC1 (for a considerable time) via the Digital Inputs.

If this is ignored the Digital Input can be overloaded, and this can lead to a permanent damage of the WIC1.



## 2.4 WIC1 Protection Features

### 2.4.1 Functional Overview

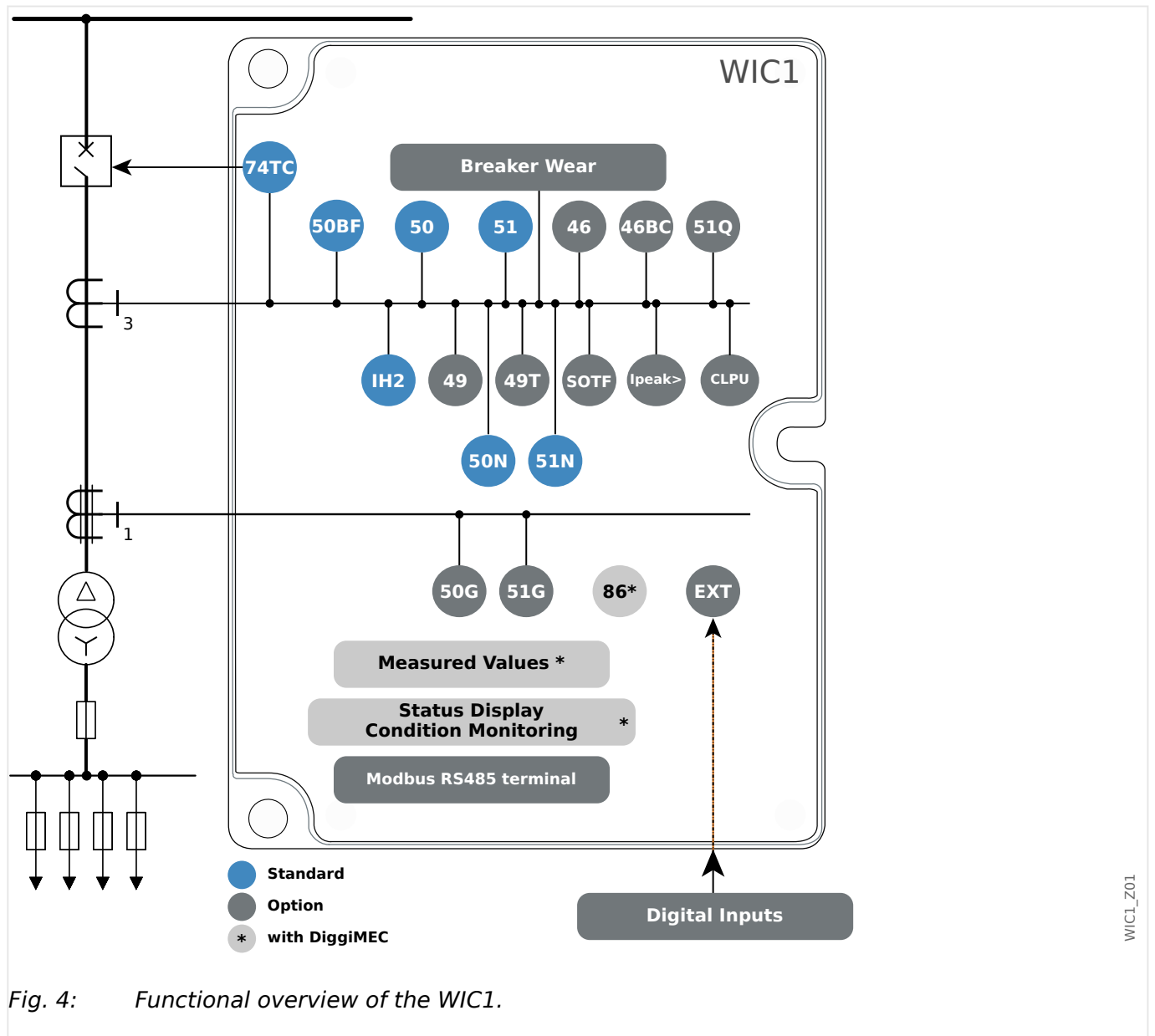

Fig. 4: Functional overview of the WIC1.

## 2.4.2 Device Features

Features	WIC1
<b>Primary Application Type</b>	
Self-/CT-Powered. (Device variant <a href="#">WIC1-4</a> with optional auxiliary power supply)	✓
<b>Mounting Type</b>	
Housing suitable for mounting plate	✓

Inputs and Outputs	WIC1
<b>Inputs and Outputs of <a href="#">WIC1-1 ... WIC1-3</a></b>	
Current transformer inputs	3 (phase currents), 1 ground current (option)
Binary inputs	0 ... 1 (option – only 115 VAC or 230 VAC)
Pulse Output	1 ... 2 (option)
<b>Inputs and Outputs of <a href="#">WIC1-4</a></b>	
Current transformer inputs	4
Binary inputs	0 ... 2 (option)
Pulse Output	1 ... 2 (option)

Protection and Supervision Features	ANSI / IEEE C37.2	WIC1
<b>Protection</b>		
Remark: Every protection function can also be configured to operate without tripping, i. e. as a supervision function.		
Time overcurrent protection	50 / 51	I>, I>>, I>>>
Inrush stabilisation (2nd harmonic)	IH2	IH2
Calculated ground (earth) fault protection	50N / 51N	IG>, IG>>
Measured ground (earth) fault protection	50G / 51G	IG>, IG>> <ul style="list-style-type: none"> <li>• <a href="#">WIC1-1 ... WIC1-3: option</a></li> <li>• <a href="#">WIC1-4: ✓</a></li> </ul>
Ultra-fast Peak Overcurrent protection		Ipeak> (option)
Unbalanced Load protection	46	I2/I1> (option)
Negative-Sequence Current Protection	51Q	I2> (option)
Thermal Overload protection	49	ThR (option)
Switch on to Fault (SOTF)		SOTF (option)
Cold Load Pickup (CLPU)		CLPU ( <a href="#">WIC1-4</a> )
External Trip		ExP (option)
<b>Supervision</b>		
Circuit breaker failure	50BF 62BF ( <a href="#">WIC1-4</a> only)	CBF

<b>Protection and Supervision Features</b>	<b>ANSI / IEEE C37.2</b>	<b>WIC1</b>
Breaker Wear		Breaker Wear
<b>Condition Monitoring</b>		
Peak Current Pointer		Peak Current Ptr
Life Load		Life Load
<b>Recorders</b>		
Fault recorder (non-volatile)	DFR	✓
Self-Supervision logging (messages about device-internal events - non-volatile)		✓
<b>SCADA Communication</b>		
<b>(only WIC1-4)</b>		
Modbus RTU	(only WIC1-4xxxxxxxB)	✓

## 2.5 Comments on the Manual

This manual explains in general the tasks of device planning, parameter setting, installation, commissioning, operation and maintenance of the WI Line devices.

The manual serves as working basis for:

- Engineers in the protection field,
- commissioning engineers,
- people dealing with setting, testing and maintenance of protection and control devices,
- as well as trained personnel for electrical installations and power stations.

All functions concerning the type code will be defined. Should there be a description of any functions, parameters or inputs/outputs which do not apply to the device in use, please ignore that information.

All details and references are explained to the best of our knowledge and are based on our experience and observations.

This manual describes the (optionally) full featured versions of the devices.

All technical information and data included in this manual reflect their state at the time this document was issued. We reserve the right to carry out technical modifications in line with further development without changing this manual and without previous notice. Hence no claim can be brought based on the information and descriptions this manual includes.

Text, graphic and formulae do not always apply to the actual delivery scope. The drawings and graphics are not true to scale. We do not accept any liability for damage and operational failures caused by operating errors or disregarding the directions of this manual.

No part of this manual is allowed to be reproduced or passed on to others in any form, unless *SEG* have approved in writing.

This user manual is part of the delivery scope when purchasing the device. In case the device is passed on (sold) to a third party, the manual has to be handed over as well.

Any repair work carried out on the device requires skilled and competent personnel who need to be well aware especially of the local safety regulations and have the necessary experience for working on electronic protection devices and power installations (provided by evidence).

### ***Information Concerning Liability and Warranty***

*SEG* does not accept any liability for damage resulting from conversions or changes carried out on the device or planning (projecting) work, parameter setting or adjustment changes done by the customer.

The warranty expires after a device has been opened by others than *SEG* specialists.

Warranty and liability conditions stated in *SEG* General Terms and Conditions are not supplemented by the above-mentioned explanations.

## 2.5.1 Symbols in Function Diagrams

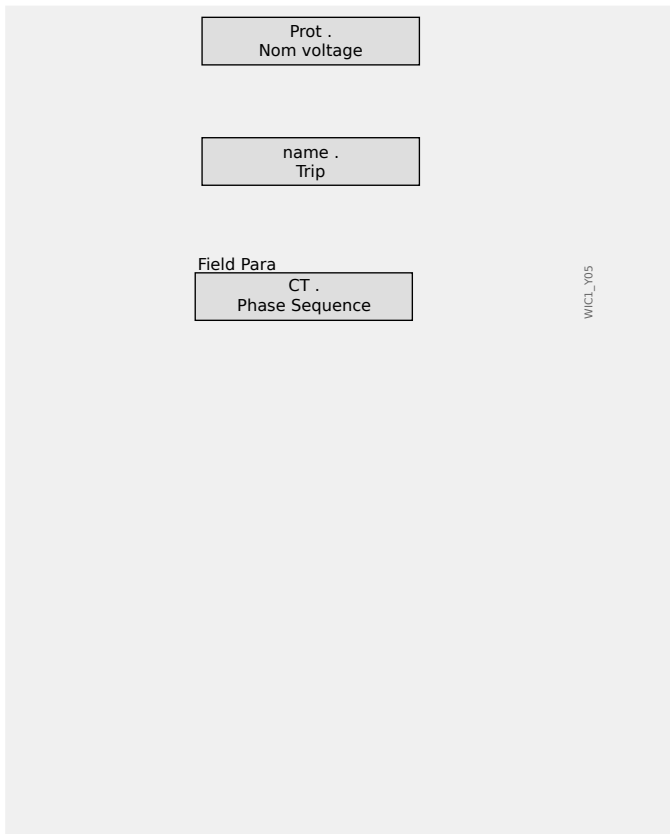

### Setting Values

The upper box in the diagram on the left is the usual symbol of a setting value in a function diagram. The setting name is specified by its module and parameter name, separated by a dot “.” one from the other.

Second example: Thanks to the high degree of modularization in WI Line protection devices, the logic depicted in some function diagrams is often valid for several modules. In these cases, only a symbolic module name, for example: “*name*”, is given. In the heading part of the diagram, the meaning of “*name*” is specified as a list of modules to which the diagram applies.

In rare cases it is necessary to also specify the menu path (or at least the top-level menu item), because it would be too inconvenient to specify this particular setting only based on module name and parameter name. In the third example, the setting is marked as a Field Parameter (i. e. to be found within menu branch [Field Para]).

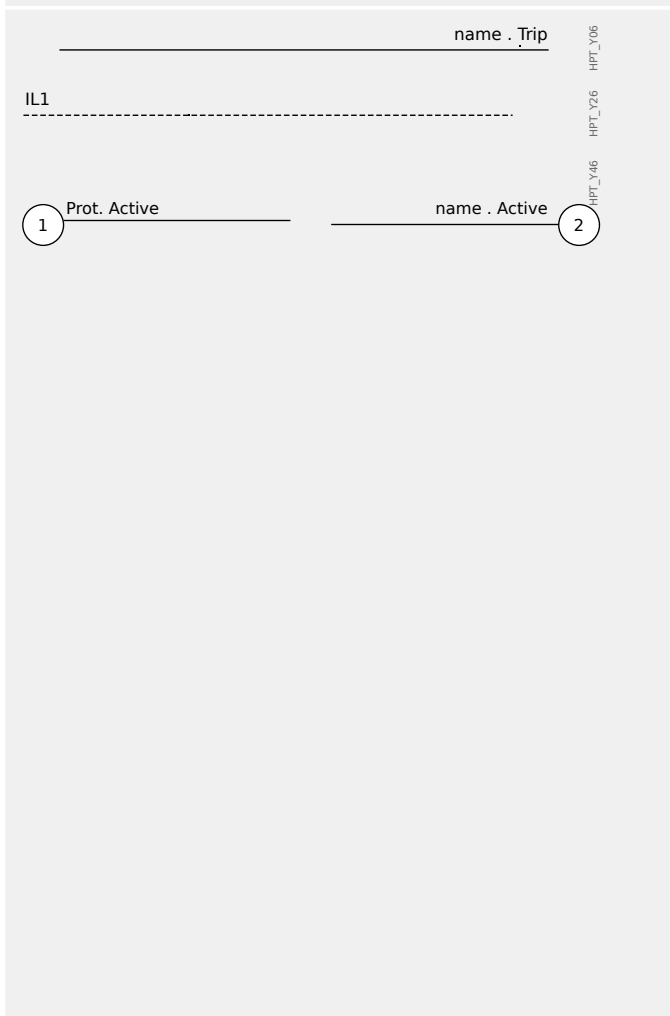

### Input and Output Signals

A binary (output) signal is shown on top.

A dashed line indicates a measured value (i. e. an analog signal).

Bottom row left: Numbered input signal; right: numbered output signal: From the technical point of view, there is no difference to “normal” (non-numbered) signals.

Some of these numbers, however, represent generic signals. For example, every protection function has a trip signal »*Trip*«, and there is always the same number used for it, independent of the particular protection function.

A numbered signal typically appears in several different diagrams, and the numbering helps to identify and locate them across the Technical Manual.

Therefore all encircled numbers appearing “on the right side” (i. e. as an output signal) of a diagram are listed as part of the Index chapter (sorted below the initial letter “*⊗*”), so that you can look up where a particular signal has been “generated”.

Wherever technically possible, these input numbers within a diagram are hyperlinks, and a click takes you to a page where this numbered signal is explained or shown as an output signal.

Another remark: All diagrams in this document show a small label, for example the bottom one: "HPT\_Y46". This is the diagram name, i. e. a unique identifier for the diagram. Of course, this is not a setting name, nor any other part of the depicted logic. All function diagrams have an identifier with the characters "\_Y".)

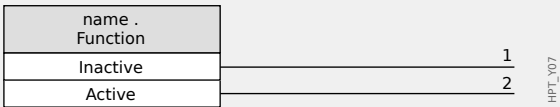

If the setting value of parameter »name . Function« is set to "Inactive", then output 1 is active and output 2 is inactive.

If the setting value of parameter »name . Function« is set to "Active", then output 1 is inactive and output 2 is active.

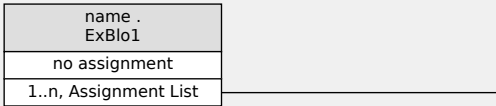

The setting value of parameter »name . ExBlo1« is not a choice from a simple, fixed selection list, but it is another parameter (usually a binary output signal) that is assigned from a parameter list.

This means that the setting parameter assumes the value of the assigned parameter. In case of a binary output signal, for example, it means that the parameter »name . ExBlo1« is active whenever the assigned output signal is active.

If no signal has been assigned then the output is always inactive (and only the "no assignment" box, which is not connected in this example, would be active).

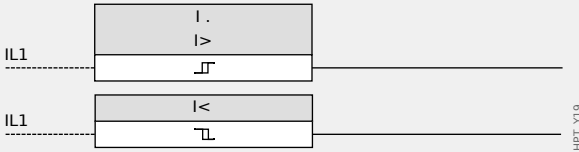

Two types of comparators ("Schmitt triggers"):

Top row: If the analog input value (here: the phase current IL1) is greater than the specified threshold (here: the setting value of the parameter »I . I >«) then the output becomes active.

Bottom row: This type has the opposite functionality: If the analog value IL1 is **below** the threshold (here: the setting value of the parameter I <«) then the output becomes active.

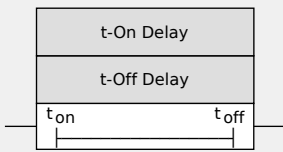

Timer stage: If the input becomes active, then the output becomes active after the time  $t_{on}$  (setting value of »t-On Delay«) has elapsed (switch-on delay).

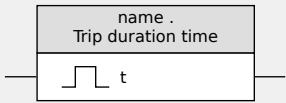
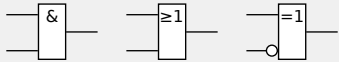
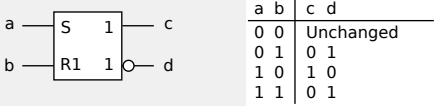
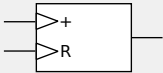
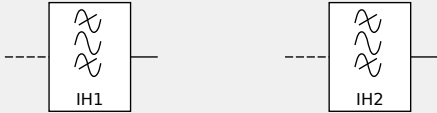
	<p>If the input becomes inactive again, then the output signal becomes inactive after the other specified duration has elapsed (switch-off delay <math>t_{off}</math>, setting value of »t-Off Delay«).</p>																				
	<p>Hold time: This is a pulse which is triggered by the input (and in this case, the pulse duration is settable via parameter).</p>																				
	<p>The usual set of logic operators: AND, OR, eXclusive OR (from left to right). The second input of the XOR operator is negated.</p>																				
 <table border="1" data-bbox="435 685 627 790"> <thead> <tr> <th>a</th> <th>b</th> <th>c</th> <th>d</th> </tr> </thead> <tbody> <tr> <td>0</td> <td>0</td> <td colspan="2">Unchanged</td> </tr> <tr> <td>0</td> <td>1</td> <td>0</td> <td>1</td> </tr> <tr> <td>1</td> <td>0</td> <td>1</td> <td>0</td> </tr> <tr> <td>1</td> <td>1</td> <td>0</td> <td>1</td> </tr> </tbody> </table>	a	b	c	d	0	0	Unchanged		0	1	0	1	1	0	1	0	1	1	0	1	<p>RS flip-flop with reset priority.</p>
a	b	c	d																		
0	0	Unchanged																			
0	1	0	1																		
1	0	1	0																		
1	1	0	1																		
	<p>Edge-triggered counter.</p>																				
	<p>Band-pass filter (left: IH1, right: IH2).</p>																				

## 2.6 Information About the Device

### **Scope of Delivery**

The delivery scope includes:

- **(1)** — The transportation box
- **(2)** — The protective device
- **(3)** — The test report

Please check the consignment for completeness on arrival (delivery note).

Please ascertain whether the type plate, connection diagram, type code and description of the device are matching your order.

If you have any doubts please contact our Service Department (contact address to be found on the reverse of the manual).

### **Download Area**

All technical documentation (User Manual, Reference Manual, etc.) and setup files for the Windows applications (Smart view, DataVisualizer) can be downloaded directly (and without any costs) from <https://docs.SEGelectronics.de/wic1>.

- <https://docs.SEGelectronics.de/wic1> — This web address is also available as a QR code directly on the housing of the device.
- [https://docs.segelectronics.de/smart\\_view](https://docs.segelectronics.de/smart_view) — Setup of the Windows applications incl. documentation.

### **Product DVD**

A product DVD with all technical documentation (User Manual, Reference Manual, etc.) and setup files for the Windows applications (Smart view, DataVisualizer) can be ordered separately. This way users who are not connected to the internet can get all files that are required or useful during commissioning.

### **Storage**

The devices must not be stored outdoors. The storing facilities have to be sufficiently ventilated and must be dry (see [↳ “10.1 Technical Data - WIC1”](#)).

### **Waste Disposal**

In general, appropriate local guidelines and regulations must be followed when disposing of electrical devices.

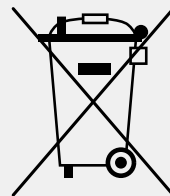



## 2.6.1 Order Form of the Device

There are four different main variants of the WIC1 available, and these can have different additional order options:

- WIC1-**1**...: CT-Powered Protection Device without any switches, all settings are made with the DiggiMEC user interface. See [↳ “2.6.1.1 Order Form of the CT-Powered Device Types”](#).
- WIC1-**2**...: CT-Powered Protection Device with DIP switches, all settings can be made either with these DIP switches, or - more exactly - with the DiggiMEC user interface. See [↳ “2.6.1.1 Order Form of the CT-Powered Device Types”](#).
- WIC1-**3**...: CT-Powered Protection Device with HEX switches, all settings can be made either with these HEX switches, or - more exactly - with the DiggiMEC user interface. See [↳ “2.6.1.1 Order Form of the CT-Powered Device Types”](#).
- WIC1-**4**...: Dual-Powered Protection Device without any switches, all settings are made with the DiggiMEC user interface. Various additional features, such as SCADA communication, are optionally available. See [↳ “2.6.1.2 Order Form of the Dual-Powered WIC1-4”](#).

### **DiggiMEC / Smart view**

The DiggiMEC is a small device that has to be ordered separately. It fits into a standard door cutout of 92 mm × 45 mm (DIN IEC 61554) and can be connected to the WIC1 (via a standard network cable with RJ45 plugs). It then adds an HMI, i. e. a graphical display and hardware keys, to the WIC1. Moreover, it offers 1 or 3 bi-stable output relays that are mechanically combined with flag indicators.

See [↳ “2.6.1.6 Order Form of the DiggiMEC”](#).

- DiggiMEC-A: 1 bi-stable relay / flag indicator
- DiggiMEC-B: 3 bi-stable relays / flag indicators

If the DiggiMEC user interface is connected to the WIC1, it is also possible to connect a PC to the USB interface of the DiggiMEC.

The PC can then execute the parameterizing and analyzing software Smart view and enables the user to make all settings via this connection, or to save settings to a file on the PC, or retrieve measured values or trip event data.

**2.6.1.1 Order Form of the CT-Powered Device Types**

<b>CT Powered Time Overcurrent and Earth Current Relay</b>									
<b>WIC1</b>	-	#	#	#	#	#	#	#	#
<b>Mounting form</b>	↓								
Parameter setting via DiggiMEC / Smart view	<b>1</b>								
Parameter setting via DIP switches, DiggiMEC or Smart view	<b>2</b>								
Parameter setting via HEX switches, DiggiMEC or Smart view	<b>3</b>								
<b>CT Type</b>	↓								
WIC1 CTs	<b>S</b>								
<b>Ground (Earth) current protection</b>	↓								
Calculated ground (earth) current	<b>N</b>								
With ground (earth) current measuring inputs, rated ground/earth current: 1 A (**)	<b>G</b>								
<b>Nominal frequency</b>	↓								
50 Hz (***) (only WIC1-2, WIC1-3)	<b>5</b>								
60 Hz (***) (only WIC1-2, WIC1-3)	<b>6</b>								
50 Hz / 60 Hz (***) (WIC1-1 only)	<b>0</b>								
<b>Outputs</b>	↓								
The Trip Command is assigned to the “TC” (Trip Coil pulse) output. (This assignment is pre-defined and fixed.)	<b>N</b>								
The Trip Command is assigned to both the “TC” (Trip Coil pulse) output and to the “FI” (Flag Indicator) output.	<b>F</b>								
The “FI” (Flag Indicator) output can be set to any output signal. The Trip Command is fixed and assigned to the “TC” (Trip Coil pulse) output.	<b>C</b>								
<b>Inputs</b>	↓								
No digital inputs	<b>N</b>								
External trip input (115 Vac or 230 Vac)	<b>F</b>								
1 assignable Digital Input (115 Vac or 230 Vac)	<b>C</b>								
<b>Backup protection</b>	↓								
Backup protection operates directly (****)	<b>1</b>								
Trip at 20·In,max	<b>2</b>								
<b>Protection Packages</b>	↓								
ANSI 50, 50G/N, 51, 51G/N, Inrush Blocking, 50BF, 74TC	<b>S</b>								
Package “S” + ANSI 46, 49, 51Q, Breaker Wear, Condition Monitoring (= Life Load, Drag Indicator)	<b>A</b>								
Package “A” + SOTF, external protection <sup>(DI)</sup> , ultra-fast overcurrent protection	<b>P</b>								
<b>Communication</b>	↓								
Without communication protocol	<b>A</b>								

### NOTICE!



(\*\*) Via DiggiMEC or Smart view (but not via DIP/HEX switches), it is possible to configure the device for either calculated or measured ground (earth) current.



(\*\*\*) Via DiggiMEC or Smart view (but not via DIP/HEX switches), it is possible to configure the device for either 50 Hz or 60 Hz nominal frequency.

(\*\*\*\*) Trip of the backup protection as soon as sufficient electrical energy for a trip impulse has been collected.

(DI) External protection is usable only with a Digital Input.

### 2.6.1.2 Order Form of the Dual-Powered WIC1-4

Dual-Powered Time Overcurrent and Earth Current Relay									
<b>WIC1</b>	-	#	#	#	#	#	#	#	#
<b>Mounting form</b>	↓								
Dual-Powered Powered Relay, parameter setting via DiggiMEC	4								
<b>CT Type</b>	↓								
WIC1 CTs	S								
<b>Earth current protection</b>	↓								
With ground (earth) current measuring inputs, rated ground/earth current: 1 A (**4)	G								
<b>Nominal frequency</b>	↓								
50 Hz / 60 Hz (**4)	0								
<b>Outputs</b>	↓								
The Trip Command is assigned to the “TC” (Trip Coil pulse) output. (This assignment is pre-defined and fixed.)	N								
The Trip Command is assigned to both the “TC” (Trip Coil pulse) output and to the “FI” (Flag Indicator) output.	F								
The Trip Command is fixed and assigned to the “TC” (Trip Coil pulse) output. The “Out” output can be configured.	C								
<b>Inputs</b>	↓								
No digital inputs	M								
External trip input, external reset input	G								
2 assignable Digital Inputs	D								
<b>Backup protection</b>	↓								
Backup protection operates directly (****)	1								
Trip at 20·In,max	2								
<b>Protection Packages</b>	↓								
ANSI 50, 50G/N, 51, 51G/N, Inrush Blocking, 50BF, 74TC	S								
Package “S” + ANSI 46, 49, 51Q, Breaker Wear, Condition Monitoring (= Life Load, Drag Indicator)	A								
Package “A” + SOTF, CLPU, external protection <sup>(DI)</sup> , ultra-fast overcurrent protection	P								
<b>Communication</b>	↓								
Without communication protocol	A								
Modbus RTU   RS485 / terminals (#)	B								

## NOTICE!



(\*\*4) Via DiggiMEC or Smart view, it is possible to configure the device for either calculated or measured ground (earth) current.



(\*\*\*4) Via DiggiMEC or Smart view, it is possible to configure the device for either 50 Hz or 60 Hz nominal frequency.

(\*\*\*\*) Trip of the backup protection as soon as sufficient electrical energy for a trip impulse has been collected.

(#) More SCADA protocols are planned for the next Releases.

(DI) External protection is usable only with at least one Digital Input.

### 2.6.1.3 Order Form of the WIC1-Compatible Current Transformers

#### **WIC1 CTs**

Officially tested and recommended CTs for the WIC1 exist in two independent (electrically equivalent and interchangeable) construction types.

<b>Current Transformer (1 Piece)</b>			
<b>Short name + Primary Current Range</b>	<b>Accuracy Class</b>	<b>Order Code Construction Type 1</b>	<b>Order Code Construction Type 2 (*)</b>
WE2 [16 - 56 A]	5P80	WIC1-CT2-5P	WIC1-WE2AS1
W2 [16 - 56 A]	10P80	WIC1-CT2-10P	WIC1-W2AS1
W3 [32 - 112 A]	5P80	WIC1-CT3	WIC1-W3AS1
W4 [64 - 224 A]	5P80	WIC1-CT4	WIC1-W4AS1
W5 [128 - 448 A]	5P80	WIC1-CT5	WIC1-W5AS1
W6 [256 - 896 A]	5P80	-	WIC1-W6AS1

For further technical data of these CTs see [↳ “3.3.2.1 Current Ranges of the WIC1-CTs”](#).

#### **Adapter CTs for 1 A or 5 A**

If the use of 1 A (or 5 A) standard CTs is mandatory (for technical or historical reasons) it is possible to connect special adapter CTs between the standard CTs and the WIC1. See [↳ “3.3.3 Adapter CTs for 1 A / 5 A”](#) for information, [↳ “Adapter CTs for 1 A / 5 A”](#) for dimension drawings and [↳ “10.4.3 Technical Data - Adapter CTs for 1 A, 5 A”](#) for Technical data.

<b>Adapter CT (for 3 phases, combined in 1 housing)</b>	
<b>Short name + Rated Current</b>	<b>Order Code</b>
Adapter CT 1 A	WIC1-CT-1A/3P
Adapter CT 5 A	WIC1-CT-5A/3P

**2.6.1.4 Order Form WI1SZ4**

<b>Flag Indicator</b>	<b>Article Number</b>
Small type, front 34 × 23 mm	<b>WI1SZ4</b>

**2.6.1.5 Order Form WI1SZ5**

<b>Flag Indicator</b>	<b>Article Number</b>
Small type, front 34 × 23 mm, with bi-stable signal contacts 230 V AC, 3 A	<b>WI1SZ5</b>

### 2.6.1.6 Order Form of the DiggiMEC

<b>Nano-HMI with Flag Indicators</b>	
<b>DiggiMEC</b>	<b>-#</b>
<b>Type</b>	↓
Door mounting, 1 bi-stable relay / flag indicator	<b>-A</b>
Door mounting, 3 bi-stable relays / flag indicators	<b>-B</b>



## 2.7 Settings – Operation

Pursuant to the intended maintenance-free design there is no user interface with display.

For the variants **WIC1-1** and **WIC1-4**, all settings can only be done via the communication interface, by means of the DiggiMEC interface device.

For the variants **WIC1-2**, all settings can be made either with DIP switches, or – more exactly – with the DiggiMEC user interface.

For the variants **WIC1-3**, all settings can be made either with HEX switches, or – more exactly – with the DiggiMEC user interface.

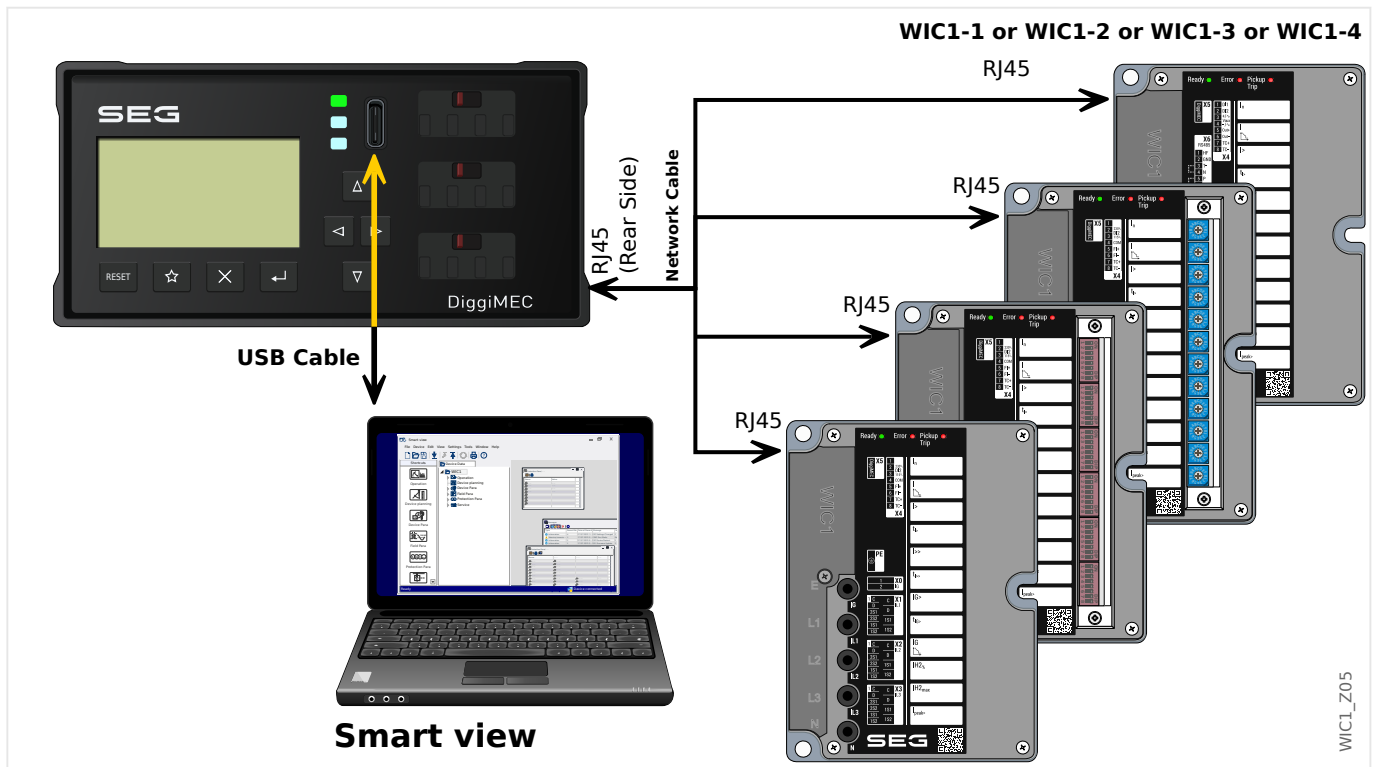

### Validity of the DIP-/HEX-Switches

Many parameters and protection functions are not accessible by the DIP switches of the WIC1-2 or HEX switches of the WIC1-3. This is a natural result of the limited number of switches.

All these settings have appropriate default values, and inaccessible protection functions are deactivated. This way there is a well-defined functional range for the WIC1, so that it can be used only based on DIP/HEX settings, and vice versa, the DOP/HEX switches reflect the functionality in use sufficiently well.

Using the DiggiMEC / Smart view, however, the whole implemented functional range with all settings can be accessed. But if this “*software-settings*” operation mode is active, all DIP/HEX settings are ignored.

- This parameter defines for the WIC1-2 or WIC1-3 which settings shall be used:
- [Device planning / WIC1 + DiggiMEC] »Prot . Settings valid« =

Options:

- “Switches” — DIP/HEX settings shall be used.

- “Software” — DiggiMEC/Smart view settings shall be used.

### NOTICE!



- In operating mode “Switches”, all the switches are permanently monitored, but with a particular delay of approx. 10 seconds. This means: Only after no further switching has been done after 10 s, all (DIP/HEX) switch positions are evaluated. If a new configuration results from the switch positions then the WIC1 performs a warm restart, so that it can properly resume operation based on the new settings.
- It is recommended to fix the acrylic glass cover after all DIP/HEX switch settings have been done. The cover offers some simple protection against unintended or unauthorized re-configuration.
- Due to technical (device-internal) constraints it is **not** possible to set the parameter »Prot . Settings valid« back from to “Software” to the “Switches” operation mode! If it is required to re-enable DIP/HEX switch settings the only way to do this is to set the WIC1 back to factory defaults. This will then make the WIC1 re-read all switch positions, and all other settings (that are inaccessible by the DIP/HEX switches) get set back to their respective default values; see also [↩](#) “2.13 Reset to Factory Defaults”.
- Settings changes that are made via DIP/HEX switches are not automatically transferred to a connected Smart view. This means that Smart view still shows the previous setting until pressing the key »F2« at the PC (or Smart view menu item “Receive Data from Device”) makes Smart view retrieve all data again. Note that the “Auto Refresh” button / menu item is only for keeping the [Operation] menu branch of the device (i. e. measured values, states, etc.) updated. The “Auto Refresh” is not for settings.

A connected DiggiMEC, however, realizes and displays DIP/HEX switch changes as soon as they become effective.

### NOTICE!



An offline configuration (i. e. prepare parameter settings in advance via *Smart view* and without a connected WIC1) is possible, even for a WIC1 variant with DIP/HEX switches. But it must be kept in mind that after selecting the typecode, *Smart view* always starts with the factory defaults for all settings. But this means that the initial setting for »Prot . Settings valid« is “Switches”, so that *Smart view* seems to have all (other) settings locked.

The first step for creating an offline configuration must therefore always be to set »Prot . Settings valid« = “Software”. Only after this will *Smart view* unlock all settings.

## 2.7.1 Smart view

*Smart view* is a parameter setting and evaluation software. It has a Technical Manual of its own.

- Menu-controlled parameter setting incl. validity checks
- Offline configuration
- Reading and evaluating of measuring values
- Setting into operation assistance
- Display of the device status
- Fault analysis via fault recorder

For a complete WIC1 configuration it is recommended to use the *Smart view* setting and evaluation software, because it is too cumbersome to make a large amount of settings using the DiggiMEC panel.

For *Smart view*, a PC with Windows (7, 8.x or later, upgraded to the latest officially available status) operating system is required.

Moreover, a connecting cable of type USB-C is required for a direct connection of the DiggiMEC with the PC, and a network cable (also known as “Ethernet cable”) for connecting DiggiMEC and WIC1. See also [↳ Fig. 2](#), [↳ Fig. 3](#).

Further informationen can be found in [↳ “3.10.1.6 Operation via Smart view”](#) and of course in the *Smart view* documentation.

## 2.8 Device Planning

“Device Planning” means to change the functional range to a degree that suits the protection task to be fulfilled. There is a top-level menu item [Device planning] that is dedicated to this, and it makes essentially the following types of settings available:

- For WIC1-2 und WIC1-3: Select which settings shall be used, the switch settings or the DiggiMEC / Smart view settings.
- Activation of the functions that are needed for the application, and deactivation of the other ones.
- For the activated protection functions: Select whether these shall trip the circuit breaker or issue a warning message. See [↳ “Definition \(“Alarm ↔ Trip”\) of a Protection Function”](#) for information on this.

### **Switch Settings or Software Settings**

Device variants WIC1-2 and WIC1-3 are set via DIP or HEX switches, respectively. But independent of these switch settings it is still possible to make settings via DiggiMEC / Smart view.

To prevent a potential conflict between what is set via the switches, and what is set via DiggiMEC / Smart view, there is the setting [Device planning] »Settings valid«. It selects whether the WIC1 shall actually use the switch settings or the DiggiMEC / Smart view settings.

The factory default of »Settings valid« is “Switches”, so that it is possible to configure these devices without a DiggiMEC.

Note that not all settings of the WIC1-2 / WIC1-3 can be “reached” via DIP / HEX switches. This has the effect that for a configuration via switches (»Settings valid« = “Switches”), all settings that are not assigned to any DIP / HEX switch are always set to their respective factory defaults. See also [↳ “Validity of the DIP-/HEX-Switches”](#).

### **Activation of Functions**

In general, it is always important to activate only those functions that are needed, and deactivate the others. (Of course, this is particularly essential when settings are made via DiggiMEC / Smart view. For devices with DIP or HEX switches, there is already a factory default for this.)

The menu [Device planning] collects a setting parameter named »Mode« for each function, which can be set to “-” or to “use”.

If the user, for example, deactivates the inrush protection function, all menu branches related to this function disappear from the menu tree. All corresponding events, signals, etc., are deactivated as well. This simplifies the menu tree.

**WARNING!**

It **MUST** be taken into account that Device Planning changes the functionality of the device.

If the user deactivates a protection function, the device will no longer trip according to the criteria related to this protection function.

The manufacturer does not accept liability for any personal or material damage as a result of incorrect planning.

Contact your SEG Customer Service representative for more information. SEG also offers configuration support as a service.

**WARNING!**

Beware of the inadvertent deactivating of protective functions/modules, because all the settings of a deactivated module get lost (i. e. are set back to their respective default values)!

This means: If the user is activating any of these modules again at some later time, all parameters of the re-activated modules need to be reconfigured.

## 2.9 Modules, Settings, Signals and Values

The WIC1 is a digital protection device that holds various data in its internal memory. Some data is meant to be changed by the user to adapt the functionality to the respective application, other data types are set by the device during run-time and are therefore read-only from the user's perspective.

All settings, device planning and checking the state of signals at run-time can be done:

- Directly at a DiggiMEC that is connected to the WIC1; or
- using the *Smart view* software application.

### Modules

The firmware of the WIC1 can be thought of being sub-divided in several independent function blocks. Throughout our Technical Documentation, we are talking of “modules” (or sometimes of “functions”). Every protection function, for example, is a module of its own. For WI Line devices, this is a fundamental concept. For example, there is a general protection module (named »Prot«, see [↪ “5.1 »Prot« - General Protection Module”](#)) that interacts with all specific protection modules.



It is important to know that every parameter and every signal and value is always part of exactly one module (even if the module name might not be displayed on the DiggiMEC display for the sake of simplicity).

Modules can interact with each other, either because this is a fixed implemented part of the firmware, or if the user has assigned some signal of a module to a parameter (that becomes a module input this way). An example for a fixed implemented interaction is that the trip signal of any protection module always triggers the trip signal of the general »Prot« module.

Some modules exist in several (identical) instances, which can be activated and configured independently. These can be used to have several protection stages. However, there is one fundamental difference to the WIC1: The functionality of all instances (of a particular module) is always identical (except for the differences that are due to different setting values).

There is the following naming convention: If several instances of a module »Module« exist, then these are named »Module[1]«, »Module[2]«, ... (or, as a short form for descriptions: »Module[x]«).

### Types of Settings, Signals and Values

Settings (also called parameters)

- Parameters are data that can be modified by the user, to adapt the functionality of the respective application.

*Smart view* users can save all settings to a file. This is a file with a filename of the form \*.WiPara. It can be (re-)loaded at any later time, and the setting values contained therein can be transferred to some (other) WIC1 protection device. (For details see the *Smart view* manual.)

(Remark: There are a few exceptions, where a particular setting is always stored within the device and never saved to a \*.WiPara file. This is the case if it is not desirable to directly transfer the setting value from one device to another.)

There are several types of parameters, depending on the type of data they can hold. For the user, it is not necessary to know details, but it can be good to know

that there are numerical parameters (e. g. overcurrent thresholds) and parameters which hold one option out of a selection list. These select options can either be fixed values, or they can be a signal (so that during run-time, the actual parameter value equals the state of the assigned signal).

- Some parameter properties depend on the value of particular other parameters. For example, the “device planning” parameters (in the [Device planning] menu, see [↪ “2.8 Device Planning”](#)) do not only activate or deactivate protection functions but also control the visibility of their related parameters.

Some parameters depend on others not only with respect to visibility, but also default values and/or available value ranges.

#### Direct Commands

- **Direct Commands** are part of the “menu tree”, just like a setting parameter, but they are meant to be executed immediately. Therefore Direct Commands are **NOT** part of a \*.WiPara parameter file.

#### Signals

- *Signals* are run-time states, i. e. depend on the result of a protection function or on the state of a Digital Input.

*Signals* are part of the “menu tree”. They can all be found in the menu path [Operation / Status Display].

- Some *Signals* are assessments of the state of the grid and the equipment.
- Some *Signals* represent decisions that are taken by the device (e. g. a trip) based on the parameter settings.
- Many signals can be *assigned* to particular parameters. This means the function of this parameter depends on the run-time state of the signal. For example, a signal can be assigned to the 2<sup>nd</sup> or 3<sup>rd</sup> DiggiMEC LED, so that the LED is lit as soon as the assigned signal becomes “True”. (See also [↪ “3.9.1.2 LED Configuration \(DiggiMEC\)”](#).)

#### Input States (for a module input)

- Input States are special signals and are part of the “menu tree”. For every parameter to which a signal can be assigned, there is a related Input State. At run-time, the Input State reflects the current state of the assigned signal. This way the dependencies in the behavior of a protection function can be traced.

There is the following naming convention: If a parameter to which a signal can be assigned is named »Name«, then the related Input State has the name »Name-I«.

#### Counters, Values

- *Values* are more or less volatile data that are constantly kept up to date during run-time.
- The most common (and most important) type of Values is the set of *Measured Values* (e. g. the current values); we are going to use the term *Measured Values* also for values that are derived from measured values by calculation, e. g. the ground (earth) current value can be calculated from the phase currents). Of course, the set of available *Measured Values* depends on the capabilities of the particular WIC1 variant.

## 2.10 Measuring Values

### **Read out Measured Values**

In menu [Operation / Measured Values], both measured and calculated values can be viewed. The set of available measured values depends on the WIC1 variant.

### **Display Options**

The user can define how measured values are to be displayed within the DiggIMEC HMI and *Smart view*:

- Current values are displayed relative to the nominal current  $I_n$ , or:
- Current values are displayed as primary values in A.

Of course, primary values can be displayed only if the connected CT type has been correctly configured. Besides, there are further, variant-specific aspects, because the related parameters cannot be reached via DIP/HEX switches.

### **Settings via Software**

WIC1-1, WIC1-4, or WIC1-2, WIC1-3 with the setting »Prot . Settings valid« = “Software”:

The display options, CT type and nominal current (»*In,relative*« or »*CT pri*«) are set via ordinary [setting parameters](#) within the menu branch [Field Para / CT].

- The CT type is selected at »*CT Type*«. As soon as one of the available CT types [W\(E\)2](#), ... , [W6](#) is selected, the display can be toggled at any time between relative and primary current values.

- »*Display of Meas. Values*« = “Based on *In,relative*” — Display of relative current values.

The nominal current is set at »*In,relative*« as a relative value in units of  $[I_{n,min}]$ .

- »*Display of Meas. Values*« = “Primary current values” — Display of primary current values.

The nominal current is set at »*CT pri*« as a primary current in [A].

These settings can be saved by *Smart view* in a parameter file, just like any setting parameters. (Parameter files have filenames of the form \*.WiPara.) This makes it easy to load a set of settings into several WIC1 devices.

### **Settings via DIP/HEX Switches**

WIC1-2, WIC1-3 with the setting »Prot . Settings valid« = “Switches”:

The display options and CT type are set via [Direct Commands](#) within the menu branch [Field Para / CT]. A Direct Command is always immediately transferred to the WIC1 and executed. The result is - comparable to the settings via software described above - that the display of current values changes. However, Direct Commands are **never** saved within a \*.WiPara file. Therefore it is necessary to execute them separately on each WIC1, as is the case for the DIP/HEX switches.

The nominal current »*CT . In,relative*« is set - as a relative value in units of  $[I_{n,min}]$  - via the DIP/HEX switches, see also [↳ “12.1.3 Setting of the Rated CT current  \$I\_n\$ ”](#). (By the way, this is an ordinary setting parameter, that would be saved within a \*.WiPara file.)



The CT type is set via the Direct Command »*CT Type*«.

- »*CT Type*« = "Relative" — Display of relative current values.
- »*CT Type*« = "WE2 : 16 A ... 56 A", ..., "W6 : 256 A ... 896 A" — Display of primary current values, based on this CT type.

From this CT type setting, together with the setting of »*In,relative*«, results the nominal current as a primary value, that is displayed at »*CT pri*«.

## 2.11 Condition Monitoring (Peak Current Ptr, Life Load)

There are two special statistical displays of the phase current values. These are available as table values and in form of special graphical diagrams. Since one of these is also able to issue an alarm signal, these kinds of statistics can also be interpreted as supervision functions:

- »Life Load« evaluates the operating days in dependency on the phase current flow and can (optionally) issue an alarm signal if the WIC1 has been running with too high load for a particular time. See [↳ “5.15.3 Condition Monitoring - Life Load”](#).
- »Peak Current Ptr« mimics an analog pointer instrument by calculating a time-average of the maximum phase current. See [↳ “5.15.3 Condition Monitoring - Life Load”](#).

Behind both types of statistics there is the general idea of checking whether the WIC1 - and therefore the protected object as well - have been under high load.

## 2.12 Reset

The menu item “Reset” offers commands to reset the latching of a particular state (“selective reset”), and in addition there are some collective resets available:

Type of Latched State	Reset of Several States at the Same Time			Selective Reset
	Automatic Reset	Manual Reset  (RESET button at DiggiMEC HMI)  (See also <a href="#">↪</a> “3.10.1.1 Front Panel Parts”.)	via Digital Input  (external reset)	Manually via Direct Control
Alarm-/Trip Cause display on the DiggiMEC HMI	✓	✓	✓	»Rst. LEDs, Fls«
DiggiMEC LEDs	✓	✓	✓	»Rst. LEDs, Fls«
DiggiMEC Outputs/Flag Indicators *	✓	✓	✓	
Thermal Level (of protection function »ThR«, see <a href="#">↪</a> “5.8 ThR - Thermal Overload [49]”)	—	—	—	»Rst. Thermal Lev.«
Flashing ERROR LED after a device-internal problem	—	—	—	»Rst. Err. LED«, see <a href="#">↪</a> “2.12.2 Notification of a Problem via LED”
Reset the WIC1 to factory defaults	—	—	—	»Factory Reset«, see <a href="#">↪</a> “2.13 Reset to Factory Defaults”

\* The WIC1 has an impulse output for setting a flag indicator, but it lacks an output for resetting it. Therefore only the DiggiMEC flag indicators can be set **and** reset by the WIC1. However, the reset of the DiggiMEC flag indicators is functional only if the WIC1 settings have specified which DiggiMEC variant is connected; the related parameter is [Device planning / WIC1 + DiggiMEC] »DiggiMEC . Mode«. In addition, DiggiMEC flag indicators can also be switched mechanically, by hand. (See [↪](#) “3.10.3 Flag Indicator / Output Relays Settings (DiggiMEC)”.) But note that such a mechanical change of state is **not** signaled back to the WIC1.

### NOTICE!



There is **no** latching of the WIC1-LED „Pickup/Trip“ (after a protection pickup / trip). Therefore there is no need for resetting it.

## 2.12.1 Automatic Reset

For some states it is possible to activate an automatic reset of the latching. This means that their latched state gets reset with each new (General) Pickup signal »Prot . Pickup« – and optionally once again after a particular timer, that is started when the (General) Pickup drops off, has elapsed.

Independent of this, it is also possible at any time to manually reset via DiggiMEC »RESET« key or via a digital input signal.

The following settings are available for this:

- For the latching of DiggiMEC flag indicators / output relays, [Device Para / DiggiMEC / FI / BO] »BO x latching« = “Latch. w. Auto-Reset”

(See also [↪ “3.10.3.1 Latching”](#).)

- For the latching of DiggiMEC LEDs, [Device Para / DiggiMEC / LEDs] »LED x latching« = “Latch. w. Auto-Reset”

See also [↪ “3.9.1.3 Latching of the DiggiMEC LEDs”](#).)

- The behavior of the automatic reset itself is set at [Device Para / Reset] »Def. Autom. Reset«

Note that the automatic reset is closely related to the (General) Pickup signal »Prot . Pickup«, and therefore we recommend to always use it only with states that indicate any protection pickup or trip.

If, however, an automatic reset is assigned to a state that is not related to any pickup or trip, the resulting reset behavior might be surprising (although it is exactly what one needs for real-life applications): Every protection pickup also issues the signal »Prot . Pickup«, see [↪ “5.1 »Prot« – General Protection Module”](#), and this signal starts the automatic reset. This means, of course, that all states (that are set to latching with automatic reset) get reset, and moreover, states that are assigned to this new protection pickup, get set (again). If the automatic reset is configured with a timer stage, for instance »Def. Autom. Reset« = “New Pickup or After 1 h”, then the timer starts when the signal »Prot . Pickup« drops off. And after the timer has elapsed, i. e. after one hour, all states (that are set to latching with automatic reset) get reset (again). So, unless there will be another protection pickup within this hour the result is that after one hour all states (that are set to latching with automatic reset) are reset.

But now let us consider a state, that is set to latching with automatic reset, but is assigned to some signal that is in no way related to any protection pickup or trip. This state would not get reset after one hour, because the timer stage always only starts when »Prot . Pickup« drops off. This means that only when a protection pickup should occur, will this state be reset (and once again one hour after the pickup drops off).

## 2.12.2 Notification of a Problem via LED

The second, red LED of the WIC1 can notify you of a device-internal problem by flashing red, see [↪ “The »System« LED\(s\) - “Ready”, “Error””](#). Contrast to a constant red illumination the flashing means that the overall protection functionality is fully active and not affected by the problem. Therefore it is possible to reset (“acknowledge”) the flashing LED.

This is done with the following Direct Control:

- [Operation / Reset] »Rst. Err. LED«

Although the protection functionality is essentially active it is apparently advisable to check for the problem that has caused the flashing LED, and for potential solutions. Check the entries in the Fault Recorder ([↪ “6 Fault Recorder”](#)) and the list of potential problems in [↪ “11 Troubleshooting”](#).

## 2.13 Reset to Factory Defaults

This Direct Control resets all parameters to their respective factory default:

- [Service / General] »Factory Reset«

This is the same functionality as keeping the DiggiMEC key »x« pressed during power-on, see [↩➡](#) “3.10.1.3 Special Keys During Power-on”.

### WARNING!



All parameter settings as well as the **password** will be reset. All records will be deleted and statistic values and counters will be reset.

Parameters that can be set via DIP/HEX switches will get the values as defined by the switches.

Exception: The operation hours counter is preserved.

Resetting to factory default is also required if a WIC1 that had been configured via DiggiMEC-/Smart view before shall be set back to settings via DIP/HEX switches; see [↩➡](#) “Validity of the DIP-/HEX-Switches”.

## 2.14 Security

### **Security-Related Messages**

Enter [Operation / Self-Supervision / Messages] »Messages« to access the list of [Self-Supervision Messages](#). This is a special Recorder that collects device-internal messages of various types, including security-related events. It is recommended to check these entries from time to time.

### 2.14.1 Password

The WIC1 supports an access password, that is required for any changes to the device settings (via DigiMEC and *Smart view*).

The menu item [Device Para / Security / Password] allows for setting an individual password. It is also possible to set it to an empty/blank text, and in this case the password query is skipped.

Up to four digits (i. e. only “0”...“9” are allowed for each position) are allowed for the password. The factory default is: »1234«

On the DigiMEC panel, the password is entered the same way as any numerical setting value, i. e. via navigation keys “◀” (Left), “▶” (Right) for the position (= selection of the position/digit within the password) and “▲” (Up), “▼” (Down) for increasing/decreasing the digit. The Enter key »↵« confirms the entered password. A Smart view user enters the password simply via the PC keyboard.

#### **Password Forgotten**

By pressing the »X« key during a cold restart a reset dialog is launched, see also [↪ “3.10.1.3 Special Keys During Power-on”](#). It allows for resetting all settings, including password, to the respective default.

This is the same functionality as the Direct Control [Service / General] »Factory Reset«, see [↪ “2.13 Reset to Factory Defaults”](#).

# 3 Hardware

## 3.1 Overview of Elements and Connectors

**NOTICE!**

**!** The controls and connectors, that the WIC1 is fitted with, depends on the [Order Form](#) of the WIC1.

**Front Side**

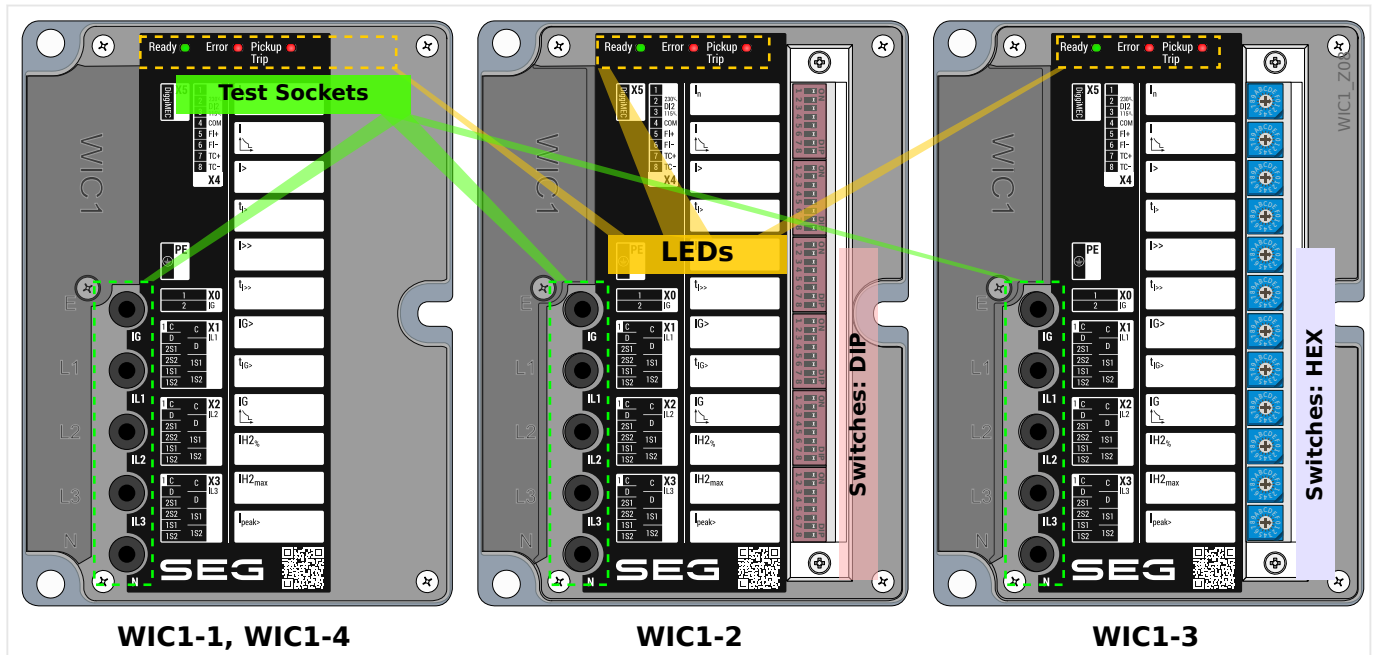
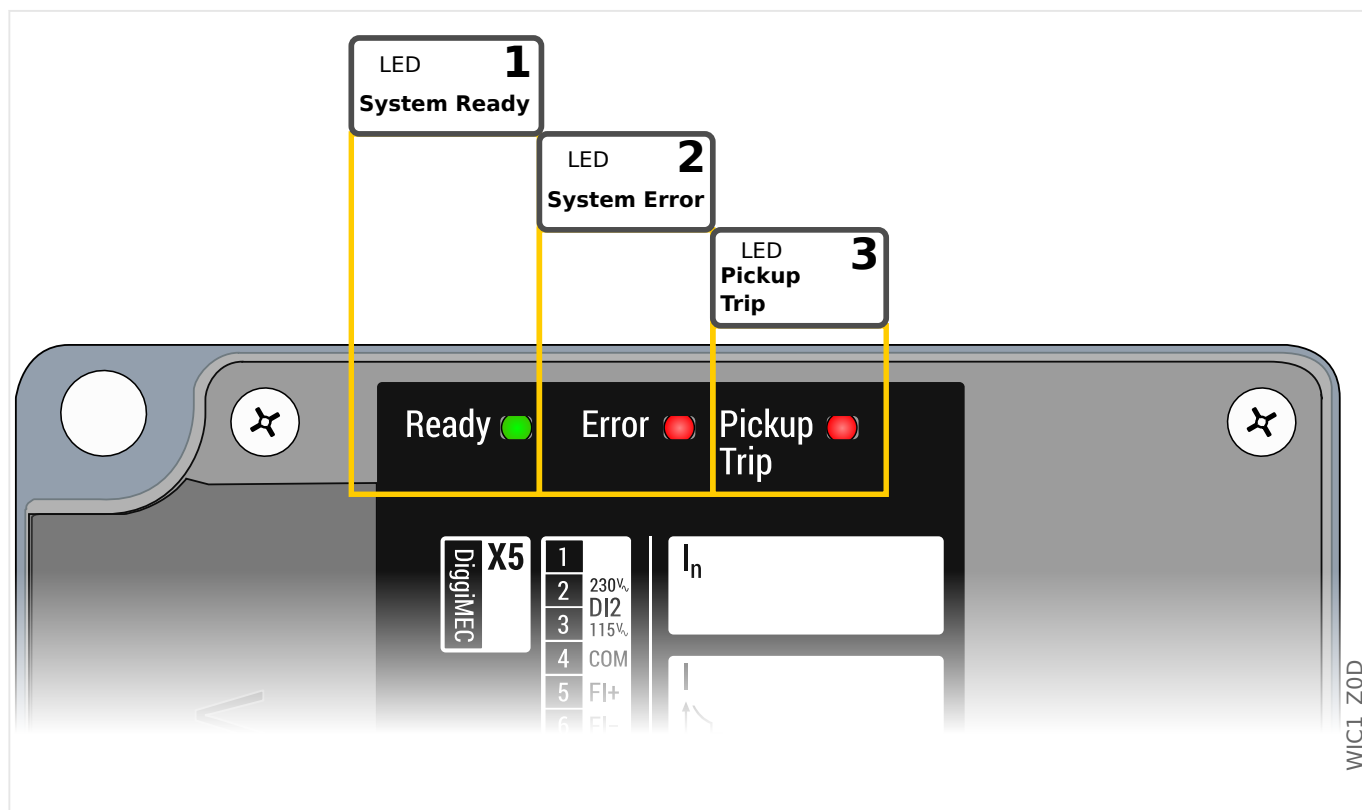

Fig. 5: Main elements at the front side of the WIC1.

The front side of the WIC1 is equipped with LEDs (for operation and alarm signals, see [“3.9.1 LEDs”](#)) and several test sockets, see [“8.1.4.1 Test Windings, Test Sockets”](#).



**LEDs**

- LED 1**      **System Ready:** This LED means: “Ready to Trip”. It is shining constantly green as soon as the WIC1 has (finished its booting process **and** and) loaded sufficient electrical energy for triggering the Trip impulse output. Details see [↪ “The »System« LED\(s\) - “Ready”, “Error””](#) and [↪ “3.8 Outputs \(Trip Coil, Flag Indicator, Relay Output\)”](#).
- LED 2**      **System Error:** This LED is flashing red or shining constantly red after a system error has occurred. Depending on the type and severity of this error either the non-protection functions are deactivated - protection is still operating - or only the (hardware-based) backup protection is available. Details see [↪ “The »System« LED\(s\) - “Ready”, “Error””](#) and [↪ “5.14 Integrated Backup Phase Overcurrent Protection”](#).
- LED 3**      **Pickup / Trip:** This LED is flashing red during a (General) Pickup, and it is shining constantly red while a (General) Trip occurs. See also [↪ “3.9.1.1 WIC1-LED for “Pickup / TripCmd””](#) and [↪ “5.1 »Prot« - General Protection Module”](#).

**Device Variants with Configuration Switches**

- Variant WIC1-2 is additionally equipped with DIP switches for configuration of protection parameters, see [↪ “12.1.1 Settings via DIP Switches \(WIC1-2\)”](#)).
- Variant WIC1-3 is additionally equipped with HEX switches for configuration of protection parameters, see [↪ “12.1.2 Settings via HEX Switches \(WIC1-3\)”](#)).

**Lateral Terminals**

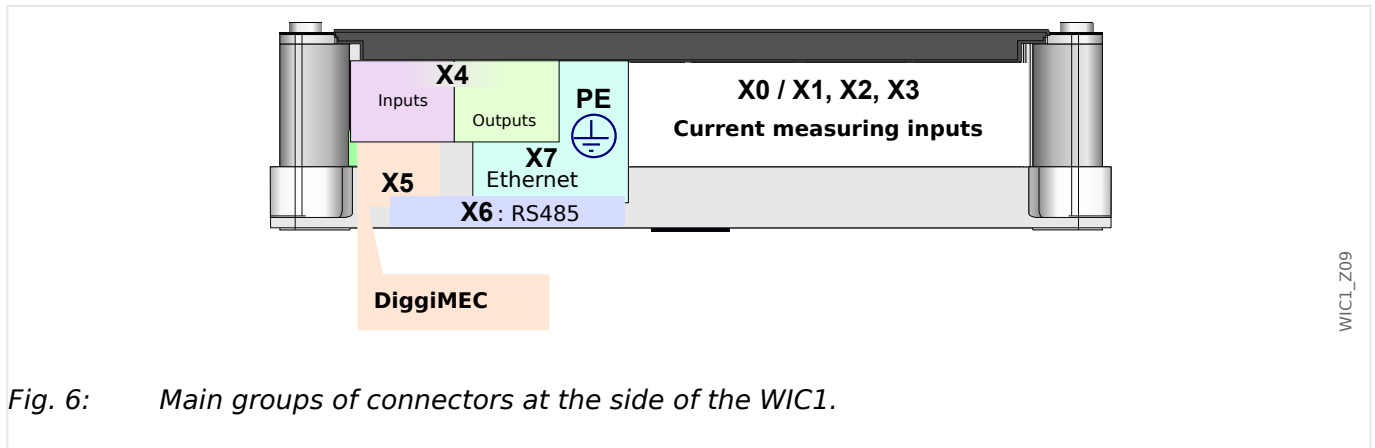

Fig. 6: Main groups of connectors at the side of the WIC1.

The WIC1 has all connectors located at one side of the housing, so that it is convenient to connect the required cables.

### 3.1.1 Terminals, Screws and Torques

#### CAUTION!



Be careful. Do not overtighten the mountings nuts of the relay. Check the torque by means of a torque wrench with respect to the max. torque values in the table. Overtightening the mounting nuts could cause personal injury or damage the relay.

Slot	Tightening Torques of the Screws	Screw Type	Description
PE	1.6 Nm (14.2 lb·in)	nut, 7 mm	Screw-type connector for Protective Earth. See <a href="#">↳</a> “3.3.1 Grounding”.
X0	0.5 Nm (4.4 lb·in)	M3 slotted	Measuring input for ground (earth) current (for some <a href="#">order options</a> ) — See <a href="#">↳</a> “3.4 Phase and Ground Current Measuring Inputs”.
X1, X2, X3	Inputs for <b>WIC1</b> CTs: 0.5 Nm (4.4 lb·in)	Inputs for <b>WIC1</b> CTs: M3 slotted	Measuring inputs for phase currents — See <a href="#">↳</a> “3.4 Phase and Ground Current Measuring Inputs”.
X4	0.5 Nm (4.4 lb·in)	M3 slotted	Pin assignments depending on the <a href="#">order option</a> , for example: <ul style="list-style-type: none"> <li>• Impulse signal outputs for a trip coil and for a flag indicator — See <a href="#">↳</a> “3.8 Outputs (Trip Coil, Flag Indicator, Relay Output)”.</li> <li>• Only some variants of WIC1-1... / WIC1-2... / WIC1-3...: Input e. g. for an external trip signal — See <a href="#">↳</a> “3.5 Digital Input (only WIC1-1... / WIC1-2... / WIC1-3...)”</li> <li>• Only WIC1-4...: Digital Inputs incl. additional auxiliary power supply — See <a href="#">↳</a> “3.6 Additional Power Supply and Digital Inputs (WIC1-4... only)”</li> </ul>
X5	—	—	RJ45 connection to the DiggiMEC.  Ethernet CAT3 cable or better, but beware, this is not an Ethernet connection! Beware, <b>crossover cables must not be used!</b>  See also <a href="#">↳</a> “2.7 Settings - Operation”.
X6	0.22 Nm (1.9 lb·in), except:  two screws for fixing the connector: 0.3 Nm (2.6 lb·in)	M3 slotted, except:  two screws for fixing the connector:  M2 slotted	Only some variants of WIC1-4:  RS485 connector for SCADA communication. <b>Note that SCADA will become available with a later release.</b>
X7	—	—	Only some variants of WIC1-4:  RJ45 or fiber optics connector for Ethernet-based SCADA communication. <b>Note that SCADA will become available with a later release.</b>
—	0.6 Nm (5.3 lb·in)	M3 crosshead	Plastic cover for protecting and covering the lateral terminals, fastened with one non-losable screw.
—	0.6 Nm (5.3 lb·in)	M3 crosshead	Only for variants of WIC1-2, WIC1-3:  Plastic cover for the DIP/HEX switches, fastened with two non-losable screws.

### 3.2 Dimension Drawings

#### 3.2.1 WIC1 Dimension Drawings

All WIC1 variants are of the same standardized design. Therefore the dimension diagrams below are not meant to be restricted to a particular variant.

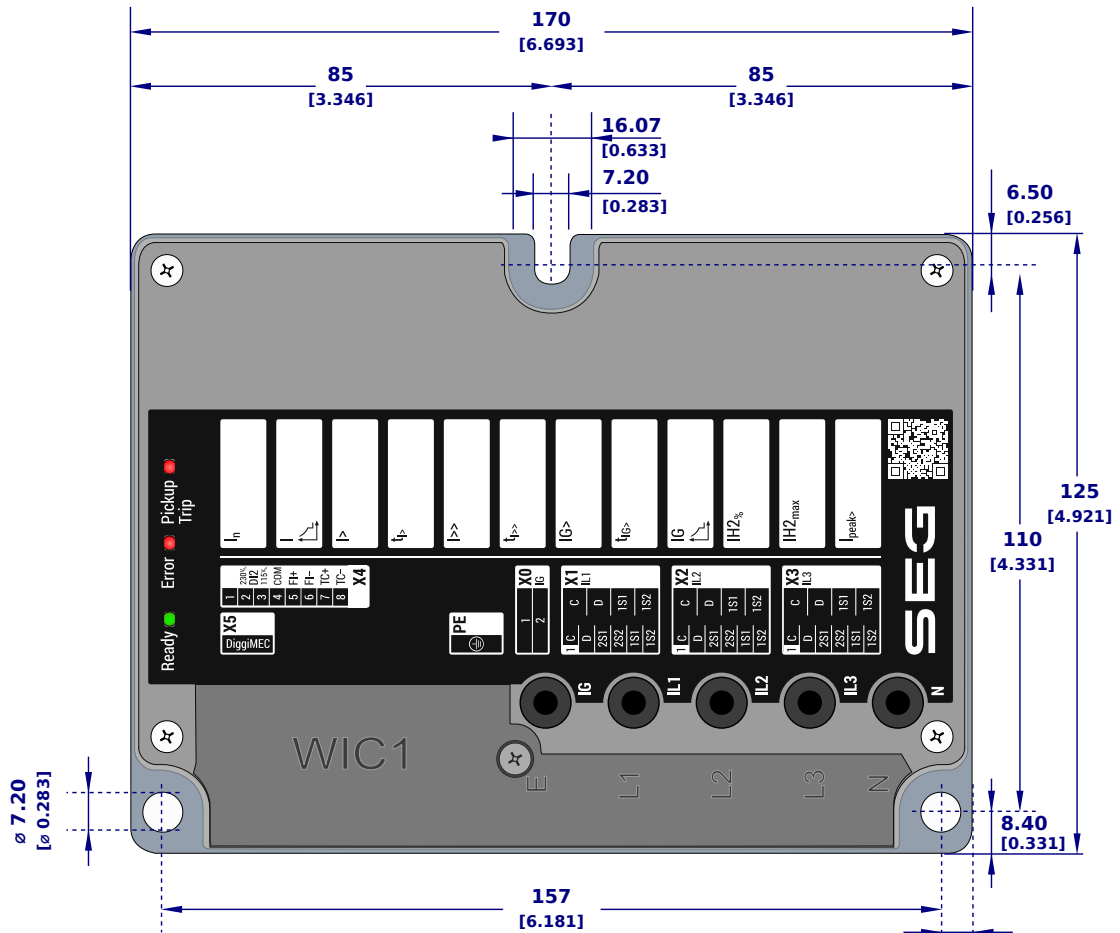

WIC1\_Z02

Fig. 7: WIC1, top view. All dimensions in mm, except dimensions in brackets [inch].

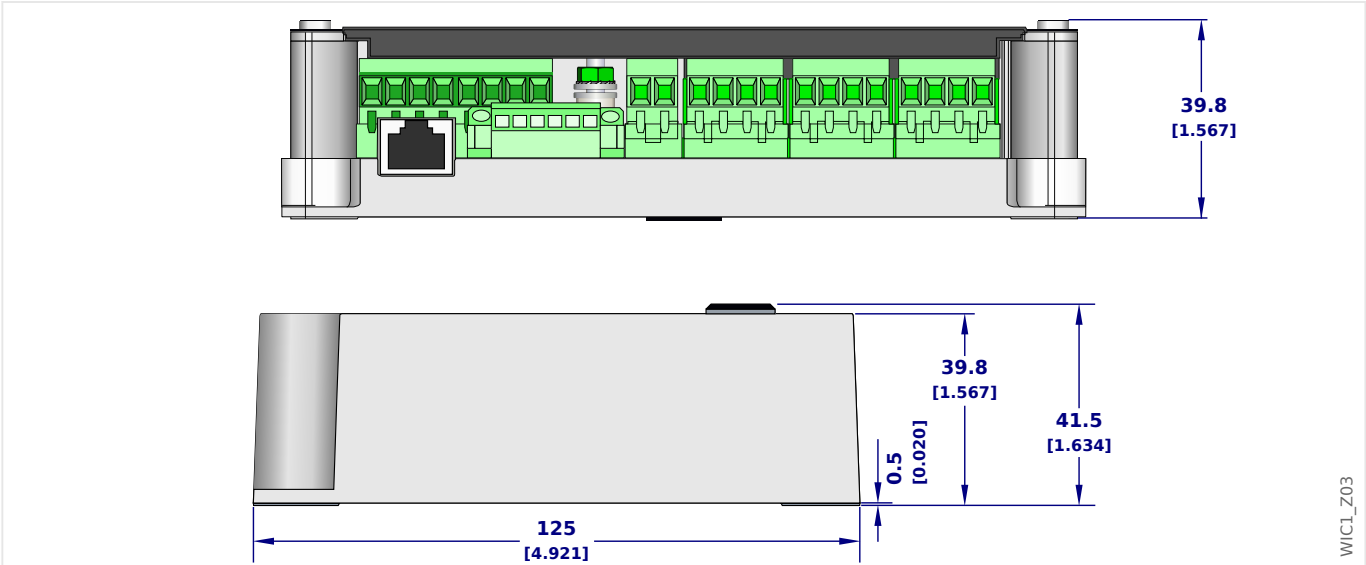

Fig. 8: WIC1, 2 sides view. All dimensions in mm, except dimensions in brackets [inch].

**NOTICE!**



Dependent on the connection method of the SCADA system used the needed space (width) differs. If, for instance, a device variant with an RS485-plug is used, it enlarges the width dimension.

### 3.2.2 DiggiMEC Dimension Drawings

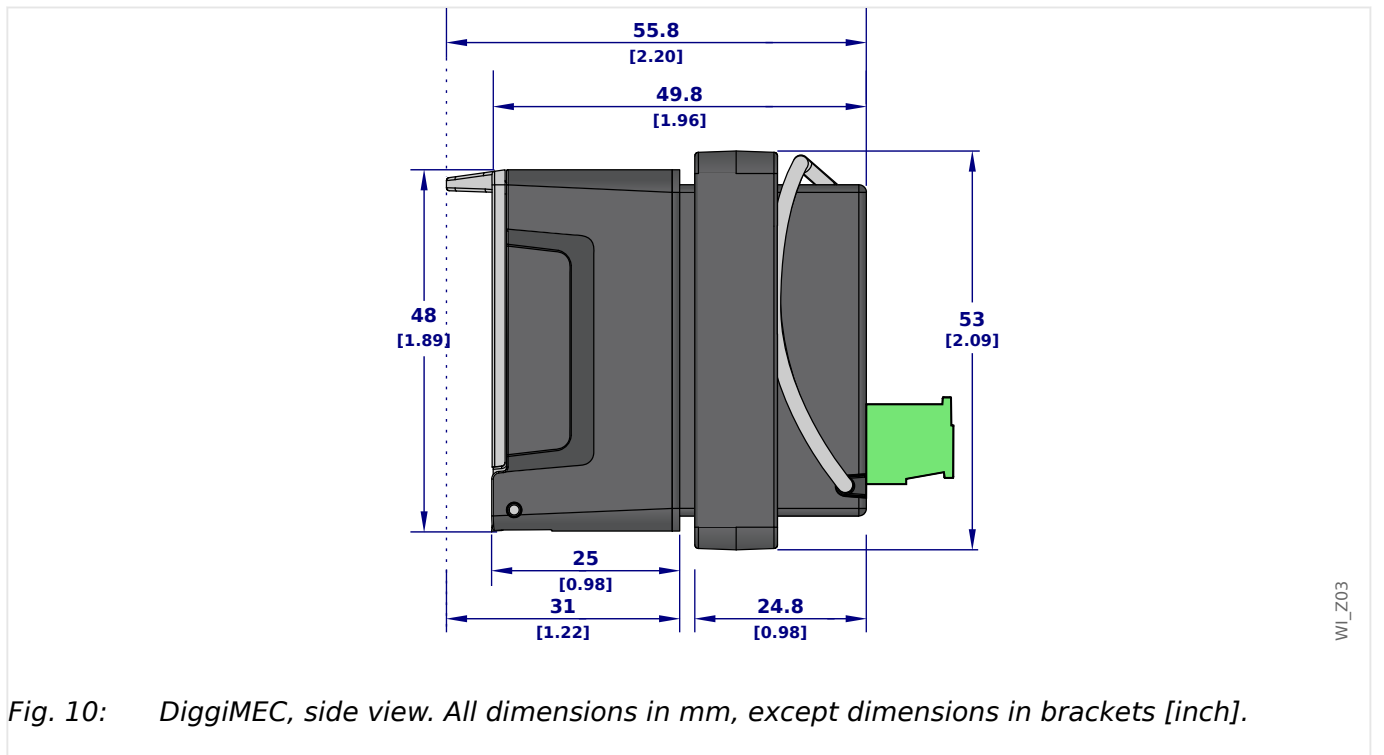
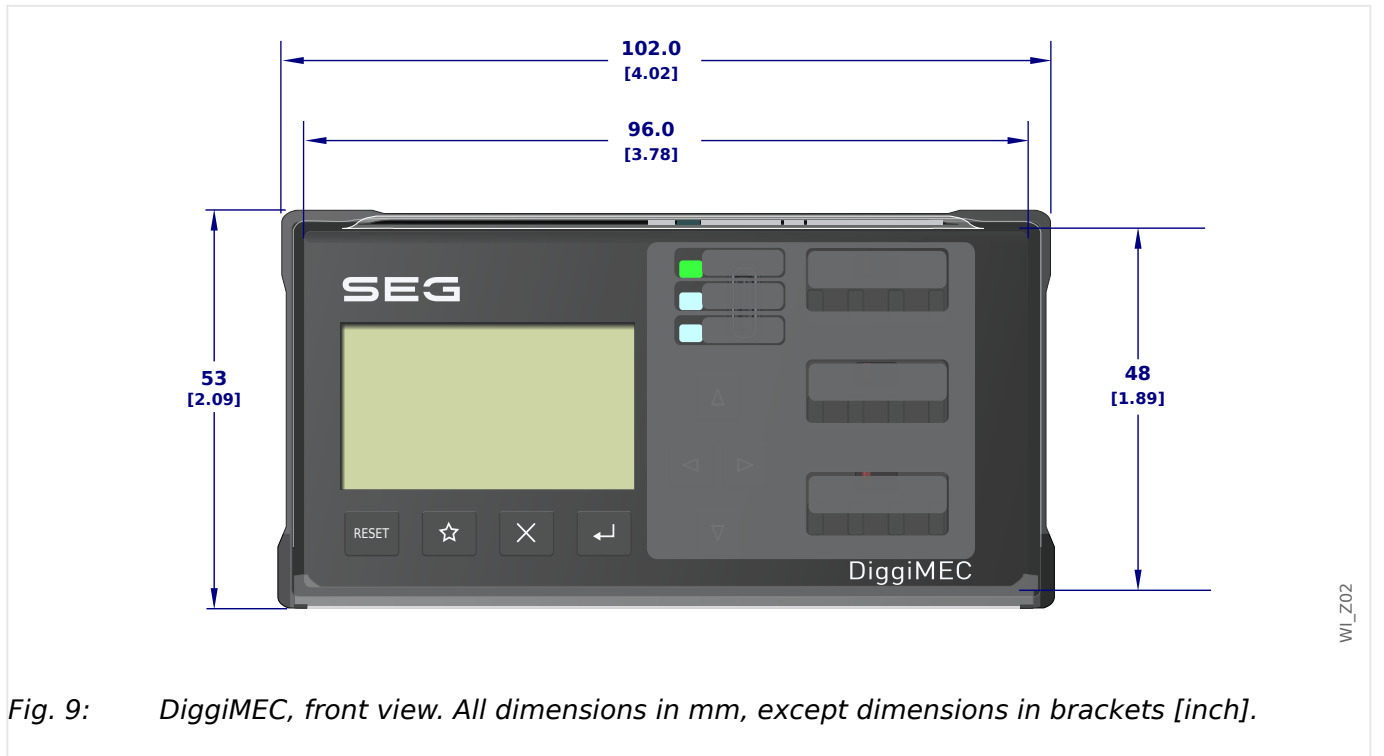

### Installation Diagram - Cutout for Door Mounting of the DiggiMEC

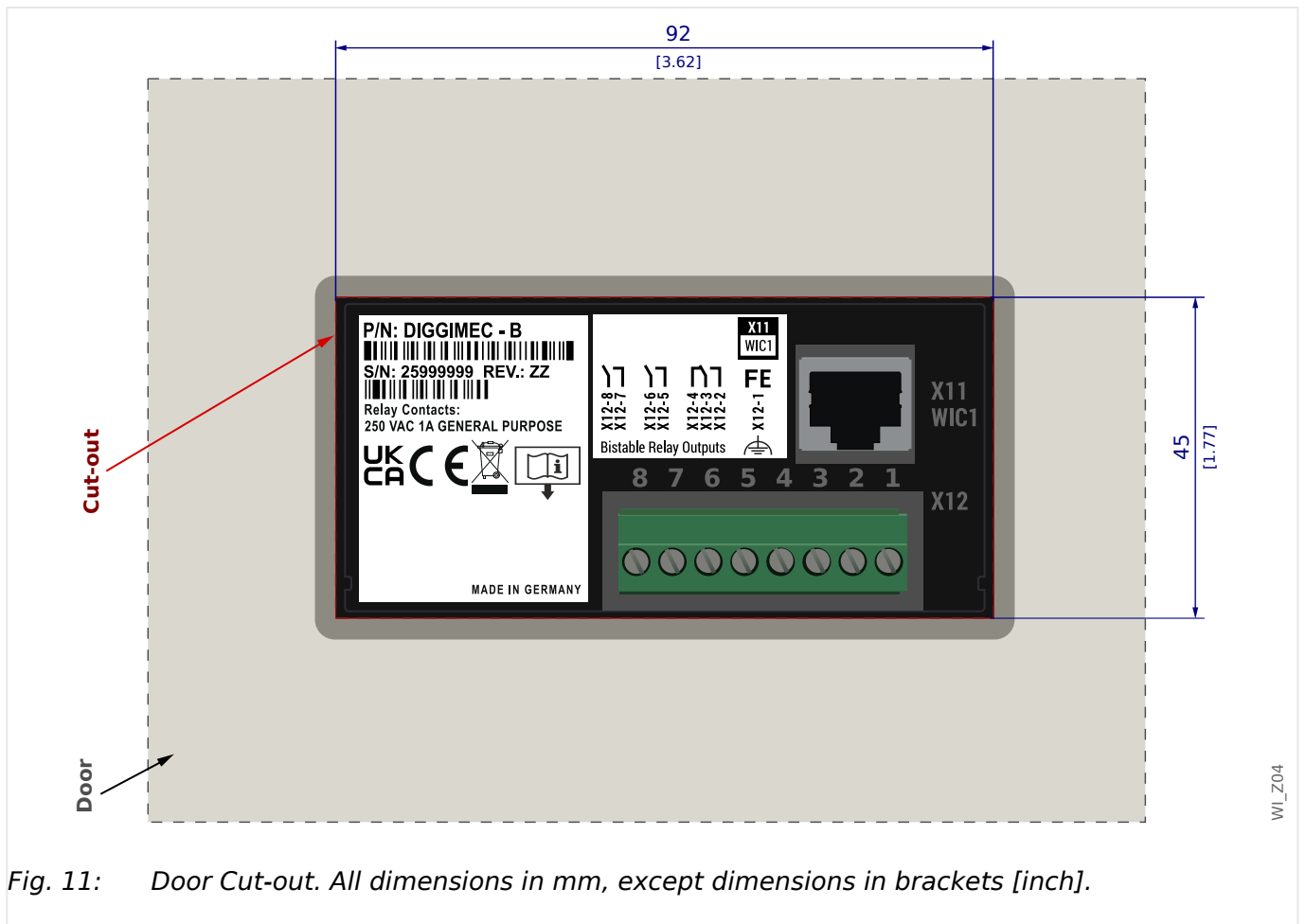



Fig. 11: Door Cut-out. All dimensions in mm, except dimensions in brackets [inch].

The DiggiMEC can be mounted into a standard door cutout, that is already available by default with most cabinets.

The rear side (  “3.10.2 DiggiMEC Connectors”) features an RJ45 plug: It may only be used to connect the DiggiMEC with a WIC1.

### 3.2.3 Dimension Drawings of the WIC1-Compatible Current Transformers

#### Construction Type 1

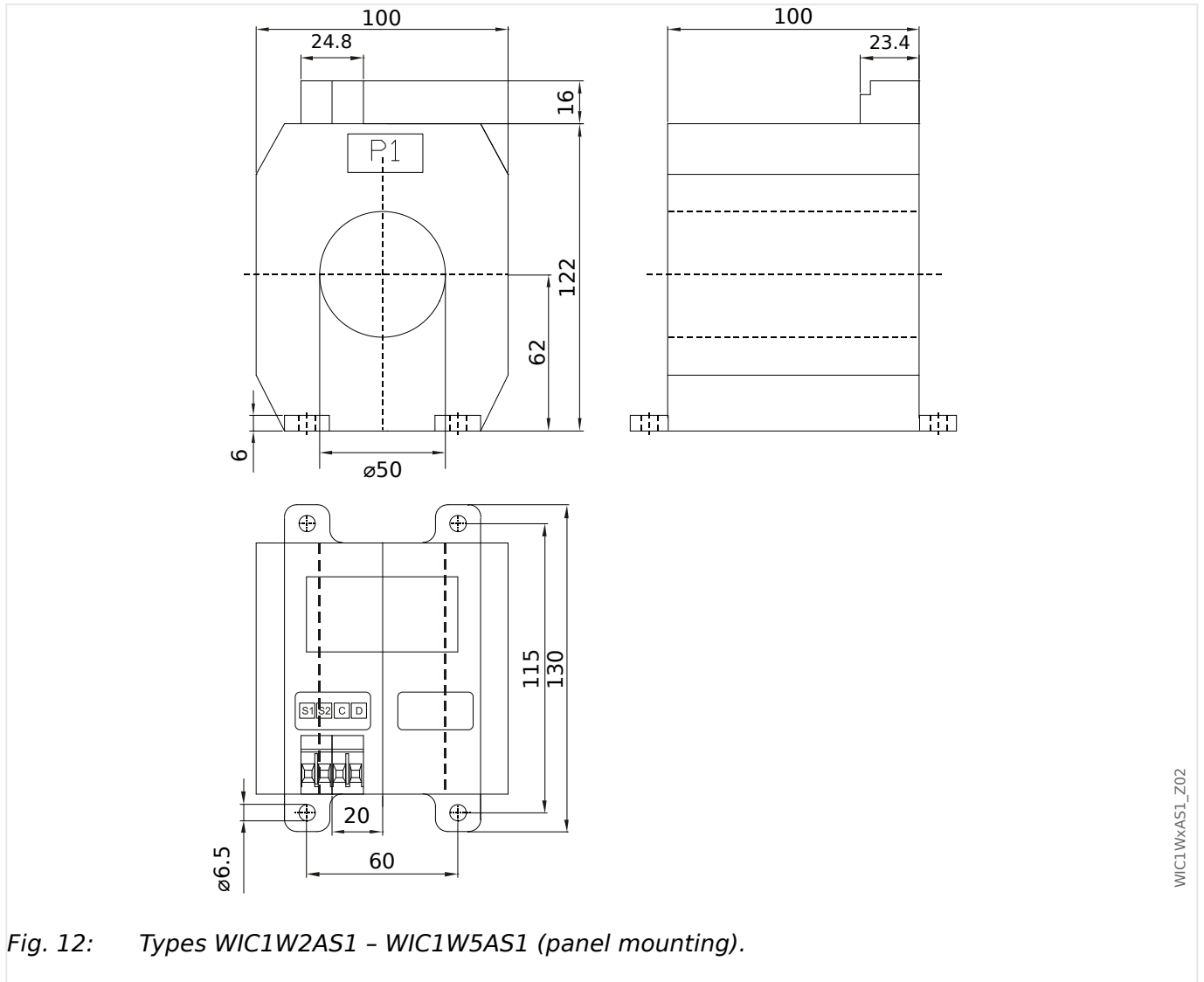
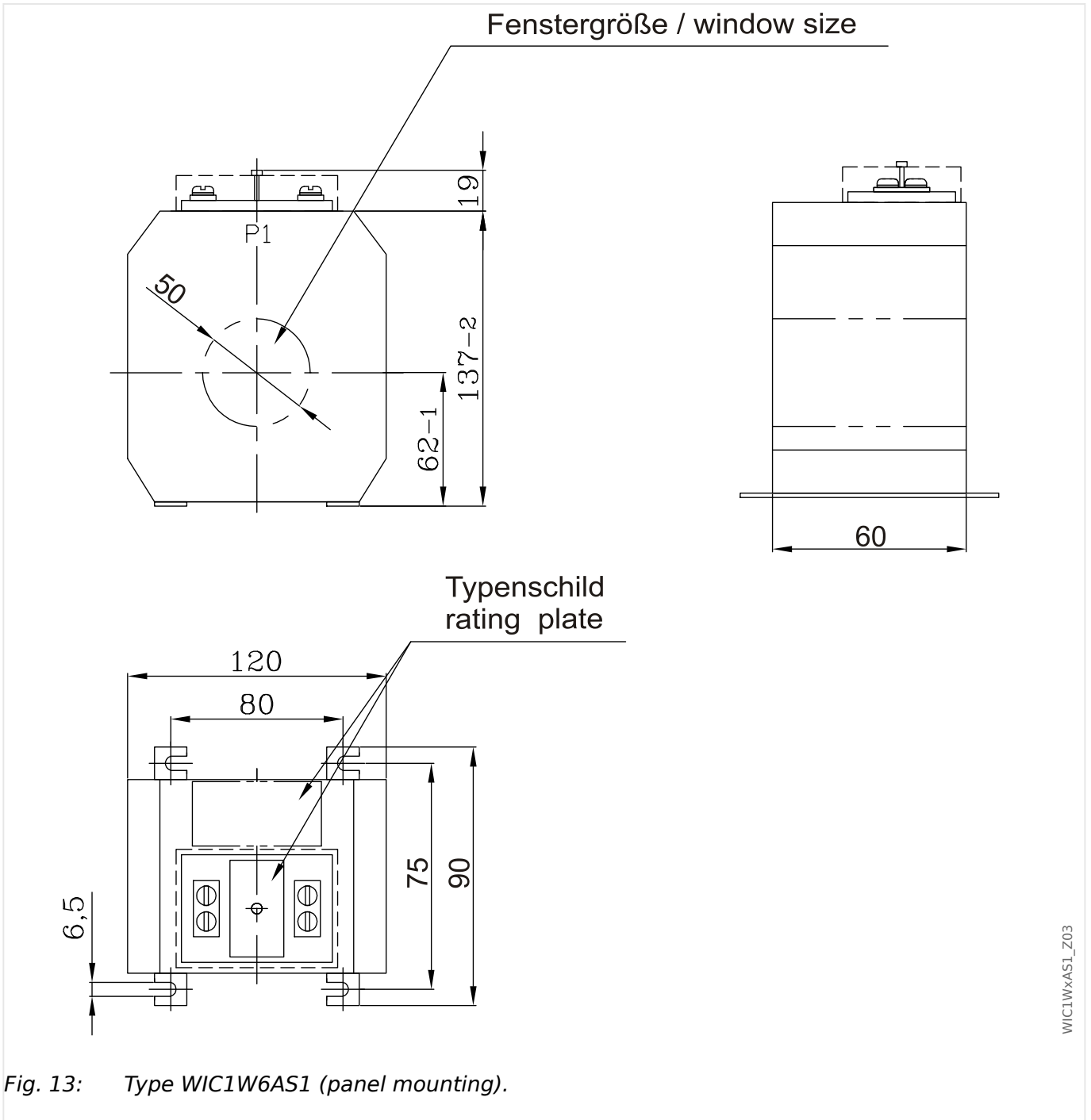

Fig. 12: Types WIC1W2AS1 - WIC1W5AS1 (panel mounting).





WIC1W6AS1\_Z03

Fig. 13: Type WIC1W6AS1 (panel mounting).

**Construction Type 2**

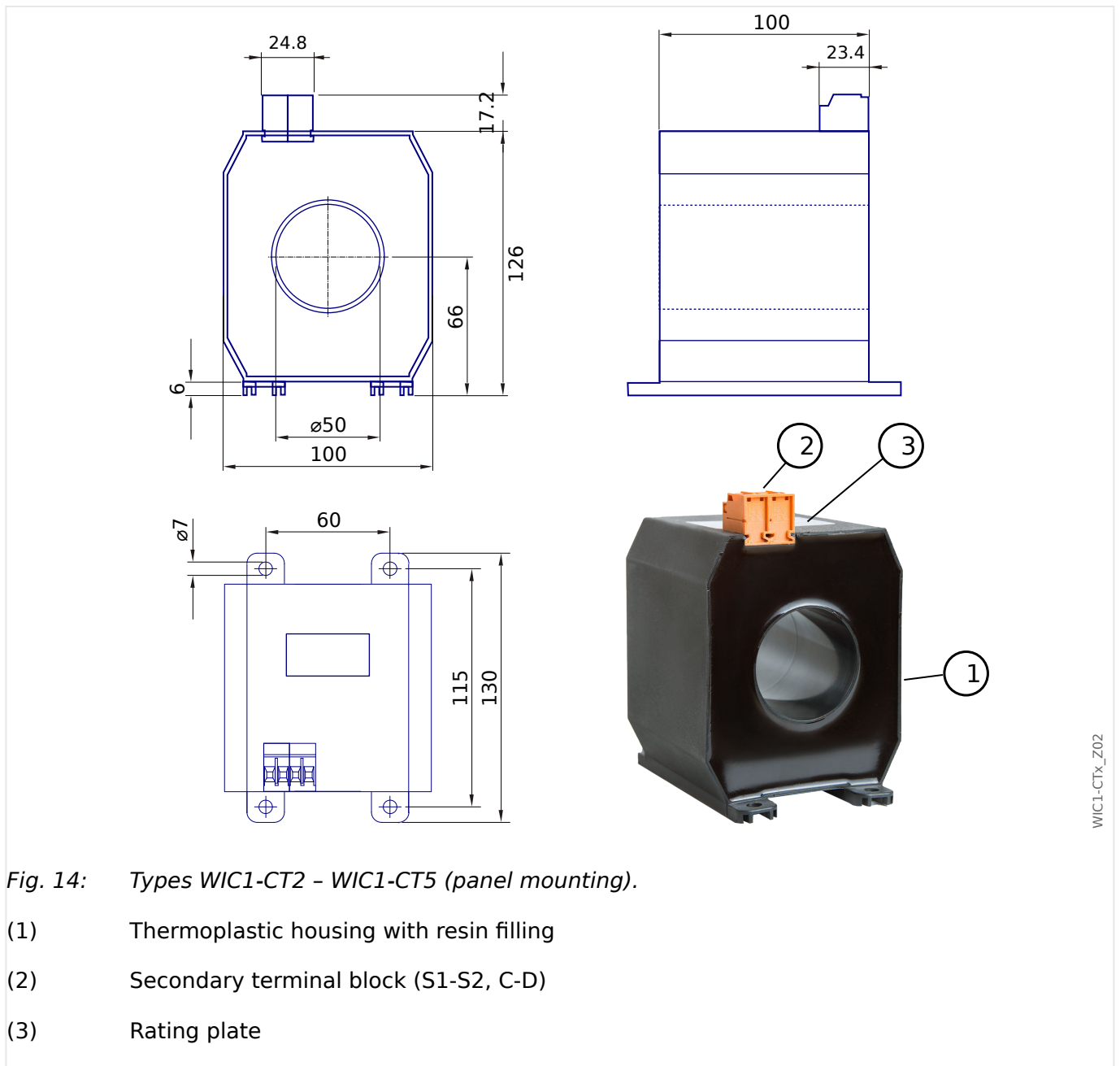

WIC1-CTX\_Z02

**Adapter CTs for 1 A / 5 A**

Fig. 15: Adapter CT, WIC1-CT-1A / WIC1-CT-5A (panel mounting).

- (1) Thermoplastic housing with resin filling
- (2) Connection cables, 2.5 mm<sup>2</sup>, length = 3000 mm
- (3) Rating plate

**WARNING!**

Due to technical constraints with respect to construction, the Adapter CT has a window, just like the feed-through of a standard CT. But it is not permitted to mount an MV / primary current cable through this Adapter CT window!

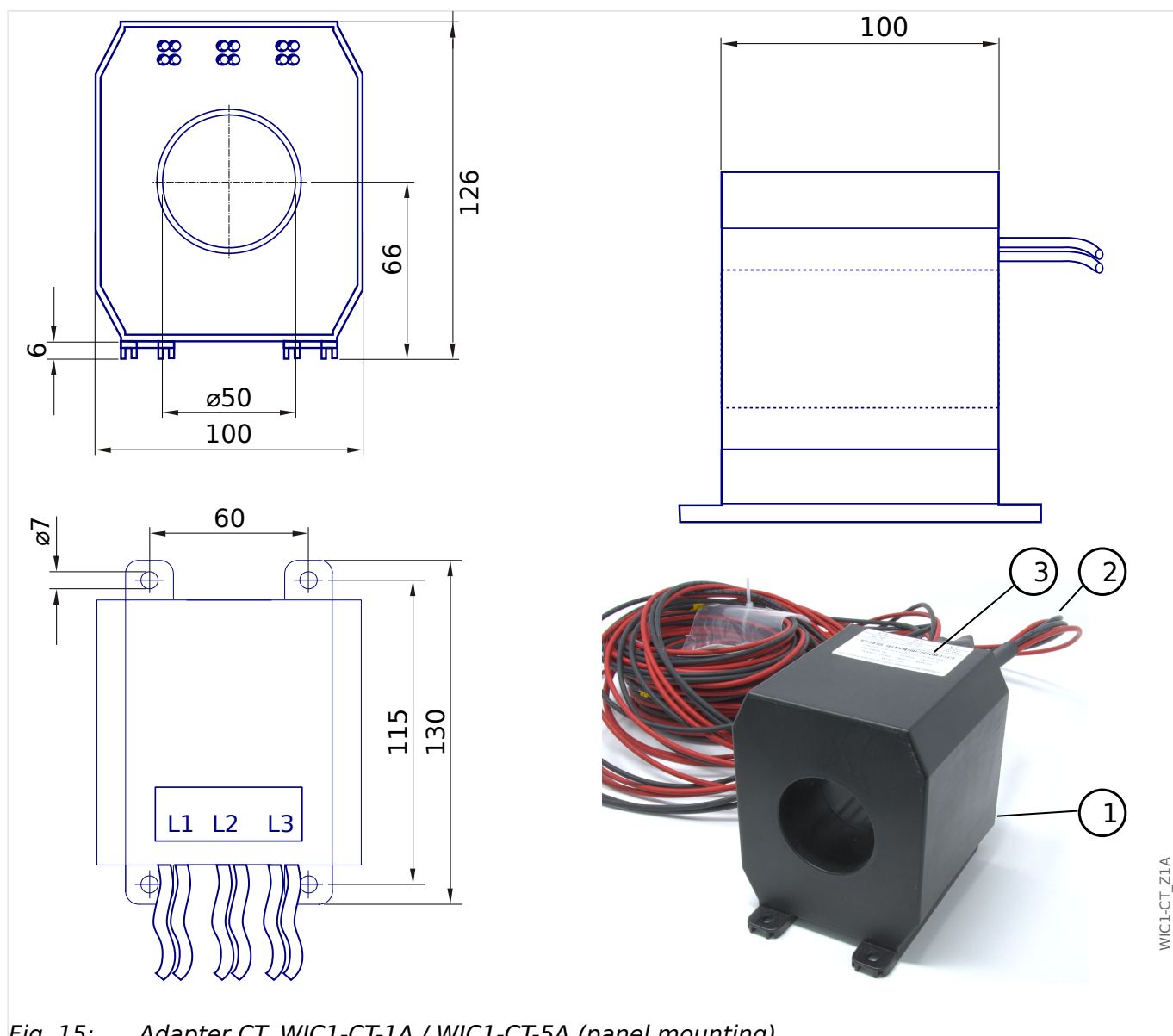
Ignoring this can result in dangerous voltages at the contacts, and due to wrong measuring values there would not be any effective protection of your equipment.

**NOTICE!**



Please note also these peculiarity, that are inherent to the construction of the Adapter CTs:

- The housing (see [Fig. 15](#)) contains three Adapter CTs, so that all three phase currents are covered. Therefore you need to buy only one unit, see also [“Adapter CTs for 1 A or 5 A”](#).
- There are no test windings. Therefore the test sockets of the WIC1 **cannot** be used with the Adapter CTs.

### 3.2.4 Dimension Drawing of the Flag Indicator WI1SZ5

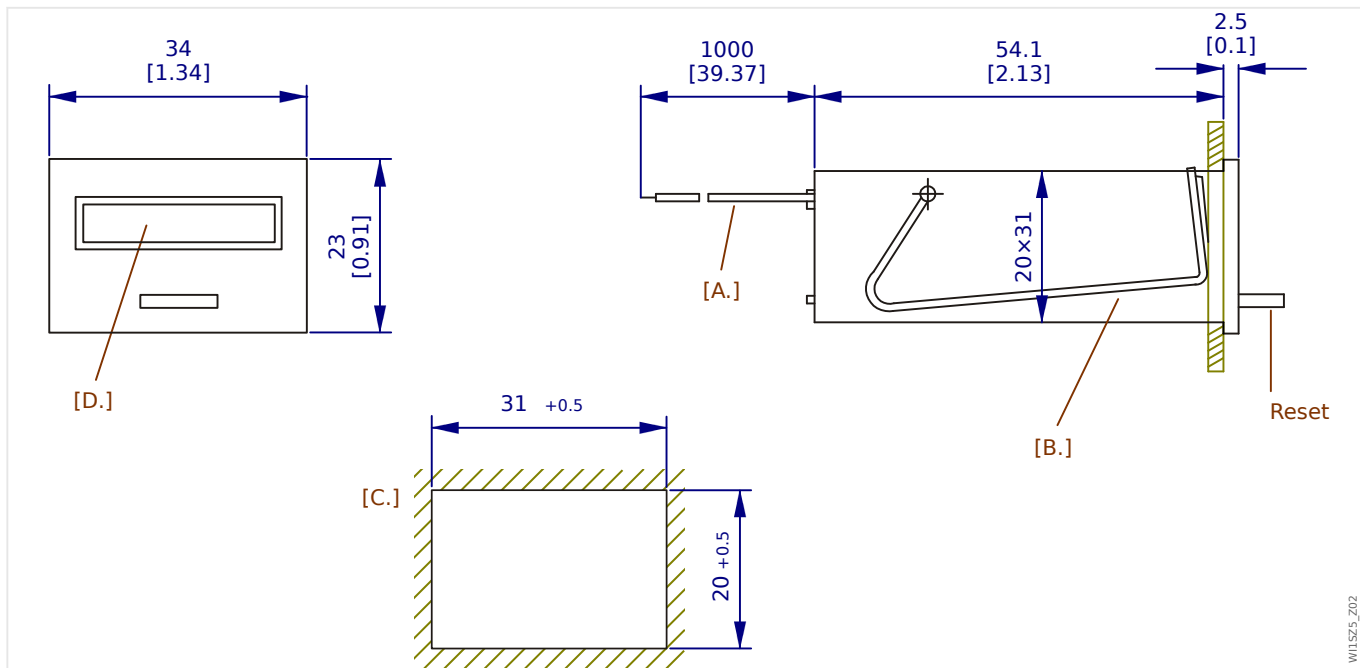

Fig. 16: Dimension Drawing for the WI1SZ5 flag indicator. (All dimensions in mm, except dimensions in brackets [inch].)

- [A.] Connection cables
- [B.] Fastening bracket
- [C.] Cut-out dimensions
- [D.] Display

WI1SZ5\_202

### 3.3 WIC1 - Installation and Wiring

#### 3.3.1 Grounding

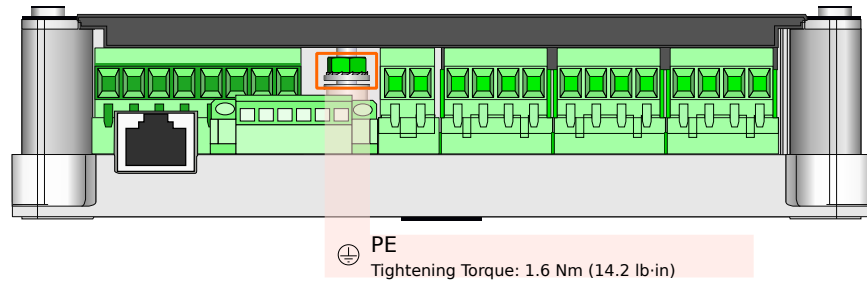

Fig. 17: The grounding cable is fastened using the “PE” screw-nut.

#### WARNING!



The housing must be carefully grounded.

- Connect a ground cable (protective earth, 4 to 6 mm<sup>2</sup> [AWG 11–9], tightening torque 1.6 Nm [14.2 lb-in]) to the housing, using the nut that is marked with the “PE” symbol. (See also [↪ “3.3.1.1 Nut “PE” for Grounding”](#).)

All grounding connections (i. e. protective earth) must be low-inductance, i. e. as short as possible, and national standards – if applicable – must be followed.

#### CAUTION!



The devices are very sensitive to electro-static discharges.

A tabular overview of all terminals can be found in [↪ “3.1.1 Terminals, Screws and Torques”](#) zu finden.

#### CAUTION!



The measuring winding (terminals S1 and S2, and – if available – S3, S4) of the CTs must not be earthed, otherwise the measurement results are distorted, ensuring in erratic behavior of the WIC1.

### 3.3.1.1 Nut "PE" for Grounding

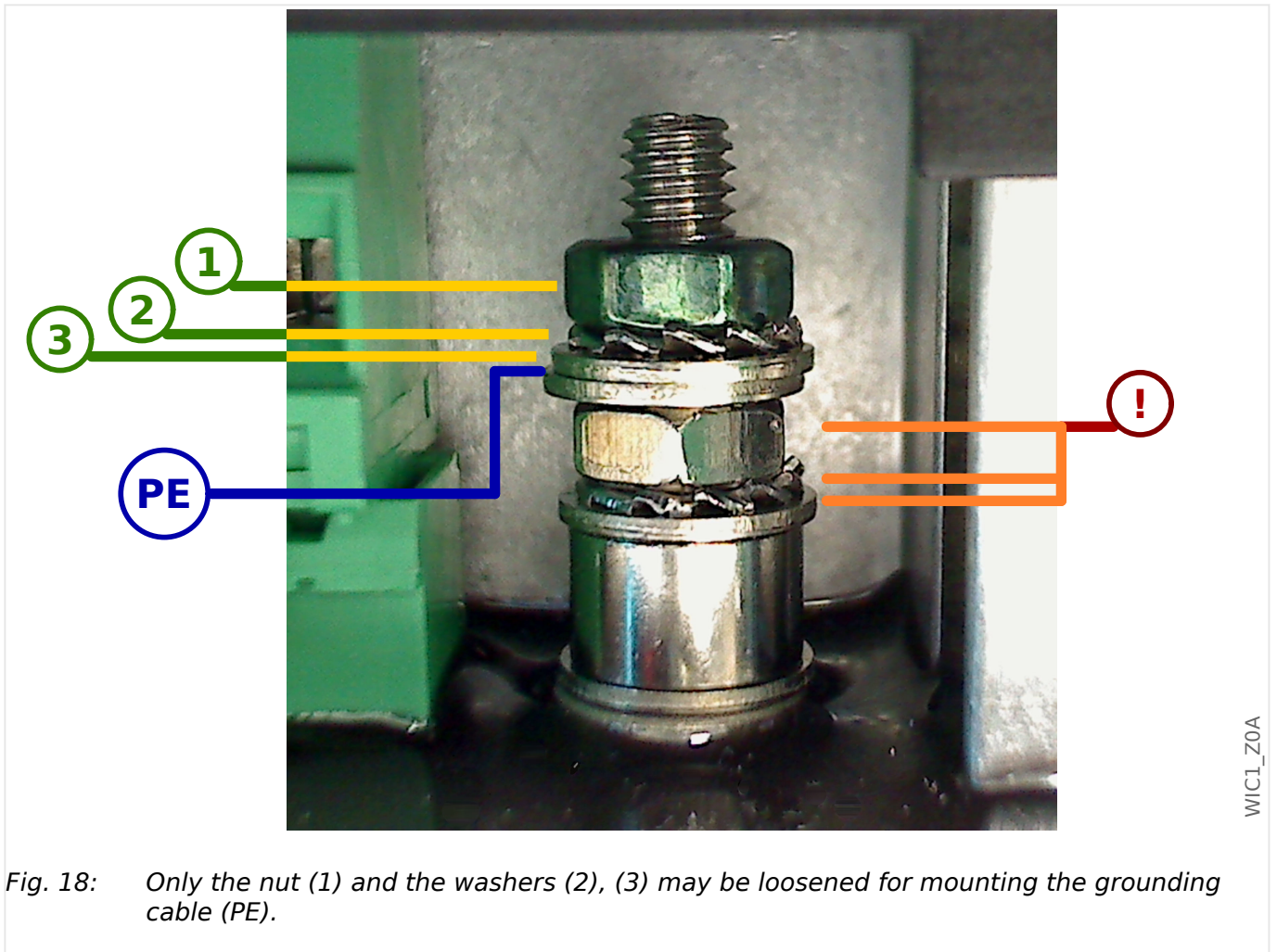

Fig. 18: Only the nut (1) and the washers (2), (3) may be loosened for mounting the grounding cable (PE).

The grounding cable has to be furnished with a ring-terminal, that gets fastened between two washers, see the blue "PE" marking in the image above.

First you have to remove the nut (1), the serrated lock washer (2) and the upper washer (3), then mount the eye of the ring-terminal, finally fasten the nut and washers again (tightening torque: 1.6 Nm [14.2 lb·in]).

The lower parts that are marked with the red (!) in the image **must** be kept fixed all the time!

### 3.3.2 Selection of a WIC1-Compatible Current Transformer

#### DANGER!



The terminal block for connection to the current transformers is not a shorting block. Therefore always short-circuit current transformers before loosening the terminals.

Ignoring this can result in dangerous voltages at the open contacts (up to dozens of kilovolts depending on the CT type).

#### DANGER!



The WIC1-compatible current transformers are dimensioned for nominal voltages < 1000 V. This means for an application in MV-switchboards (i. e. voltages < 36 kV) that these current transformers may only be used with insulated primary conductors, for example cables, with appropriate insulation resistance against earth. These current transformers are not allowed to be used for non-insulated primary conductors > 1000 V against ground (earth).

In addition, the medium voltage cables, whose phase currents shall be measured via the CTs, must be furnished with a grounded/earthed shielding.

Ignoring this can result in dangerous voltages at the open contacts (up to dozens of kilovolts depending on the CT type).



For the test winding, see the [Commissioning](#) chapter, in particular [↪ “8.1.4.1 Test Windings, Test Sockets”](#).



### 3.3.2.1 Current Ranges of the WIC1-CTs

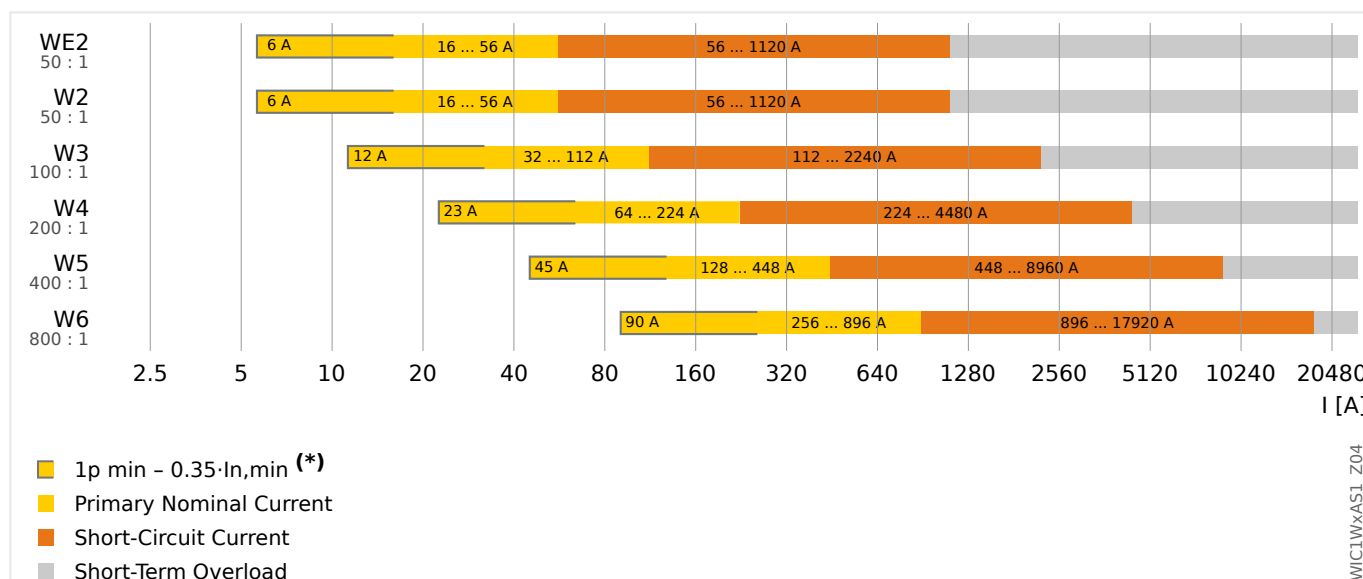

Fig. 19: Current Ranges for the WIC1-compatible CTs.

\* 1p min: Via DiggiMEC/Smart view, the WIC1 can be functional starting at 0.35 In<sub>min</sub> (1-phase supply). The related setting values, however, cannot be set via DIP/HEX switches.

The current ranges for the WIC1-compatible CTs are as follows:

CT Type	3p min (*) (Min. Supply in 3 Phases) [A]	1p min (*) (Min. Supply in 1 Phase) [A]	In <sub>min</sub> [A]	Range of In (**) [A]	Short-Circuit Range (***) [A]	Continuous Thermal Withstand [A]	Short-Term Overload (approx. 1 s) [A]
W2	4	6	16	16 ... 56	56 ... 1120	≤ 140	1120 ... 25000
WE2	4	6	16	16 ... 56	56 ... 1120	≤ 140	1120 ... 25000
W3	8	12	32	32 ... 112	112 ... 2240	≤ 280	2240 ... 25000
W4	16	23	64	64 ... 224	224 ... 4480	≤ 560	4480 ... 25000
W5	32	45	128	128 ... 448	448 ... 8960	≤ 1120	8960 ... 25000
W6	64	90	256	256 ... 896	896 ... 17920	≤ 2240	17920 ... 25000

- (\*) See also [Technical Data](#), [10.1.6 Power Supply](#).
- (\*\*) Primary Rated CT Current in Ampere, see also [12.1.3.1 DIP-/HEX-Switch Settings for CT Types W2, WE2](#).
- (\*\*\*) The measuring range of the WIC1 ends at the maximum short-circuit current. Beyond this value there is no more increase of the device-internal measured value.

### 3.3.2.2 CT Type WE2

In case of small values of the primary currents there is a special “E”-labeled CT available that features a mixed core based on MU metal and offers an optimized transmission characteristic: WIC1WE2AS1.

It is typical of self-powered protection relays such as the WIC1 that small primary currents cause a non-linear transmission characteristic of the relay.

The “E” CTs improve the accuracy of the whole system if the primary current values are less than 16 A.

A worse accuracy can often be accepted for an application without a calculation-based ground current protection, so that the WIC1W2AS1 (i.e. without „E“) represents an inexpensive alternative. If a higher accuracy is needed, or in case of a required earth current protection element it is recommended to always use an “E”-type CT (i.e. prefer WIC1WE2AS1 over WIC1W2AS1), because in the lower operation range this CT type is more precise than the WIC1W2AS1.

### 3.3.2.3 Selection of the CT Transformation Voltage Ratio

Selection of the CT suitable for the WIC1 depends on the rated current of the transformer to be protected. It can be calculated according to the following formula:

$$I_n = \frac{S_n}{\sqrt{3} \cdot V_n}$$

※

#### Example:

- $S_n = 1600 \text{ kVA}$
- $V_n = 10 \text{ kV}$

The resulting nominal current is:  $I_n = 92.4 \text{ A}$

Check the table of available CTs in [↳ “2.6.1.3 Order Form of the WIC1-Compatible Current Transformers”](#) or [↳ “3.3.2.1 Current Ranges of the WIC1-CTs”](#), and you find that both **W3** and **W4** are suitable for this nominal current.

Further criteria can now be applied to pick one out of these suitable CTs.

- Short-circuit transient characteristic:

The WIC1 can measure a short-circuit current of a circuit up to 20 times of the upper rated CT current. (See also the red bars in diagram [↳ Fig. 19.](#))

This means for the selected CT:

**W3:**  $112 \text{ A} \times 20 = 2240 \text{ A}$ , or

**W4:**  $224 \text{ A} \times 20 = 4480 \text{ A}$ .

If the short-circuit current of a circuit is approx. 3 kA, for example, because of the location, then the preference should be given to the **W4**, so that the current can be measured cleanly by the WIC1.

- Operating current:

The operating current should be in the rated CT current range. The WIC1 system can be loaded continuously up to 2.5 times of the upper rated CT current. (See [↳ “3.3.2.1 Current Ranges of the WIC1-CTs”](#).)

This has no effect on the measurement of the overload. But due to the limitation of the measurement to 20 times the upper rated CT current, the short-circuit protection is limited.

- Accuracy of current measurement:

For low current, the accuracy is better if *»In,relative«* (see [↳ “12.1.3 Setting of the Rated CT current In”](#)) may be set to a higher value, which means a preference for **W3**, especially if low protection thresholds are planned.

For high phase currents, however, and/or if DC offset signals are possible, the accuracy is better if *»In,relative«* is low, which means a preference for **W4**, especially with respect to CT saturation effects and to reliability of [inrush blocking](#).

- Trip times:

Trip times, as measured for an initially switched off WIC1, may be slightly faster for a higher *»In,relative«* because [collecting enough electrical energy](#) for a trip pulse is faster. This is especially true if a DigiMEC is connected that also drains a little bit of energy. This would be a preference for **W3**.

The calculated nominal current  $I_n = 92.4 \text{ A}$  is settable in the WIC1, see [↳ “12.1.3 Setting of the Rated CT current In”](#).

- **W3**:  $92.4 \text{ A} = 2.887 \cdot I_{n,\min}$ ,
- **W4**:  $92.4 \text{ A} = 1.443 \cdot I_{n,\min}$ .

We listed several criteria in favor of **W3** and **W4** above. Since these depend on the individual preferences of the application it is not possible to give a general rule that meets all aspects. From our experience we can conclude that most real-life applications should select a CT such that *»In,relative«* is within the range  $I_{n,\min} \dots 2.5 \cdot I_{n,\min}$ . This would prefer the “higher” CT in our example, i. e. **W4**, and the related setting *»In,relative«* =  $1.443 \cdot I_{n,\min}$ . Of course, this setting value cannot be set exactly with DIP or HEX switches, for these WIC1 variants the best settable value is *»In,relative«* =  $1.5 \cdot I_{n,\min}$ .

**Quick Pick: Look up the CT**

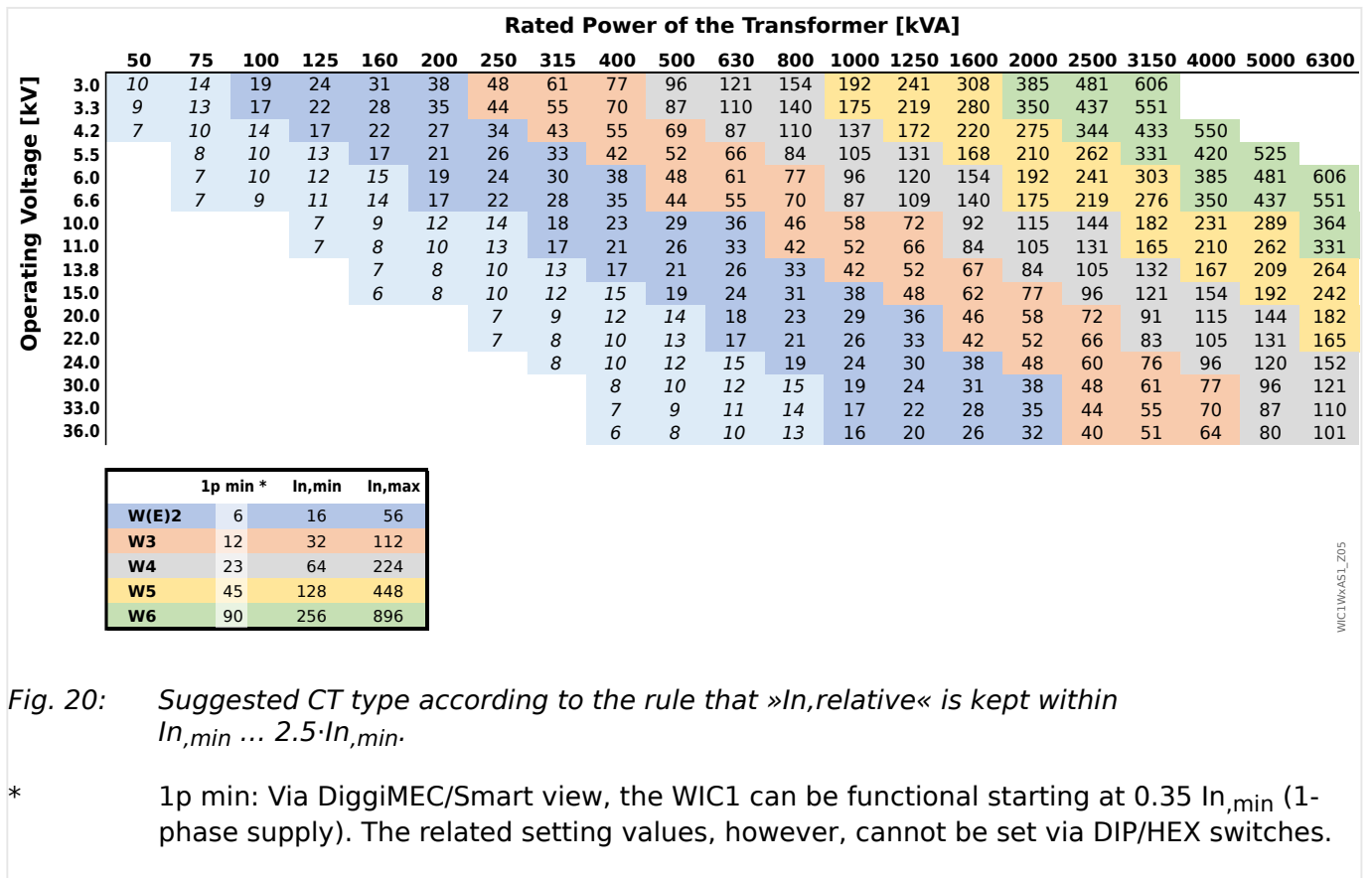

Fig. 20: Suggested CT type according to the rule that »In,relative« is kept within  $In,min \dots 2.5 \cdot In,min$ .

\* 1p min: Via DiggiMEC/Smart view, the WIC1 can be functional starting at  $0.35 In,min$  (1-phase supply). The related setting values, however, cannot be set via DIP/HEX switches.

In the diagram above, look up the transformer rating (horizontal axis) and the operating voltage (vertical axis) and find the operating primary current at the related entry. The background color suggests a matching CT.

Example: The transformer data  $S_n = 1600 \text{ kVA}$ ,  $V_n = 10 \text{ kV}$  guides you to the entry "92" [A], and its background color stands for the **W4** CT. (Depending on your application, this might be a simplification, of course. In ["3.3.2.3 Selection of the CT Transformation Voltage Ratio"](#) some of the criteria are listed that can be considered during the planning phase.)

### 3.3.3 Adapter CTs for 1 A / 5 A

Only the special WIC1-compatible CTs are permitted for the phase current inputs. (See [↳ “WIC1 CTs”](#).) The connection of common CTs - with 1 A or 5 A secondary current - is not permitted.

If the use of standard CTs for 1 A or 5 A is mandatory (for technical or historical reasons) it is possible to connect [special adapter CTs](#) between the standard CTs and the WIC1. These transform the 1 A (or 5 A) secondary rated current into the magnitude that is expected by the WIC1.



The adapter CTs are used instead of the WIC1-CTs. That means they can only be used with device variants WIC1-x**S** ([↳ “2.6.1 Order Form of the Device”](#)). (In other words, they are not compatible with variants WIC1-x**B**.)

Moreover, the adapter CTs are designed such that the WIC1 setting for the (relative) nominal current must be as follows:

- [Field Para / CT] »CT . In,relative« = 1.0.

Only with this setting, a phase current of 1 A (or 5 A), as delivered on the secondary side of the standard CTs, results in the phase current 1.0 *In* measured by the WIC1. Any other setting for »CT . In,relative« results in an incorrect protection functionality.

#### WARNING!



Due to technical constraints with respect to construction, the Adapter CT has a window, just like the feed-through of a standard CT. But it is not permitted to mount an MV / primary current cable through this Adapter CT window!

Ignoring this can result in dangerous voltages at the contacts, and due to wrong measuring values there would not be any effective protection of your equipment.

#### NOTICE!



Please note also these peculiarity, that are inherent to the construction of the Adapter CTs:

- The housing (see [↳ Fig. 15](#)) contains three Adapter CTs, so that all three phase currents are covered. Therefore you need to buy only one unit, see also [↳ “Adapter CTs for 1 A or 5 A”](#).
- There are no test windings. Therefore the test sockets of the WIC1 **cannot** be used with the Adapter CTs.

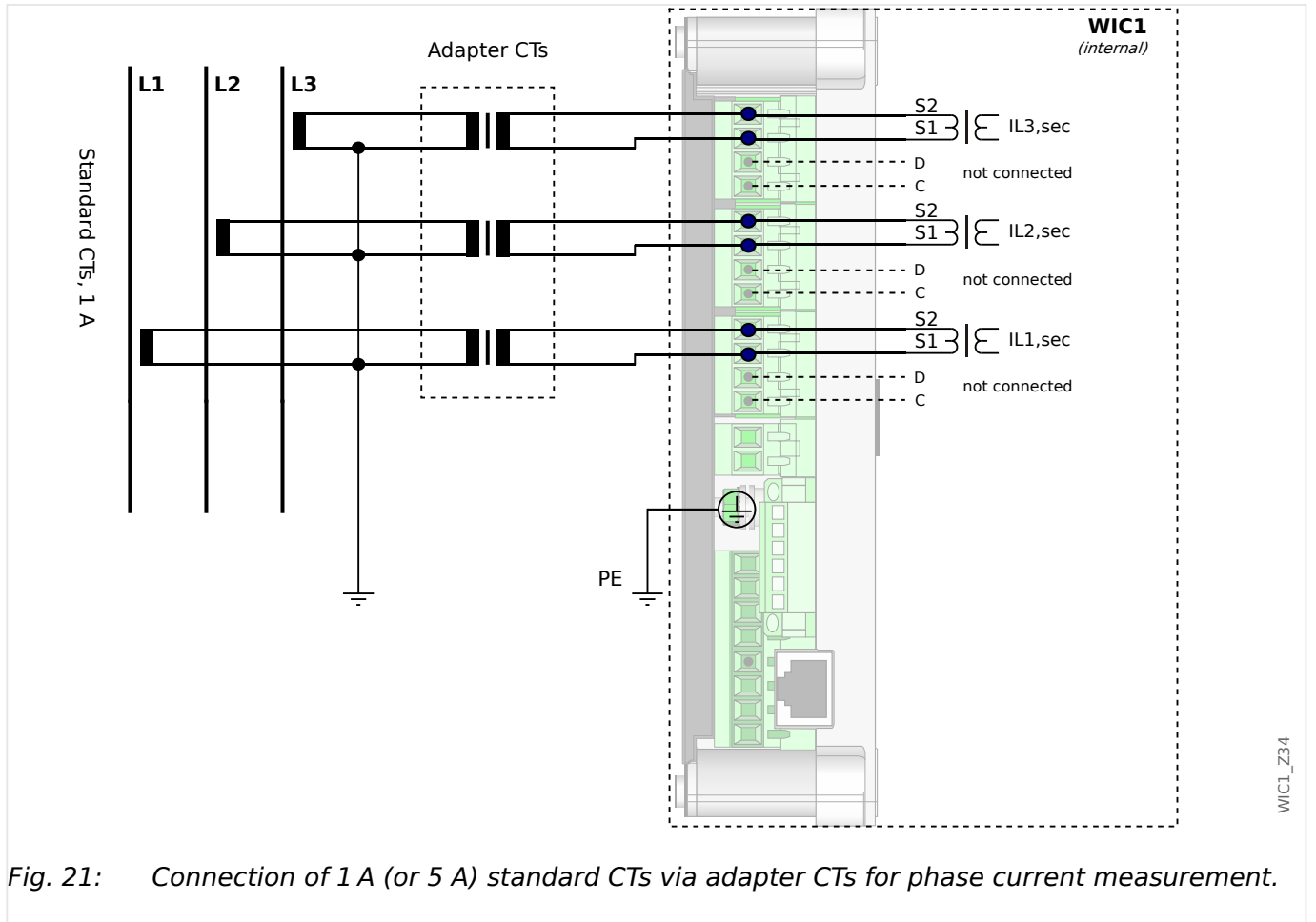

Fig. 21: Connection of 1 A (or 5 A) standard CTs via adapter CTs for phase current measurement.

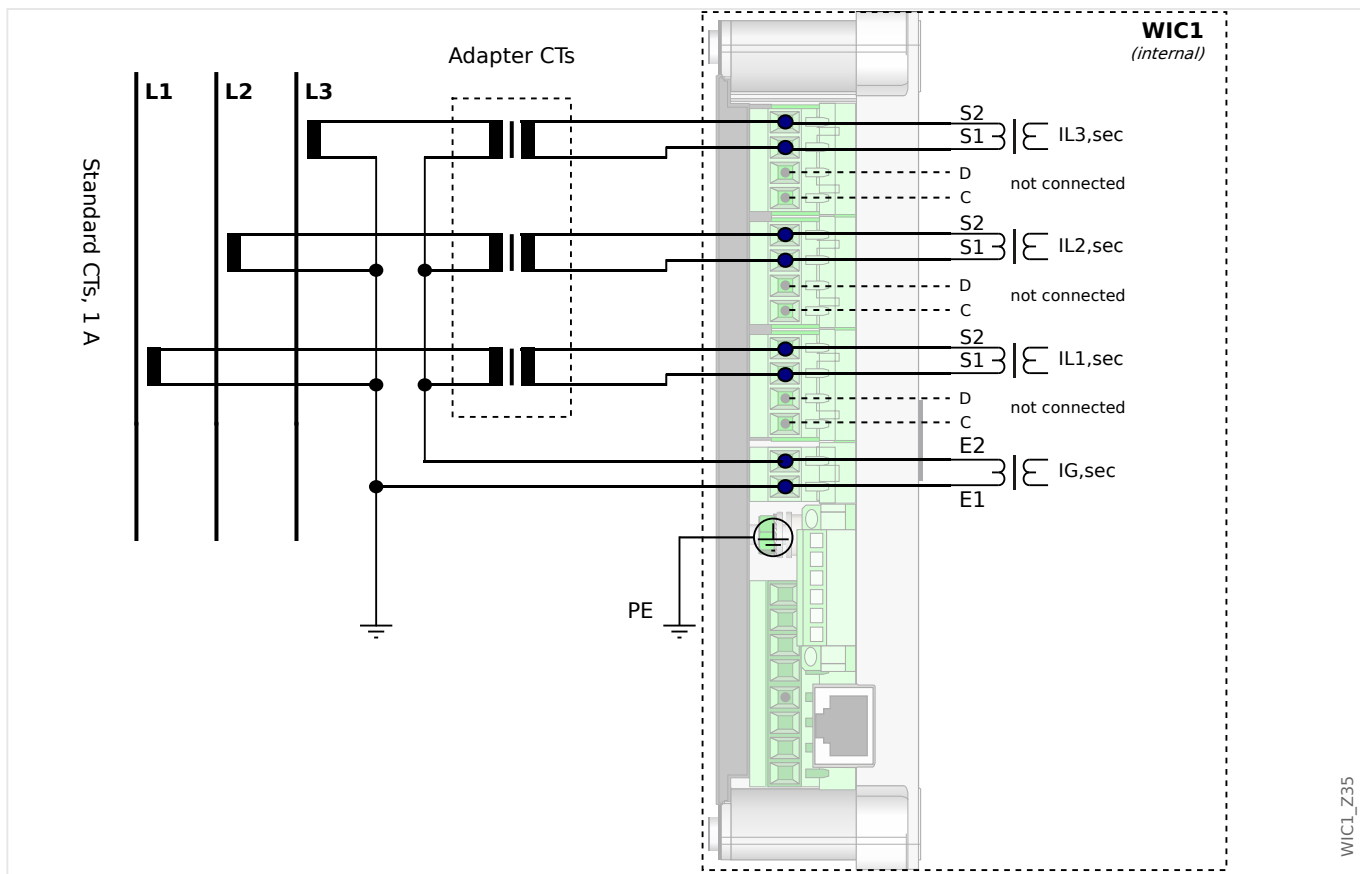

Fig. 22: Connection of 1 A standard CTs with adapter CTs in a Holmgreen circuit.

**WARNING!**



Since the WIC1 has only a 1 A ground current input, the Holmgreen circuit is not available with 5 A CTs.

The standard CTs, however, must fulfill some requirements so that the WIC1 can be safely supplied and the current can be measured with sufficient accuracy.

**3.3.3.1 Requirements for Standard CTs**

The standard CTs must fulfill specific requirements to be used in combination with the Adapter CTs. The following data, however, is very simplified. If it does not suit your application, there is a more detailed version in [“12.3 Requirements for 1 A/5 A Standard CTs with WIC1 Adapter CTs”](#).

The burden power rating of the standard CT has to be multiplied with its Accuracy Limit Factor (ALF). The result has to be above a particular threshold:

1 A Standard CT	5 A Standard CT
$ALF \cdot S_{VA} \geq 10VA$	$ALF \cdot S_{VA} \geq 100VA$

For example, take an xP5 CT for 1 A with 2.5 VA burden rating:

$$ALF \cdot S_{VA} = 5 \cdot 2.5 VA = 12.5 VA \geq 10VA$$

**CAUTION!**



The maximum permitted short-circuit current of the Adapter CT is  $100 \cdot I_r$  for the duration of 1 second. (See also [↪ “10.4.3 Technical Data - Adapter CTs for 1 A, 5 A”.](#))

**1 A Adapter CT**

Additional resistances in the secondary circuit of the standard CT (additional cables, short circuit rails, etc.) must not be higher than  $0.3 \Omega$  ( $0.2 \Omega$  for Holmgreen connection) in this case.

**5 A Adapter CT**

Additional resistances in the secondary circuit of the standard CT (additional cables, short circuit rails, etc.) must not be higher than  $0.1 \Omega$  in this case. (The Holmgreen circuit is not available with 5 A CTs, see also [↪ Chapter 3.3.3.](#))



### 3.4 Phase and Ground Current Measuring Inputs

The WIC1 is provided with current measuring inputs for measuring the phase currents and – for the appropriate variants – one for measuring the earth (ground) current:

- WIC1-x**S**: 3 phase current inputs.

The phase current inputs are designed for the WIC1-compatible CTs, see [↪](#) “2.6.1.3 Order Form of the WIC1-Compatible Current Transformers”.

- WIC1-x**SN**: No ground current measurement. The ground current must therefore be calculated out of the phase currents.
- WIC1-x**SG**: 1 ground current measuring input, that is designed for a CT with secondary current of 1 A.

In addition, there are test inputs available for phase currents and ground current, as dedicated terminals and (internally connected) sockets at the front side of the device. (See diagrams [↪](#) Fig. 23, [↪](#) Fig. 24.) These test inputs can be used for secondary tests during commissioning. (See [↪](#) “8.1.4.2 Wiring Checks”.)

#### DANGER!



The terminal block for connection to the current transformers is not a shorting block. Therefore always short-circuit current transformers before loosening the terminals.

Ignoring this can result in dangerous voltages at the open contacts (up to dozens of kilovolts depending on the CT type).

#### CAUTION!



Only the special WIC1-compatible CTs are permitted for the phase current inputs! The connection of common CTs with secondary currents of 1 A or 5 A is not permitted for the phase current inputs! (An exception is the use of a special adapter CT, see [↪](#) “3.3.3 Adapter CTs for 1 A / 5 A”.)

The ground current input – if available – is designed for a CT with secondary current of 1 A.

The properties of the Current Transformers, in particular the rated CT current  $I_n$ , must also be specified in the settings, see [↪](#) “12.1.3 Setting of the Rated CT current  $I_n$ ”.

The input for earth (ground) current measuring – if available – can be connected to a cable-type current transformer.

The test inputs are convenient for the secondary tests during commissioning: A test current can be fed into the WIC1, without the need to disconnect the cables from the current measuring inputs. See [↪](#) “8.1.4.2 Wiring Checks”.

#### DANGER!



The WIC1 must be grounded/earthed at the correct terminal “PE”, see also [↪](#) “3.3.1 Grounding”.

**CAUTION!**



The measuring winding (terminals S1 and S2, and - if available - S3, S4) of the CTs must not be earthed, otherwise the measurement results are distorted, ensuring in erratic behavior of the WIC1.

**DANGER!**



The current measuring inputs may exclusively be connected to current measuring transformers (with galvanic separation) of the type matching the ordered WIC1 variant.

**DANGER!**



The terminal block for connection to the current transformers is not a shorting block. Therefore always short-circuit current transformers before loosening the terminals.

Ignoring this can result in dangerous voltages at the open contacts (up to dozens of kilovolts depending on the CT type).

**DANGER!**



The WIC1-compatible current transformers are dimensioned for nominal voltages < 1000 V. This means for an application in MV-switchboards (i. e. voltages < 36 kV) that these current transformers may only be used with insulated primary conductors, for example cables, with appropriate insulation resistance against earth. These current transformers are not allowed to be used for non-insulated primary conductors > 1000 V against ground (earth).

In addition, the medium voltage cables, whose phase currents shall be measured via the CTs, must be furnished with a grounded/earthed shielding.

Ignoring this can result in dangerous voltages at the open contacts (up to dozens of kilovolts depending on the CT type).

### 3.4.1 Current Measuring Inputs for WIC1-CTs and Without Ground Current Input

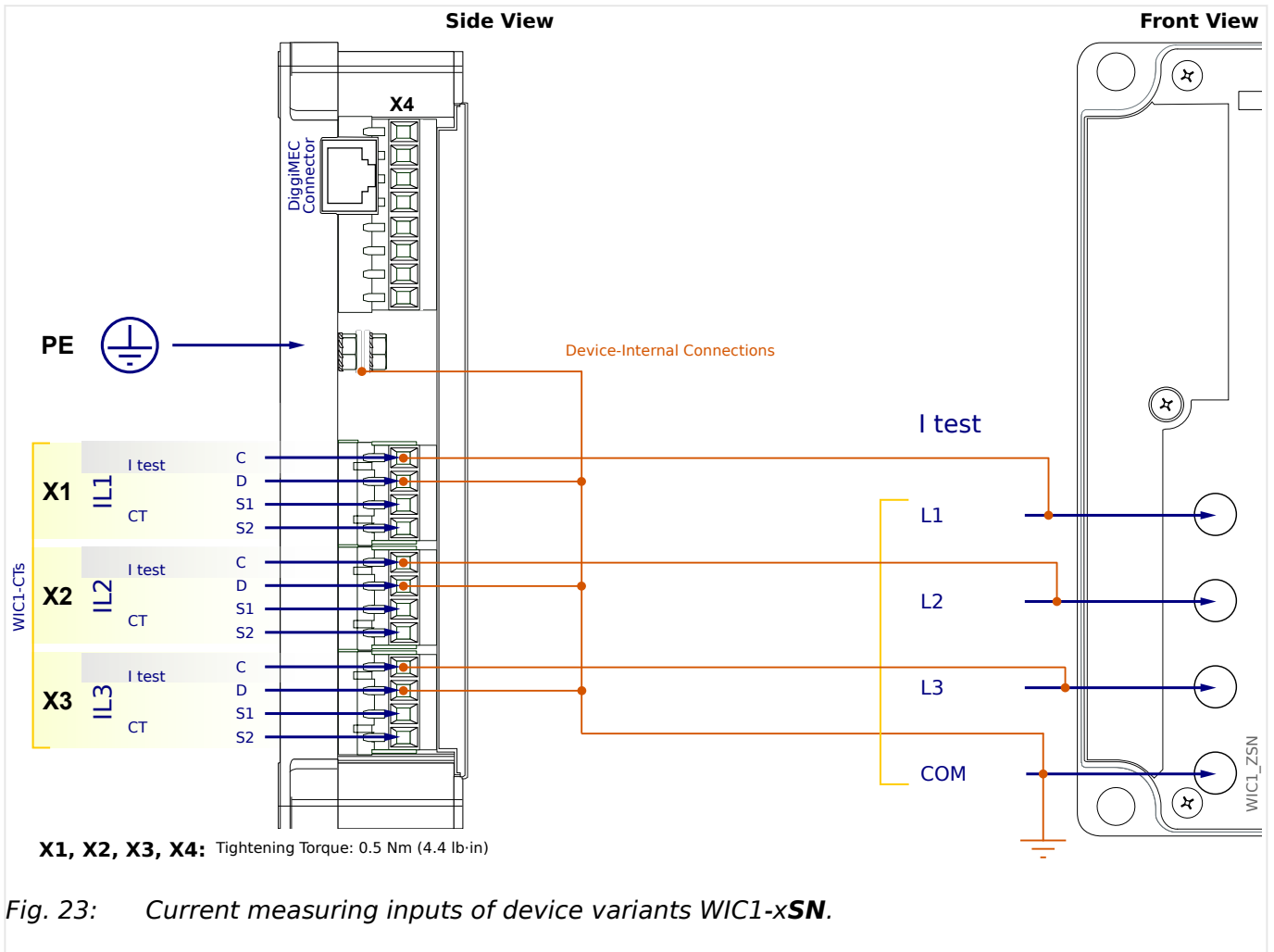
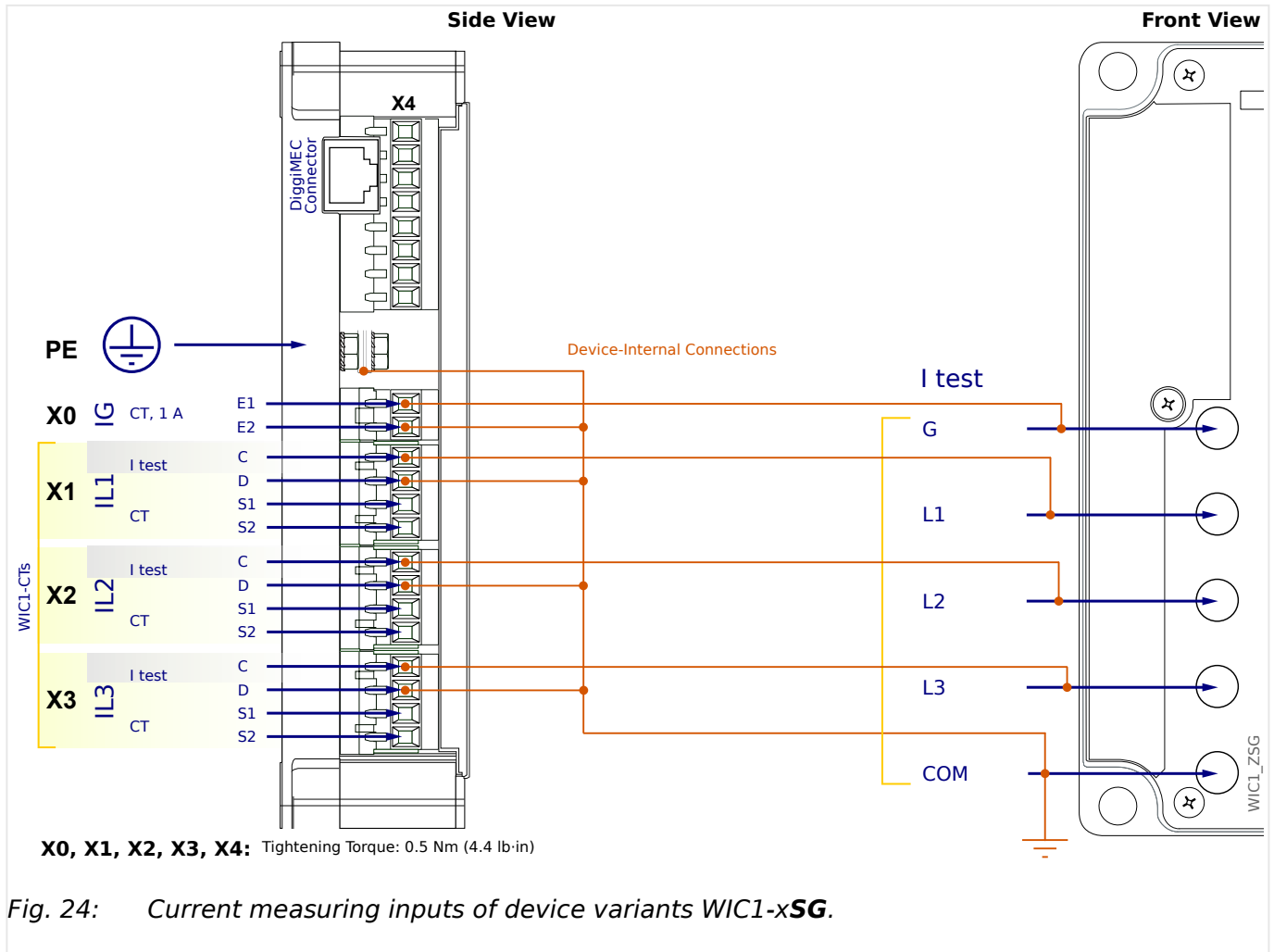

Fig. 23: Current measuring inputs of device variants WIC1-xSN.

### 3.4.2 Current Measuring Inputs for WIC1-CTs With Ground Current Input



### 3.5 Digital Input (only WIC1-1... / WIC1-2... / WIC1-3...)

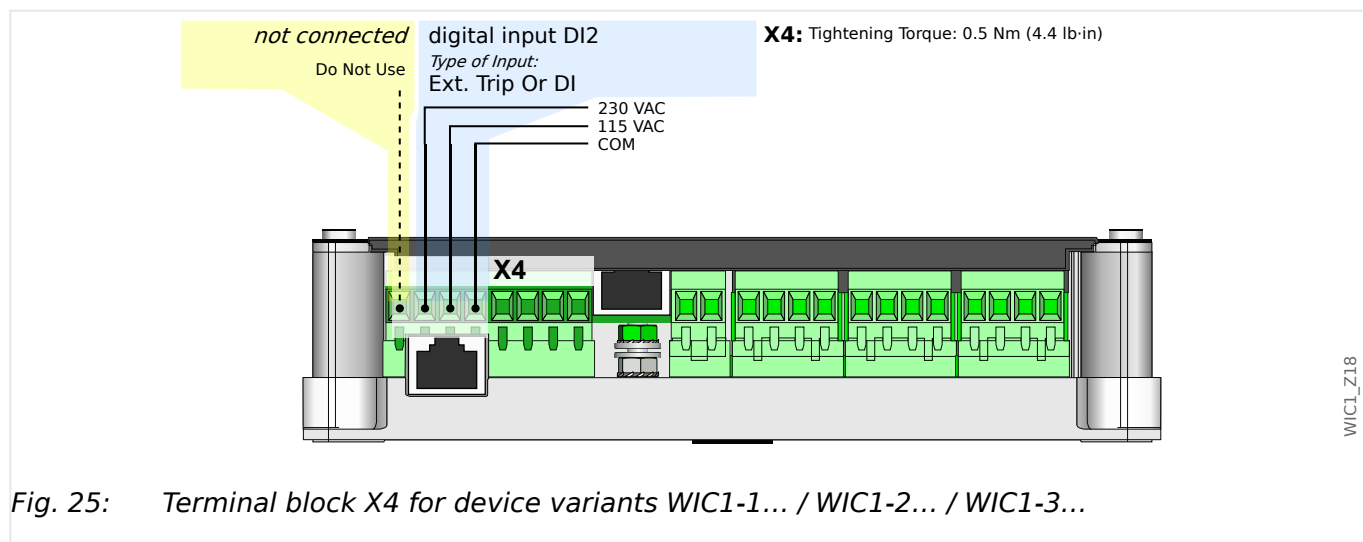

Fig. 25: Terminal block X4 for device variants WIC1-1... / WIC1-2... / WIC1-3...

The “Inputs” terminal block (see also [↳ “3.1 Overview of Elements and Connectors”](#)) **always** features:

- a “COM” common terminal, that serves as the common potential for all other inputs.

Moreover, this terminal block can feature (depending on the [order options](#)) a digital input based on 115 VAC or 230 VAC input signals. (See [↳ “10.1.9 Remote \(External\) Trip Input / Digital Input \(WIC1-1, WIC1-2, WIC1-3\)”](#) for details.)

This digital input is always referred to as **DI2**, when it comes to settings or displaying states. (Note that nonetheless, these device variants do not have a DI1.)

- For device variants WIC1-xxxxx**F**, this input has a fixed function as an external trip signal.

An external trip signal triggers the protection function »ExP«, see [↳ “5.12 ExP - External Protection”](#). Depending on its configuration, »ExP« issues either an alarm message or trips the circuit breaker (via the impulse output, [↳ “Impulse Output for a Trip Coil”](#)).

- For device variants WIC1-xxxxx**C**, this input is configurable.

If the input is used for an external trip together with a cold restart of the WIC1 the resulting tripping time depends on the input voltage. This is due to the recharging time of the capacitors for the trip signal. However, as long as the voltage is within the [specified range](#), the tripping time is  $\leq 0.5$  s. (See also [↳ “10.2.1.8 External Protection”](#).)

#### CAUTION!



It is not allowed to connect any continuous voltage to the 115 VAC or 230 VAC input!

Any continuous voltage can destroy the internal signal transformer.

### 3.6 Additional Power Supply and Digital Inputs (WIC1-4... only)

**CAUTION!**



The Digital Inputs of the WIC1 are not potential-free, but always related to the “COM” terminal (see diagrams).

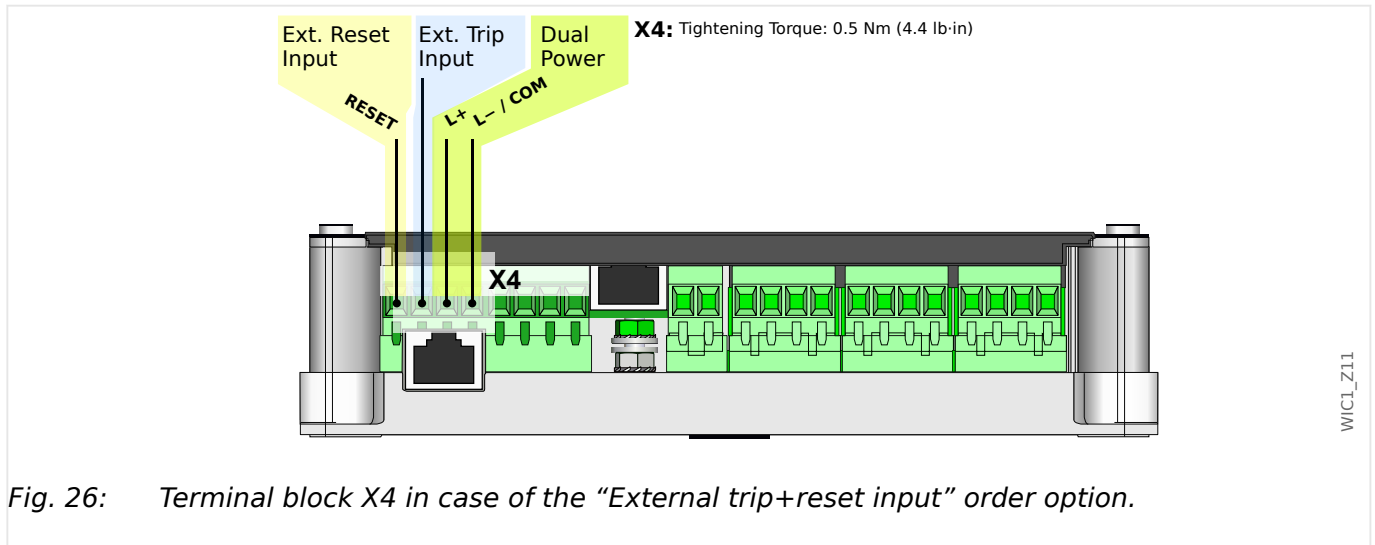

Fig. 26: Terminal block X4 in case of the “External trip+reset input” order option.

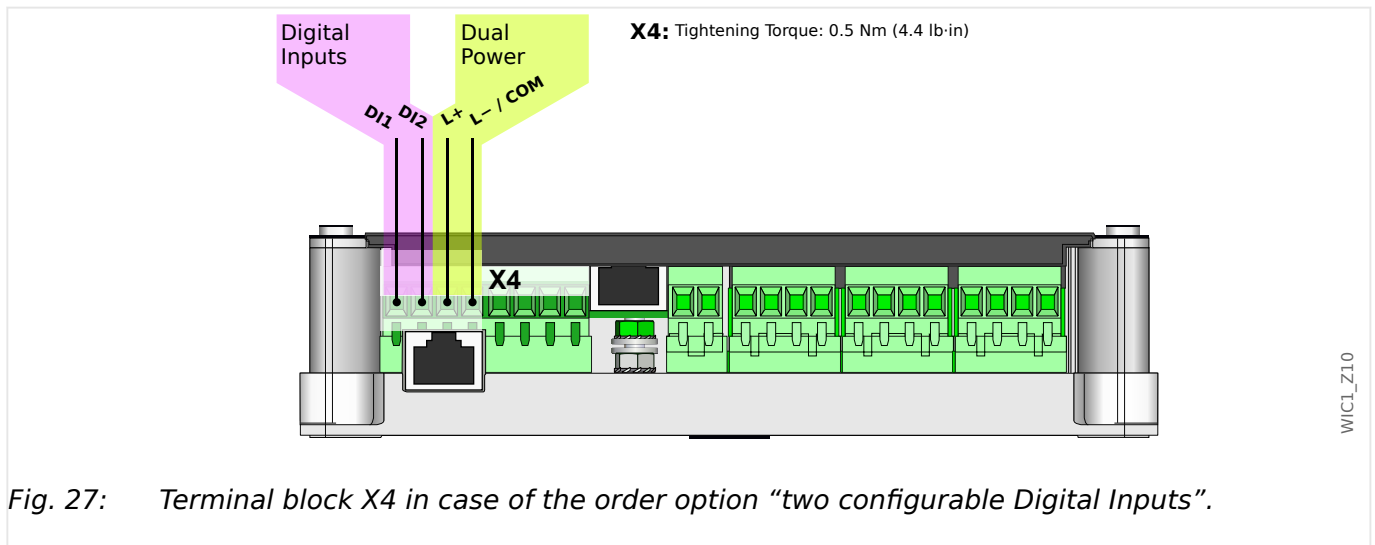

Fig. 27: Terminal block X4 in case of the order option “two configurable Digital Inputs”.

Terminal block X4 (see also [3.1 Overview of Elements and Connectors](#)) **always** features:

- a “COM” common terminal, that serves as the common potential for all other inputs.

Moreover, this terminal block can feature the following, depending on the ordered device variant:

- Inputs for an additional auxiliary power supply unit.
- 2 (grouped) digital inputs. These can be as follows, depending on the ordered device variant:

- Inputs for external trip signal and external reset signal (non-configurable inputs).
- 2 configurable digital inputs.

(For the order options of the WIC1, see [↳ “2.6.1 Order Form of the Device”](#).)

### **Additional Power Supply**

The WIC1 does not require any aux. voltage supply, consequently it can also be used for switchboards without auxiliary power supply. It takes its power supply energy from the CT circuits and provides the tripping pulse energy to the circuit breaker.

However, the WIC1-4 variant with the “Dual Power” order option allows for connecting an additional external power supply.

The dual power source makes the relay independent of the supply via the CTs, so that it can also operate in case of very small phase currents or after a protection trip. The dual-power will make the relay n-1 secure, because the electrical power that the relay requires for operation is taken either from the dual power source or from the CTs.

The permissible voltages for the optional auxiliary supply can be found in [↳ “10.1 Technical Data - WIC1”](#).

### **Digital Inputs**

The WIC1-4 is provided with 2 grouped digital inputs.

For some device variants, the assignment of the digital inputs is fixed to “external reset” and “external trip”.

For the other device variants, the assignment is set to “external reset” and “external trip” by default, but can be changed as described in [↳ “3.9.2 Configuration of the Digital Inputs”](#).

- „External trip“ — By default, an external trip signal triggers the protection function »Exp[1]«, see [↳ “5.12 ExP - External Protection”](#). Depending on its configuration, »Exp[x]« issues either an alarm message or trips the circuit breaker (via the impulse output, [↳ “Impulse Output for a Trip Coil”](#)).
- „External reset“ — An external input signal resets several latched states, see the table in [↳ “2.12 Reset”](#).
- The settings related to the configurable digital inputs are described here: [↳ “3.9.2 Configuration of the Digital Inputs”](#)

#### **WARNING!**



It is not permitted to feed any long-term or continuous voltage into the Digital Inputs.

In other words, it is strongly discouraged to try to supply the WIC1 (for a considerable time) via the Digital Inputs.

If this is ignored the Digital Input can be overloaded, and this can lead to a permanent damage of the WIC1.

### 3.7 Serial Interface RS485 (WIC1-4... only)

**WARNING!**



Ensure the correct tightening torques.

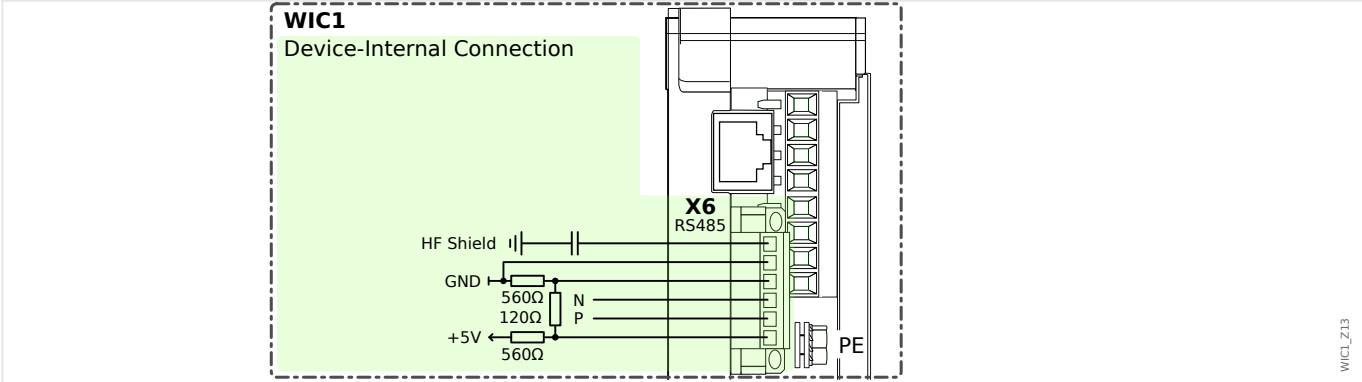
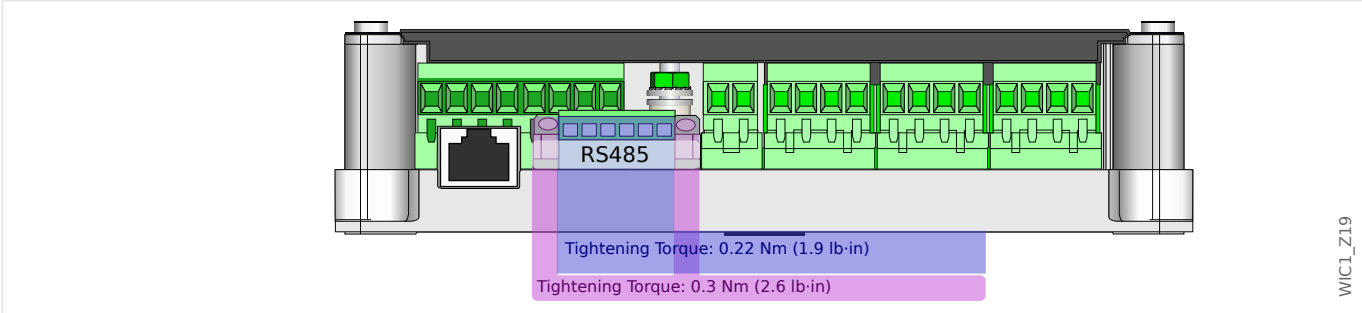



Fig. 28: RS485 Terminals / Electro-mechanical assignment.

A serial RS485 interface may be available depending on the [ordered device type](#).

It can be used for the [Modbus RTU SCADA](#) protocol.

**NOTICE!**



- The RS485 interface is usable only if the WIC1-4 is supplied with an auxiliary voltage. It is switched off in self-supplied operating mode.
- The Modbus® connection cable must be shielded. The shielding has to be fixed at the PE screw.

The communication is halfduplex.



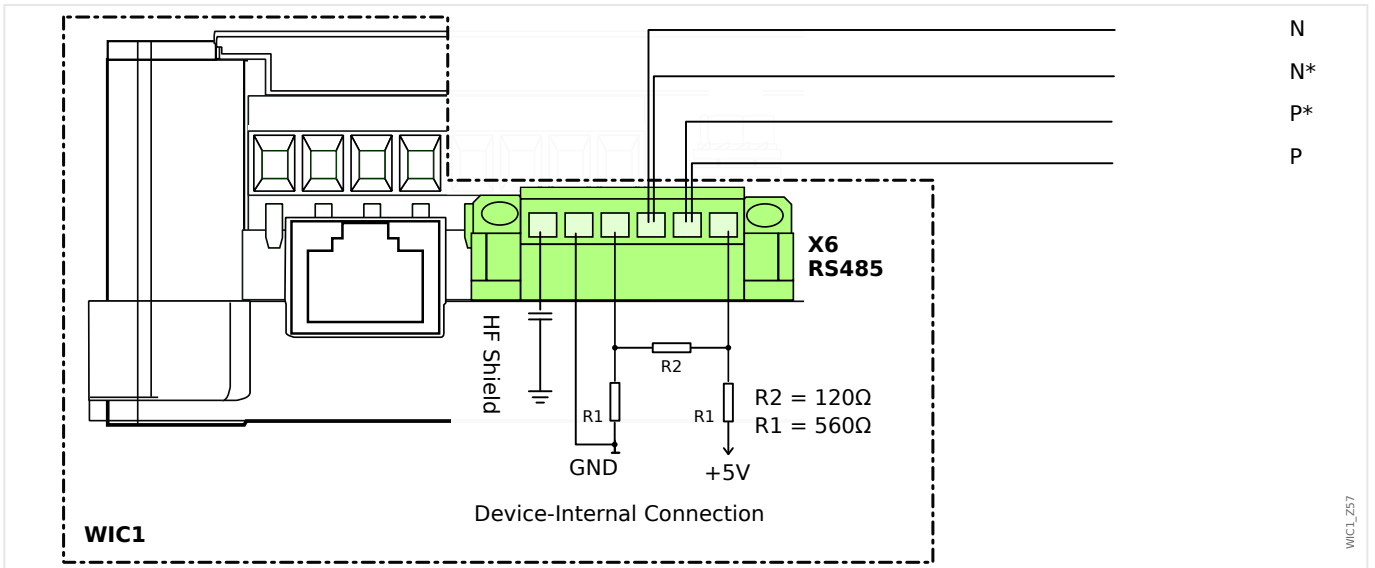

Fig. 29: Wiring example, Device in the middle of the bus.

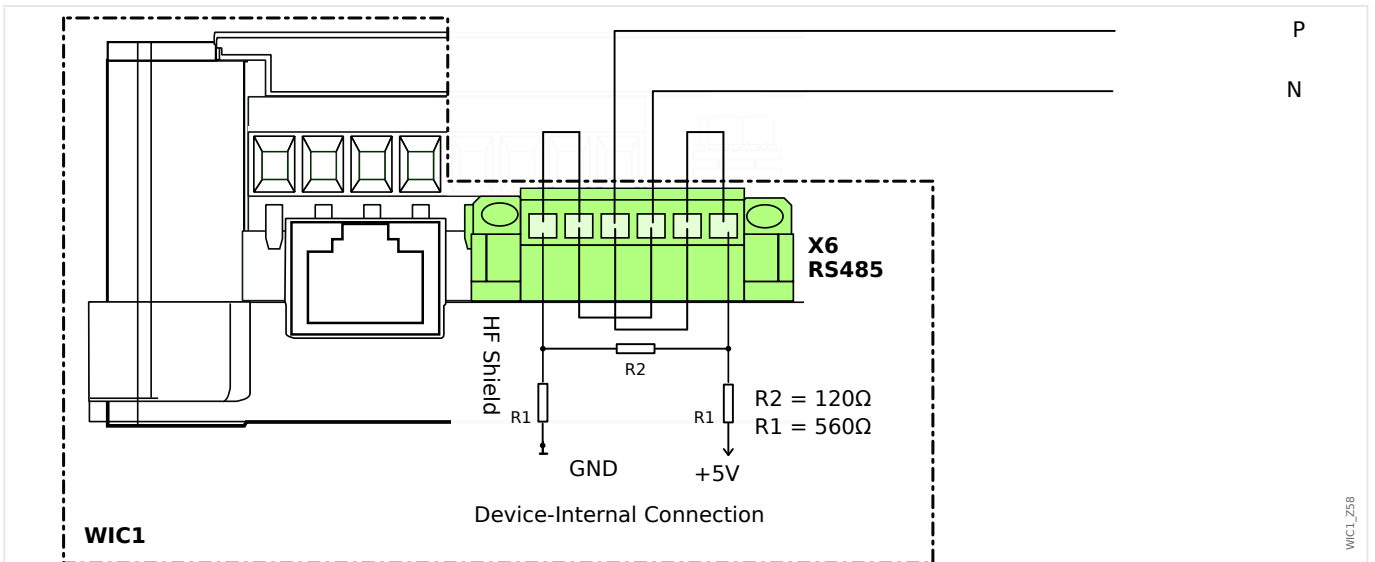
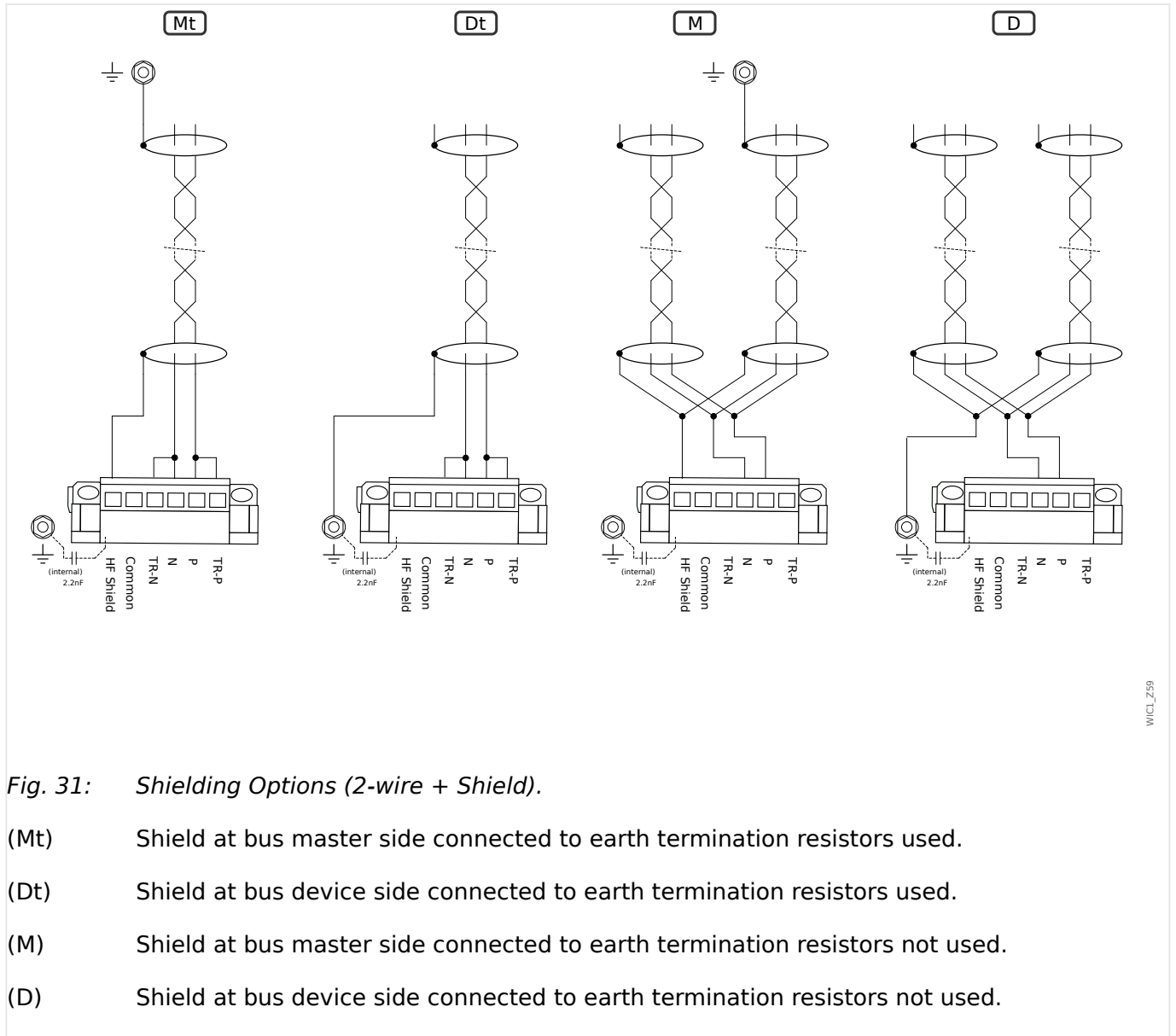

Fig. 30: Wiring example, Device at the end of the bus. (Setting wire jumpers to activate the integrated Terminal Resistor.)

3 Hardware

3.7 Serial Interface RS485 (WIC1-4... only)



WIC1\_59

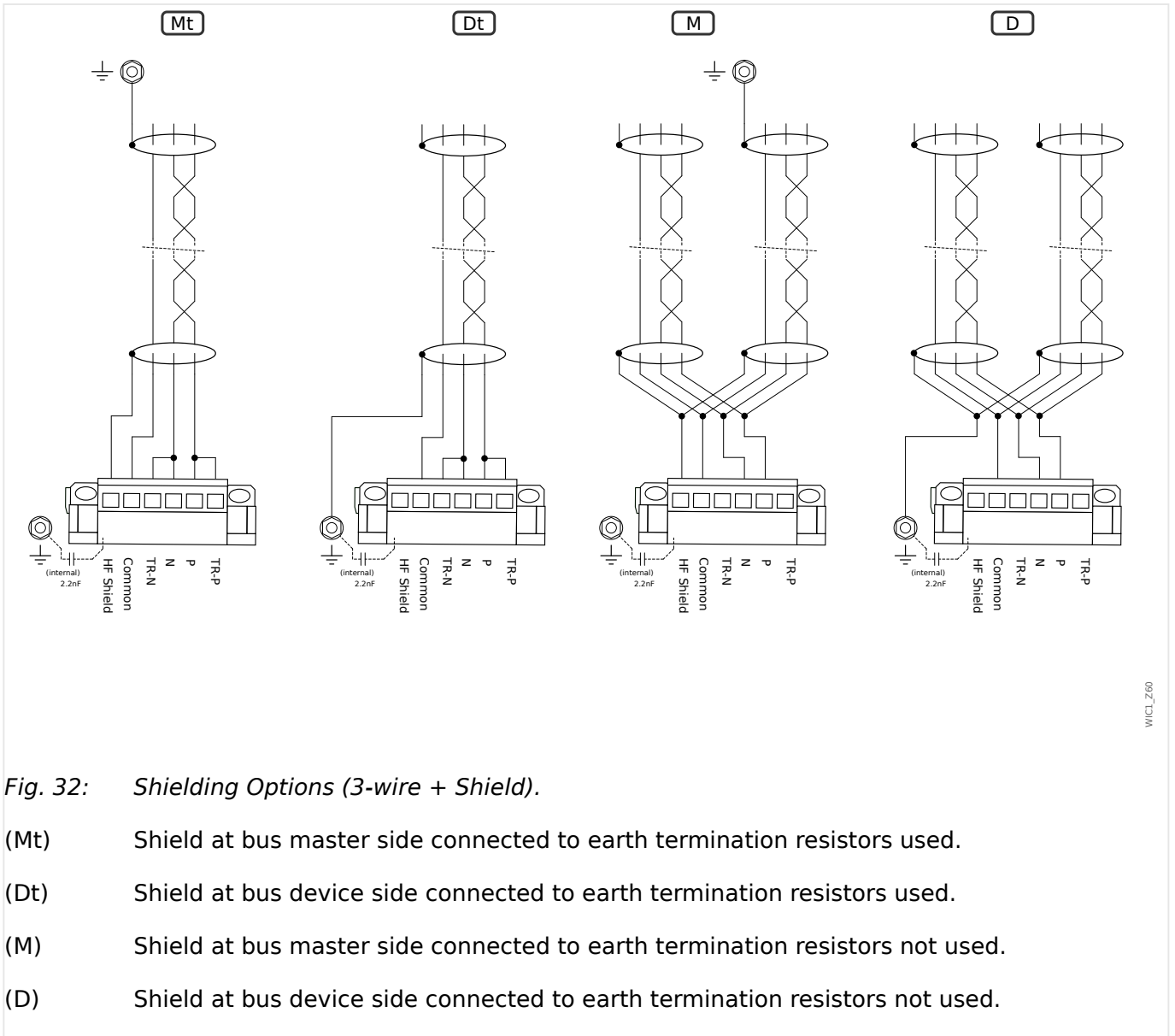

WIC1\_60

### 3.8 Outputs (Trip Coil, Flag Indicator, Relay Output)

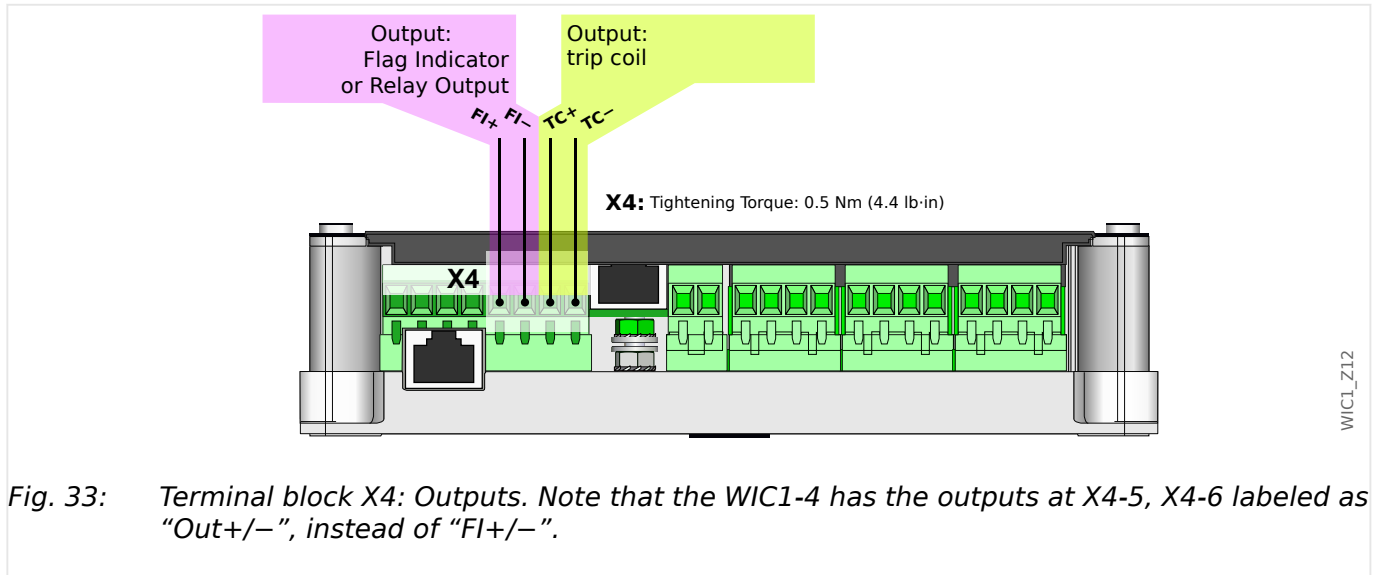

Fig. 33: Terminal block X4: Outputs. Note that the WIC1-4 has the outputs at X4-5, X4-6 labeled as “Out+/-”, instead of “FI+/-”.

Terminal block X4 (see also [“3.1 Overview of Elements and Connectors”](#)) **always** features:

- a pulse output for a low-energy trip coil.

Furthermore, it **can** feature (depending on the [order options](#)):

- an output, that operates as a pulse output for a mechanical flag indicator.

For an externally supplied WIC1-4, this output can also function as a relay output, see [“Relay Output \(WIC1-4\)”](#).

#### CAUTION!



It is not allowed to connect any active voltage to the trip coil output or to the output (flag indicator / relay output).

The two outputs may be connected at the same time to test equipment (e. g. to binary inputs of an Omicron<sup>®</sup> device) only if these two binary inputs do **not** share a common potential. Otherwise this external potential bridge, together with device-internal circuits, can produce incorrect test results.

#### CAUTION!



For a WIC1-4, it is also necessary that the configured operating mode matches the connected hardware!

(For example, it is not permissible to connect a flag indicator and set the operating mode to “Syst. O.K. & Ext.Suppl.”. See also the related Self-Supervision warnings [SW 3](#), [SW 4](#).)

Moreover, the electrical energy that an output relay drains with operating mode “Syst. O.K. & Ext.Suppl.” requires that the WIC1-4 is supplied by an external auxiliary voltage.

### Impulse Output for a Trip Coil

The low-energy trip coil of the circuit breaker is connected to terminals TC+ and TC– of the terminal block X4. The trip energy is provided by a capacitor store integrated in the protection relay. See also [↳ “5.1.1.1 Trip Pulse and WIC1 LEDs”](#).

Length of each trip impulse:	(approx.) 50 ms  The pause between the individual pulses depends on the impedance of the tripping coil and the current level. Pulsing is continued until the protection function’s tripping state drops off.
Trip energy:	$E \geq 0.1 \text{ Ws}$
Voltage:	24 VDC nominal voltage

### Relay Output (WIC1-4)

With the device variant WIC1-4, it is possible via setting parameter [Device Para / WIC1 / Output] »Prot. Out. Mode« to select between two operating modes for the output “Out+/-”:

- = “Impulse Output” — The contacts “Out+/-” function as an impulse output for a flag indicator. This operating mode is fully compatible to the “FI+/-” impulse output of the first generation WIC1, see also [↳ “Impulse Output for a Flag Indicator \(all WIC1 variants\)”](#).
- = “Syst. O.K. & Ext.Suppl.” — The contacts “Out+/-” output a digital signal, so that an external output relay (of a particular type, see [↳ “10.1.8.3 Relay Output \(WIC1-4\)”](#)) can be connected.

The main application for this output relay is its use as a self-supervision contact. For details, see [↳ “3.8.1 Self-Supervision Contact for the WIC1-4”](#).

Remark: The “Syst. O.K. & Ext.Suppl.” operating mode is also available with the “no-output-variants” WIC1-4xxxN. However, for the device variants WIC1-1, WIC1-2, WIC1-3 the operating mode “Impulse Output” is fixed, so that the output can only be used for triggering a flag indicator.

### Impulse Output for a Flag Indicator (all WIC1 variants)

Depending on the [order option](#), the WIC1 can feature an impulse output for a flag indicator.

A flag indicator can be connected to terminals FI+/- (WIC1-4: Out+/-) of the terminal block X4, e. g. for a power-safe signaling of a trip. See also [↳ “3.8.3 Impulse Signal for the Flag Indicator”](#).

Length of each trip impulse:	(approx.) 50 ms  The pause between the individual pulses depends on the impedance of the flag indicator and the current level. Pulsing is continued until the protection function’s tripping state drops off.
Energy:	$\geq 0.01 \text{ Ws}$
Voltage:	24 VDC nominal voltage

### 3 Hardware

#### 3.8 Outputs (Trip Coil, Flag Indicator, Relay Output)

A mechanical flag indicator **WI1-SZ4** or **WI1-SZ5** can visualize a signal, for example a trip signal, in a power-outage-safe manner. (In case of the **WI1-SZ5** this can be done potentially free via two changeover contacts.)

Exception: A **Backup Protection** trip cannot be assigned to a flag indicator output.

### 3.8.1 Self-Supervision Contact for the WIC1-4

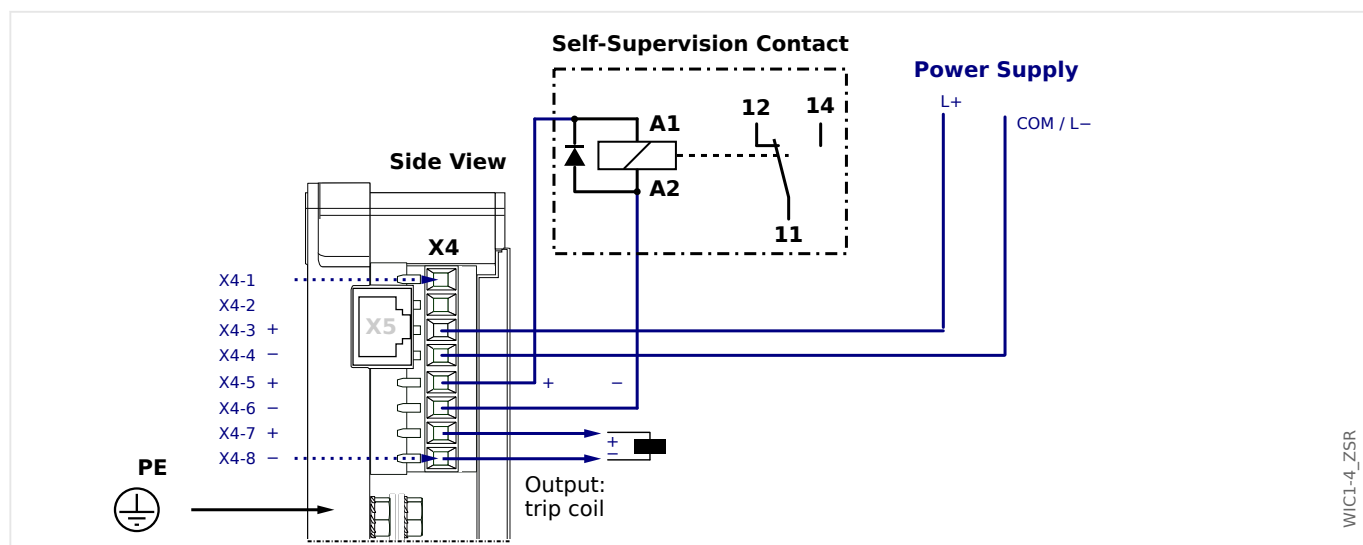

Fig. 34: Connecting an external self-supervision contact.

An externally supplied WIC1-4 allows for connecting an output relay that operates as a “Healthy” / self-supervision contact. (See [diagram](#).)



1. ▷ The output relay must fulfill the specifications in [“10.1.8.3 Relay Output \(WIC1-4\)”](#).
2. ▷ The operating mode of the “Out+/-” output must be set via software parameter as follows:
  - [Device Para / WIC1 / Output] »Prot. Out. Mode« = “Syst. O.K. & Ext.Suppl.”

(There is a special device-internal “Healthy” signal, that is used particularly for this purpose, see also the diagram [Fig. 45](#) in [“5.1.1.1 Trip Pulse and WIC1 LEDs”](#). With the setting above, this signal gets - internally and invisibly - assigned to the “Out+/-” output.)

### 3.8.2 Connecting a Flag Indicator to the WIC1

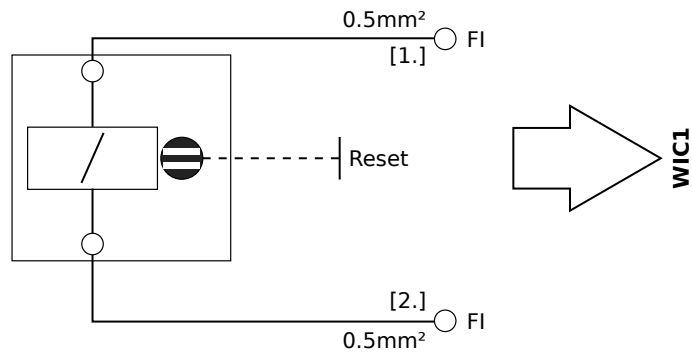

WI1SZ4\_Z01

Fig. 35: Connection diagram for the WI1SZ4 flag indicator.

[1.] black cable,  $\varnothing = 0.5\text{mm}^2$

[2.] black cable,  $\varnothing = 0.5\text{mm}^2$



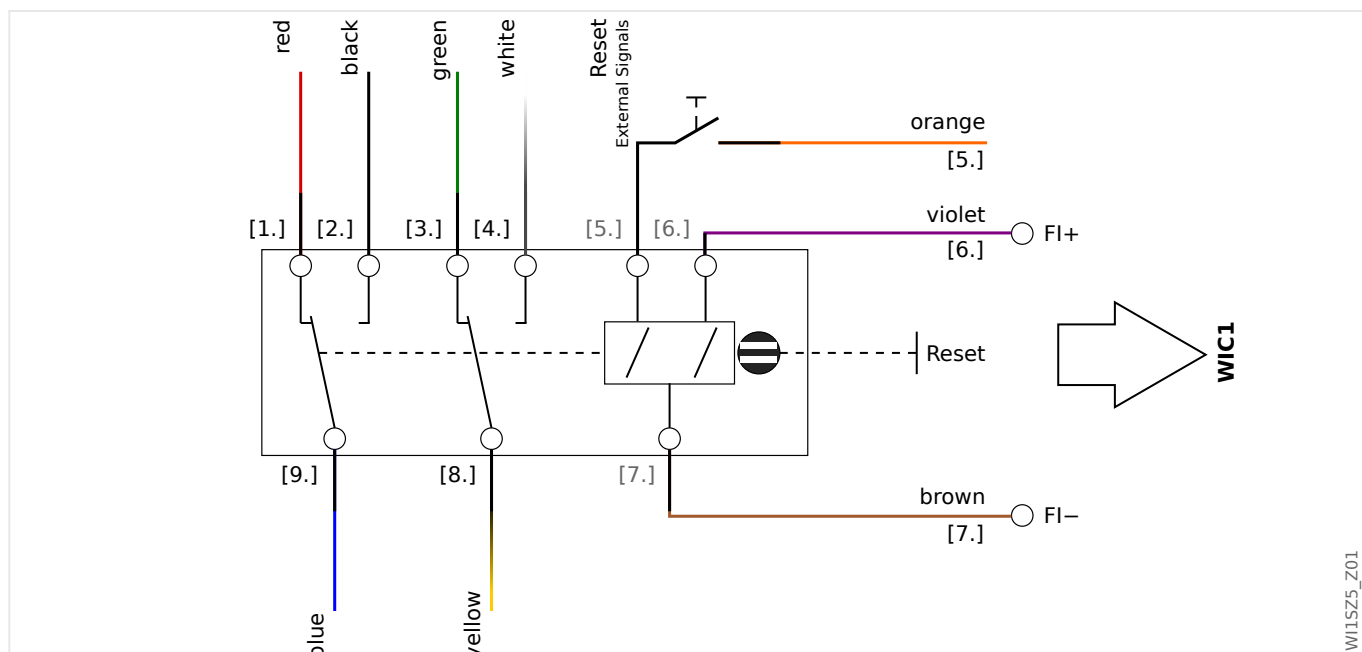

WI1SZ5\_Z01

Fig. 36: Connection diagram for the WI1SZ5 flag indicator.

- [1.] red cable,  $\varnothing = 0.5\text{mm}^2$ : NC contact number 1
- [2.] black cable,  $\varnothing = 0.5\text{mm}^2$ : NO contact number 1
- [3.] green cable,  $\varnothing = 0.5\text{mm}^2$ : NC contact number 2
- [4.] white cable,  $\varnothing = 0.5\text{mm}^2$ : NO contact number 2
- [5.] orange cable,  $\varnothing = 0.25\text{mm}^2$ : reset contact (+)
- [6.] violet cable,  $\varnothing = 0.25\text{mm}^2$ : set contact (+)
- [7.] brown cable,  $\varnothing = 0.25\text{mm}^2$ : ground contact (-)
- [8.] yellow cable,  $\varnothing = 0.5\text{mm}^2$ : Common contact number 2
- [9.] blue cable,  $\varnothing = 0.5\text{mm}^2$ : Common contact number 1

### 3.8.3 Impulse Signal for the Flag Indicator

A flag indicator can be connected to terminals FI+ / FI- (WIC1-4: Out+ / Out-) of the terminal block X4, e.g. for a power-safe signaling of a trip.

The energy is provided by a capacitor store integrated in the WIC1 protection relay. The length of the trip impulse is approx. 50 ms, the pause between the individual pulses depends on the impedance of the flag indicator and the current level. Pulsing is continued until the assigned signal drops off.

Technical Data for the Setting Pulse

- Energy:  $E \approx 0.01 \text{ Ws}$
- Voltage:  $V \approx 24 \text{ VDC}$

**CAUTION!**



It is not allowed to connect any continuous / active voltage to the setting contact or to the reset contact of the flag indicator!

Any continuous voltage can destroy the coil that is built into the flag indicator.

For a WIC1-4, in particular, it is not permissible to connect a flag indicator and set the operating mode of the output to "output relay" (see [↗](#) "Relay Output (WIC1-4)").

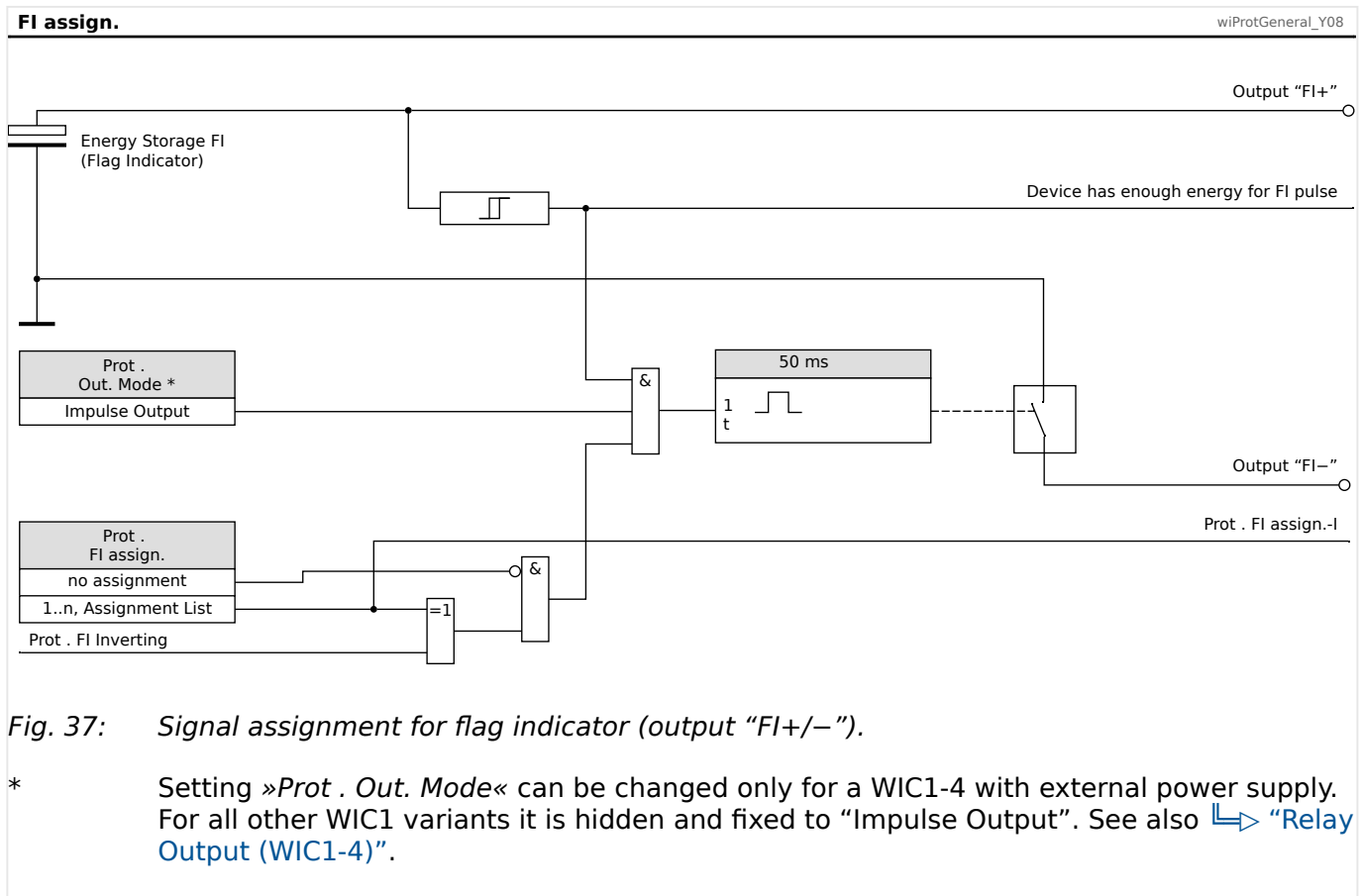
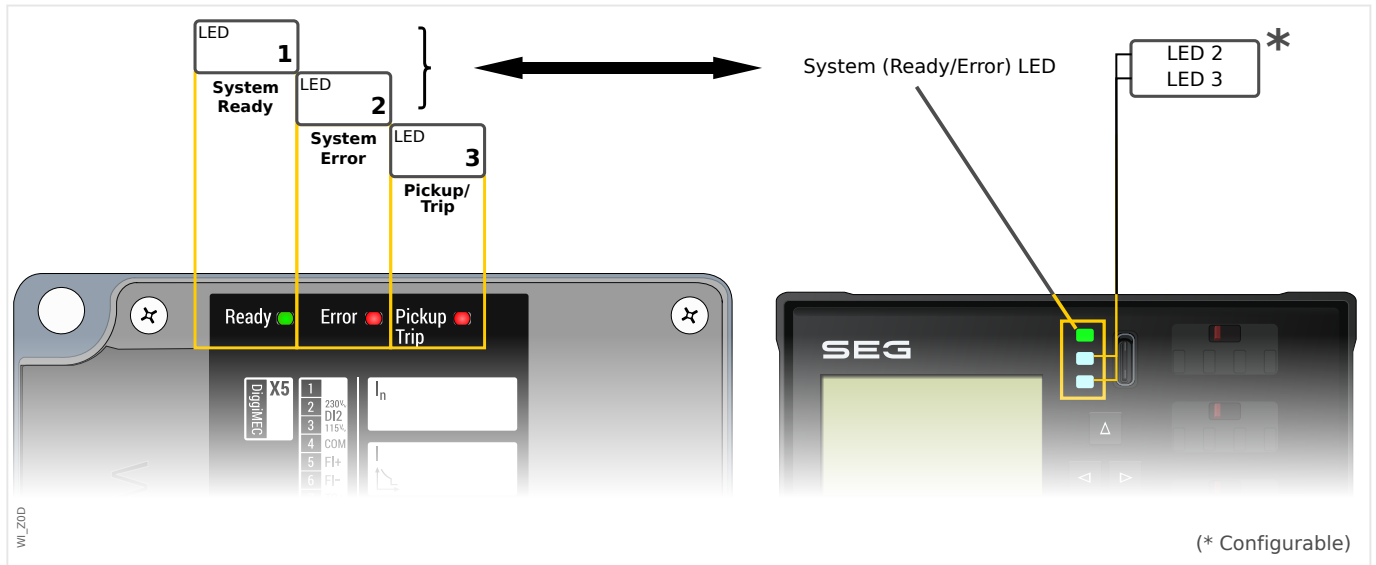

Fig. 37: Signal assignment for flag indicator (output "FI+/-").

\* Setting »Prot. Out. Mode« can be changed only for a WIC1-4 with external power supply. For all other WIC1 variants it is hidden and fixed to "Impulse Output". See also [↗](#) "Relay Output (WIC1-4)".

## 3.9 Input, Output and LED Settings

### 3.9.1 LEDs



#### **WIC1 LEDs**

The WIC1 features one green LED and two red LEDs.

- The green and the first red LEDs are the »System« LEDs and have fixed functionality i.e. cannot be configured. See [↳ “The »System« LED\(s\) - “Ready”, “Error””](#).
- The second red LED, labeled “Pickup / Trip”, indicates a (General) Pickup by blinking, and a (General) Trip by shining constantly red. It cannot be configured. (See also [↳ “5.1.1 General Pickup, General Alarm, General Trip”](#).)

(Of course, in case of a CT-powered WIC1, any LED can be lit only until the breaker has interrupted the power supply.)

#### **DiggiMEC LEDs**

The DiggiMEC features three two-colored (red/green) LEDs. As long as the DiggiMEC is connected to the WIC1 there is the following functionality:

- The first LED corresponds to the two »System« LEDs (i. e. the LEDs “Ready” and “Error”) of the WIC1. See [↳ “The »System« LED\(s\) - “Ready”, “Error””](#).
- The second and third LED can be configured by the user. (See [↳ “3.9.1.2 LED Configuration \(DiggiMEC\)”](#).)

#### **The »System« LED(s) - “Ready”, “Error”**

After booting is complete and all the protection functions are »activated« and there is enough energy for issuing a trip impulse signal, the green »System/Ready« LED lights up.

**NOTICE!**



The green “System/Ready” LED has the fixed (non-configurable) meaning: “Ready to Trip”.

This meaning is more strict than a simple “device is running”. Therefore it is possible (for example if the WIC1 is solely supplied via DiggiMEC-USB) that the WIC1 is running, so that you can configure it and/or read out measuring values, but the “System/Ready” LED is **off** (e. g. because the 5 Volts of a USB interface are o.k. for the operation of the WIC1, but do not suffice for the availability of a ~24 Volts trip pulse).

More details about the »System« LED(s) can be found in the table below, in [↪ “7 Self-Supervision”](#) and in [↪ “11 Troubleshooting”](#).

(WIC1 / DiggiMEC) System-LED: Built-in Signals	WIC1 (Green) System Ready LED	WIC1 (Red) System Error LED	DiggiMEC Two-Colored (Green+Red) System LED
<p>Device not ready (yet). This can also be the case if the software has completely started, but the WIC1 has not (yet) collected enough electrical energy for a trip pulse.</p> <p>Or: The phase currents are not sufficient for the WIC1 so that it is still switched off.</p> <p>Or: The device has been restarted into the “Service Mode” operating mode. In this mode, it is possible to reset all settings to the factory defaults, or to install a firmware update.</p> <p>(Further Infos on the “Service Mode”: <a href="#">↪ “3.10.1.3 Special Keys During Power-on”</a>)</p>	OFF	OFF	OFF
<p>WIC1 has completely booted, the protection functions are running and there is enough electrical energy for a trip pulse.</p>	Constant Green	OFF	Constant Green
<p>Green LED: as above i. e. the WIC1 has collected enough electrical energy for a trip pulse.</p> <p>Blinking red color: The WIC1 has done an automatic restart (due to a device-internal error) and entered a “<b>Protection-Only</b>” operating mode. In this mode, only the protection and supervision functions have been started. (This might hopefully reduce the risk of another error.)</p> <ul style="list-style-type: none"> <li>• In particular, all communication functions are inactive, including connections with DiggiMEC and Smart view.</li> <li>• The DiggiMEC flag indicators / output relays, however, should be functional.</li> <li>• Although the protection functionality is fully active it is recommended to check (and/or replace) the WIC1.</li> </ul>	OFF, or Constant Green	Blinking red	Blinking Red, or Blinking Red ↔ Green
<p>A serious error has been detected, so that the WIC1 could not start as normal, but at least the (hardware-based) <b>backup protection</b> is up and running. (See <a href="#">↪ “5.14 Integrated Backup Phase Overcurrent Protection”</a>.)</p>	OFF	Constant Red, or OFF	<ul style="list-style-type: none"> <li>• Constant Red: if the DiggiMEC is connected to a PC via USB (so that there is an external power supply)</li> <li>• OFF: without supply</li> </ul>

<b>(WIC1 / DiggiMEC) System-LED: Built-in Signals</b>	<b>WIC1 (Green) System Ready LED</b>	<b>WIC1 (Red) System Error LED</b>	<b>DiggiMEC Two-Colored (Green+Red) System LED</b>
<ul style="list-style-type: none"> <li>Since only the backup protection is active the WIC1 needs to be replaced as soon as possible, and you should contact SEG Support.</li> </ul>			

<b>DiggiMEC System-LED: Additional DiggiMEC-specific LED Signals</b>	<b>DiggiMEC Two-Colored (Green+Red) System LED</b>
<p>If the display is <b>not</b> available the DiggiMEC is not supplied with electricity, neither from the WIC1, nor via the USB interface from a connected PC.</p>	OFF
<p>If the display is available (but the LED is OFF):</p> <ul style="list-style-type: none"> <li>The DiggiMEC is properly connected to the WIC1, but the WIC1 reports that protection or tripping is <b>not</b> (yet) available.</li> <li>Or: The WIC1 has been restarted into the “Service Mode” operating mode. In this mode, it is possible to reset all settings to the factory defaults, or to install a WIC1 firmware update.</li> <li>Or: The DiggiMEC has been restarted into the “Service Mode” operating mode. In this mode, it is possible to install a DiggiMEC firmware update.</li> </ul> <p>(Further Infos on the “Service Mode”: <a href="#">↪ “3.10.1.3 Special Keys During Power-on”</a>)</p>	OFF
<p>WIC1 has completely booted, all protection functions are running and there is enough power for a trip pulse.</p> <p>But the power supply by the CTs is not sufficient for the HMI of the DiggiMEC, which therefore stays inactive. (Exception: The blinking LED, and the flag indicators / output relays, which should all be functional).</p>	Blinking Green
<p>If the LED is lit constantly red it means that the DiggiMEC is supplied with electricity via the USB interface from a connected PC, but there is no connection to the WIC1.</p>	Constant Red

### 3.9.1.1 WIC1-LED for "Pickup / TripCmd"

The third LED WIC1 is labeled "Pickup / Trip" and has indeed a double functionality:

- Blinking red — (General) Pickup.  
Constant Red — Trip Command.

Since there is no latching there is no need for a reset of the LED. See also [↳ "5.1.1.1 Trip Pulse and WIC1 LEDs"](#).

### 3.9.1.2 LED Configuration (DiggiMEC)

Apart from the green LED for System OK (that has a fixed function), each LED can be configured via the following parameters within menu branch [Device Para / DiggiMEC / LEDs]:

- »Assigned signals«: The parameters »LED2 assign. 2« and »LED3 assign.« can be used to assign a trigger signal to "LED number x".

**Special case:** Whenever a **trip signal** is assigned to a LEDx, the corresponding **pickup signal** gets signaled as well (via particular blinking patterns), see [↳ "3.9.1.4 Latching of a DiggiMEC-LED with an Assigned Trip Signal"](#).

- »Latching / self-holding function«: If »LED2 latching« / »LED3 latching« is set to anything other than "No latching", the state that is set by the trigger signal is permanently stored. (For details see [↳ "3.9.1.3 Latching of the DiggiMEC LEDs"](#).)

With the setting "No latching", the LED always adopts the state of the assigned signal.

- »LED2 Color« / »LED3 Color«: This defines an "active" color, or a pair of "active + inactive" colors. The LED lights up in this "active" color if the assigned trigger signal is active, and it can light up in the other ("inactive") color if the trigger signal is inactive. Available setting values are:
  - „Red“ - The "active" color is red. (No "inactive" color, i. e. the LED is off when the assigned signal is inactive.)
  - „Green“ - The "active" color is green. (No "inactive" color.)
  - „Green / Red“ - The "active" color is red, and the "inactive" color is green.



An LED test is always also executed together with the reset: All LEDs flash in red color for (approx.) a second, then flash in green color for (approx.) a second.

### 3.9.1.3 Latching of the DiggiMEC LEDs

After the assigned signal has become active a latched LED keeps its state until it is acknowledged, or some automatic reset occurs.

A latched LED gets reset only in any of the following cases and only after the assigned trigger signal has dropped out.

The following latching modes are settable via »LED2 latching« / »LED3 latching«:

- “No latching” - No latching, the status always follows the status of the assigned signal.
- “With latching” - With latching, i.e. the state remains active once the the assigned signal has become active. (After the assigned signal has dropped off the state can be reset by the device.)

A reset is then possible via the Direct Control [Operation / Reset] »Rst. LEDs, Fls«, see also [↪ “2.12 Reset”](#).

- „Latch. w. Auto-Reset“ - latching with automatic reset, see also [↪ “2.12.1 Automatic Reset”](#).

A latched LED state “survives” a complete power-off, i. e. the state is stored in a permanent part of the memory. With the next restart, the LED light up again (or continues its [blinking/flashing](#)).

### 3.9.1.4 Latching of a DiggiMEC-LED with an Assigned Trip Signal

**Special case:** Whenever a **trip signal** is assigned to a LEDx, the corresponding **pickup signal** gets assigned as well, with the following behavior:

- When the corresponding pickup signal occurs, the LEDx starts blinking.

With latching, this continues until a reset is done or until the assigned trip signal occurs. (Reset: See [↳](#) “2.12 Reset”.)

- When the assigned trip signal occurs, the LEDx is lit.

With latching, this continues until a reset is done. (Reset: See [↳](#) “2.12 Reset”.)

- Moreover, there is the following additional behavior with latching:

When a pickup - without a trip - occurs and drops off again, the LEDx starts flashing (with flashing pattern OFF : ON ≈ 10 : 1).

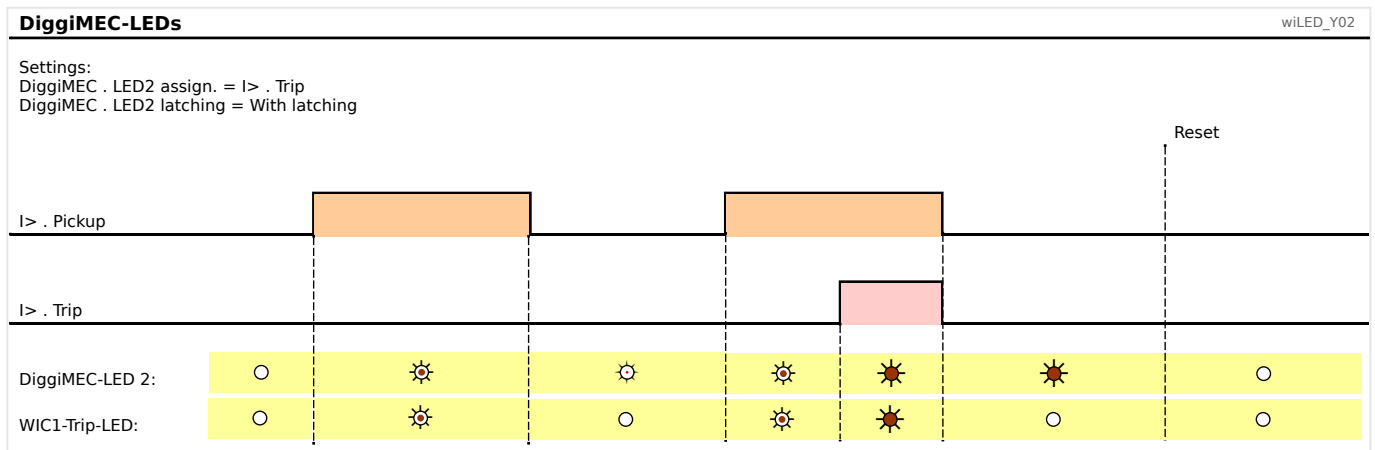
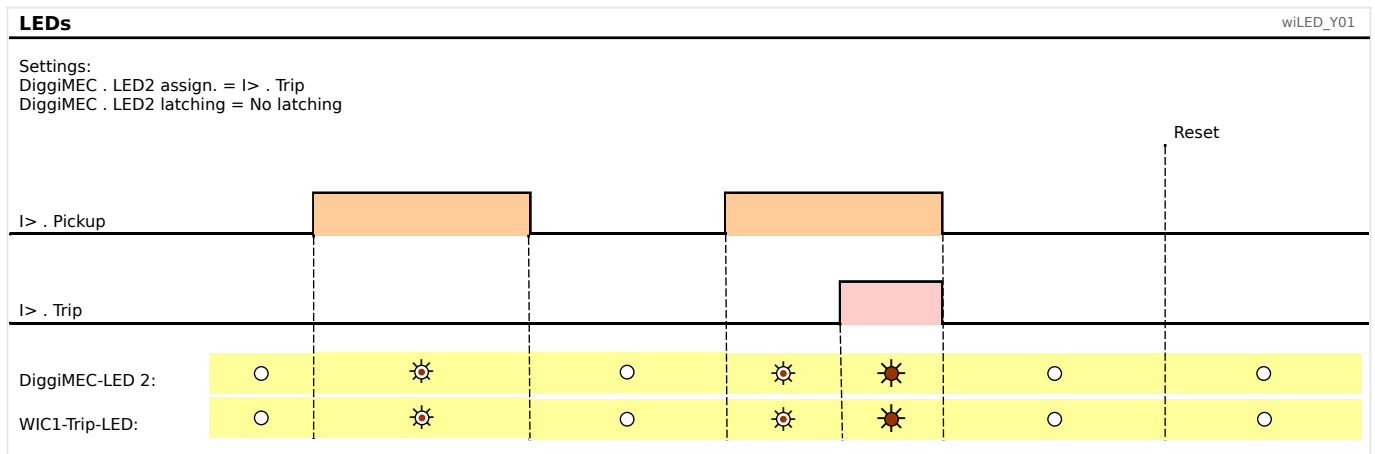



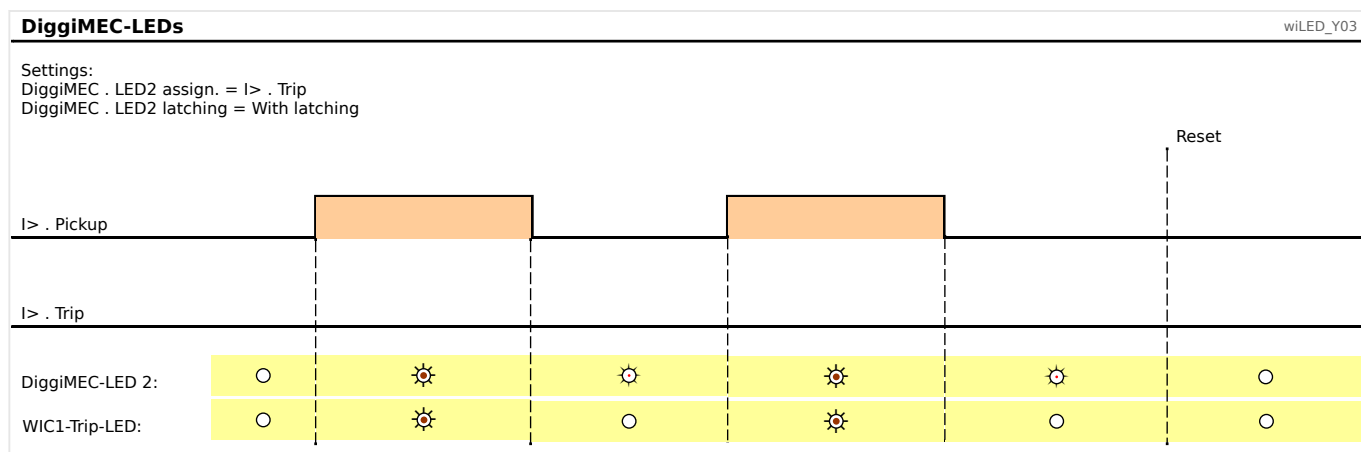

## Symbols

○	The LED is OFF.
☀	The LED is flashing (i. e. is blinking with an OFF : ON pattern of 10 : 1).
☀	The LED is blinking.
☀	The LED is lit continuously.

(Even though the diagrams are showing the settings for LED 2 this is only an example, of course. The analogous settings can also be made for LED 3, resulting in the same signal flow.)

The WIC1 Pickup / Trip LED is shown only for completeness and for comparison: In fact, the WIC1 Pickup / Trip LED does not support any latching.

## 3.9.2 Configuration of the Digital Inputs

Note that not all WIC1 variants feature configurable Digital Inputs. Please check the [order options](#).

Some WIC1 variants feature Digital Inputs. These can have a fixed assignment or can be freely configurable, depending on the order options.

- WIC1-1, WIC1-2, WIC1-3 — There is one Digital Input, that can be triggered by either 115 VAC or 230 VAC. (Each of these two input voltages has its own wiring terminals.)

For technical reasons, this digital input is always referred to as **DI2**.

See also [↳ “3.5 Digital Input \(only WIC1-1... / WIC1-2... / WIC1-3...\)”](#).

- WIC1-4 — There are two Digital Inputs, DI1 and DI2. There is a choice out of several voltages for their triggering input.

See also [↳ “3.6 Additional Power Supply and Digital Inputs \(WIC1-4... only\)”](#).

Independent of the device variant, it is necessary to set the nominal input voltage for the Digital Input(s):

- [Device Para / WIC1 / Digital Inputs] »*Nom voltage*« — The available select options depend on the device variant.

Note that some debouncing is performed for each digital input based on a fixed, device-internal algorithm.

### 3.9.3 Date and Time

The WIC1 lacks a real-time clock. This is an intended construction aspect, because a real-time clock would have required a buffer battery and even communication protocols for time synchronization. The WIC1, however, has been designed to operate in a remote station for years without special maintenance (like exchanging a battery).

Instead of an absolute timestamp, the WIC1 stores the operating time in all entries of the [Fault Recorder](#) and [System Recorder](#). This is the operating time since the last restart, and in addition to this, also the current value of the restart counter is stored.

If there is a connection to DiggiMEC (or Smart view), this operating time (plus restart counter) can be seen at [Operation / Time]. But of course, changing these values is not possible.

### 3.10 DiggIMEC® - Nano HMI with Flag Indicators and Output Relays

The DiggIMEC® is a remote HMI to be used in connection with a WIC1 (generation 2) protection relay. (It cannot be used with the predecessor WIC1.)



DiggIMEC® is a registered trademark. For the sake of readability, most chapters of this User Manual omit the “®” designation. This, however, does not mean that the term “DiggIMEC” can be used without any restrictions.

An overview of the elements and connectors can be found here: [↗ “3.10.1 Navigation - Operation”](#), and here: [↗ “3.10.2 DiggIMEC Connectors”](#)

Information about the LEDs and their configuration is here: [↗ “3.9.1 LEDs”](#)

#### Connection of the DiggIMEC

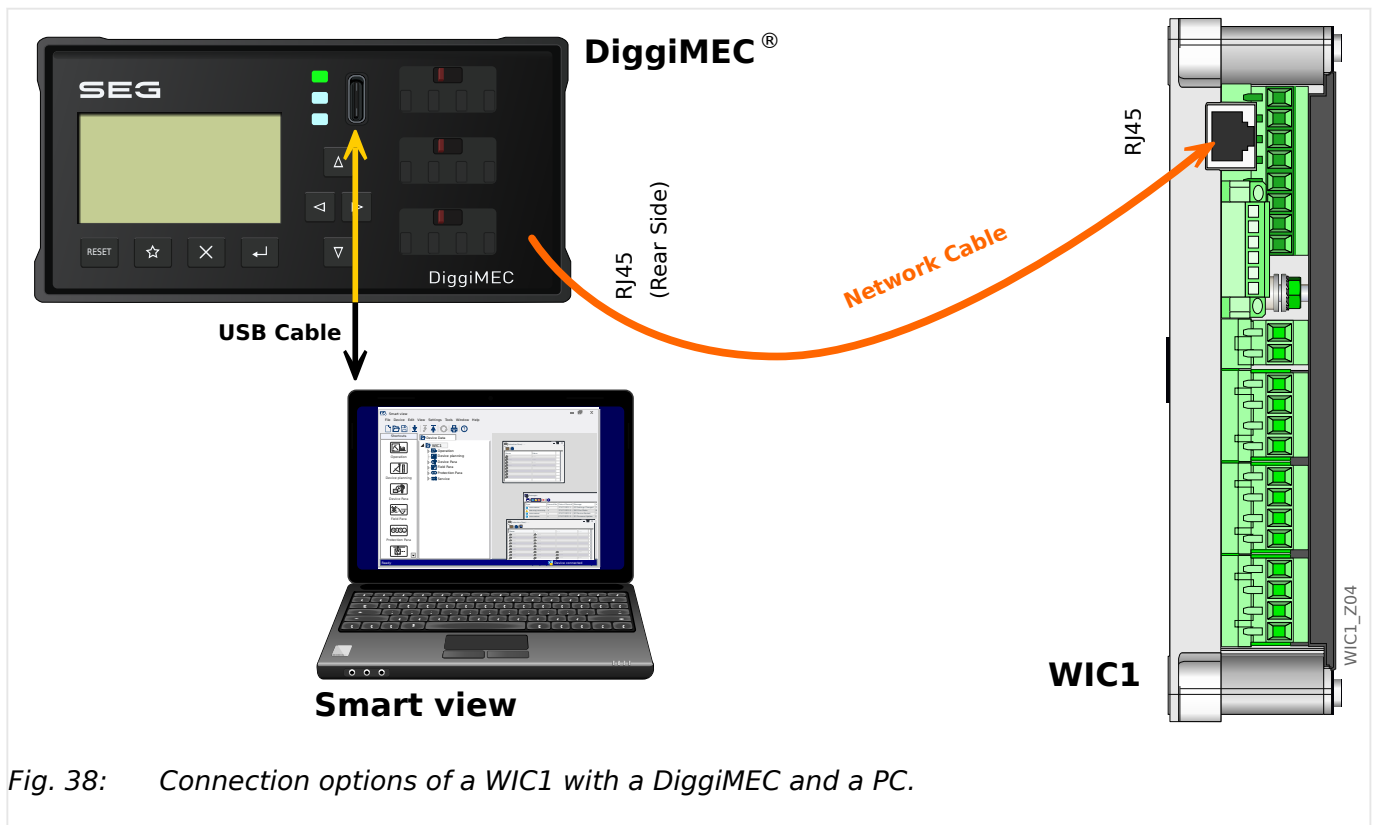

Fig. 38: Connection options of a WIC1 with a DiggIMEC and a PC.

The **WIC1** can be (optionally) connected to the interface device **DiggIMEC**, which adds an LCD display, keys and one or three flag indicators. Each flag indicator is mechanically related to a bistable output relay.

The **DiggIMEC** can be connected to a Windows PC, so that the parameter setting and evaluation software *Smart view* can be used to configure the WIC1 and to retrieve measurement values and fault data from it. Moreover, the WIC1 can trigger the flag indicators / output relays.

**CAUTION!**

Use an Ethernet cable CAT 3 (or better) with shielding for the connection between WIC1 and DiggiMEC. **Crossover cables must not be used!**

Make sure that the connection cable between WIC1 and DiggiMEC is mounted according to all regulations! Respect the manufacturer's specifications about permissible bending radii, and prevent defects by appropriate means such as cable conduits, e. g. if the cable needs to be bent around sharp corners.

A defective cable might impair the internal voltage of the WIC1 and DiggiMEC, and this might affect the capability of the device to operate a trip coil and outputs.

**NOTICE!**

The **DiggiMEC** is always usable only with a connected **WIC1** (independent of whether there is any supply via the USB interface of the DiggiMEC).

### 3.10.1 Navigation - Operation

The following illustration shows the elements on the DiggiMEC front:

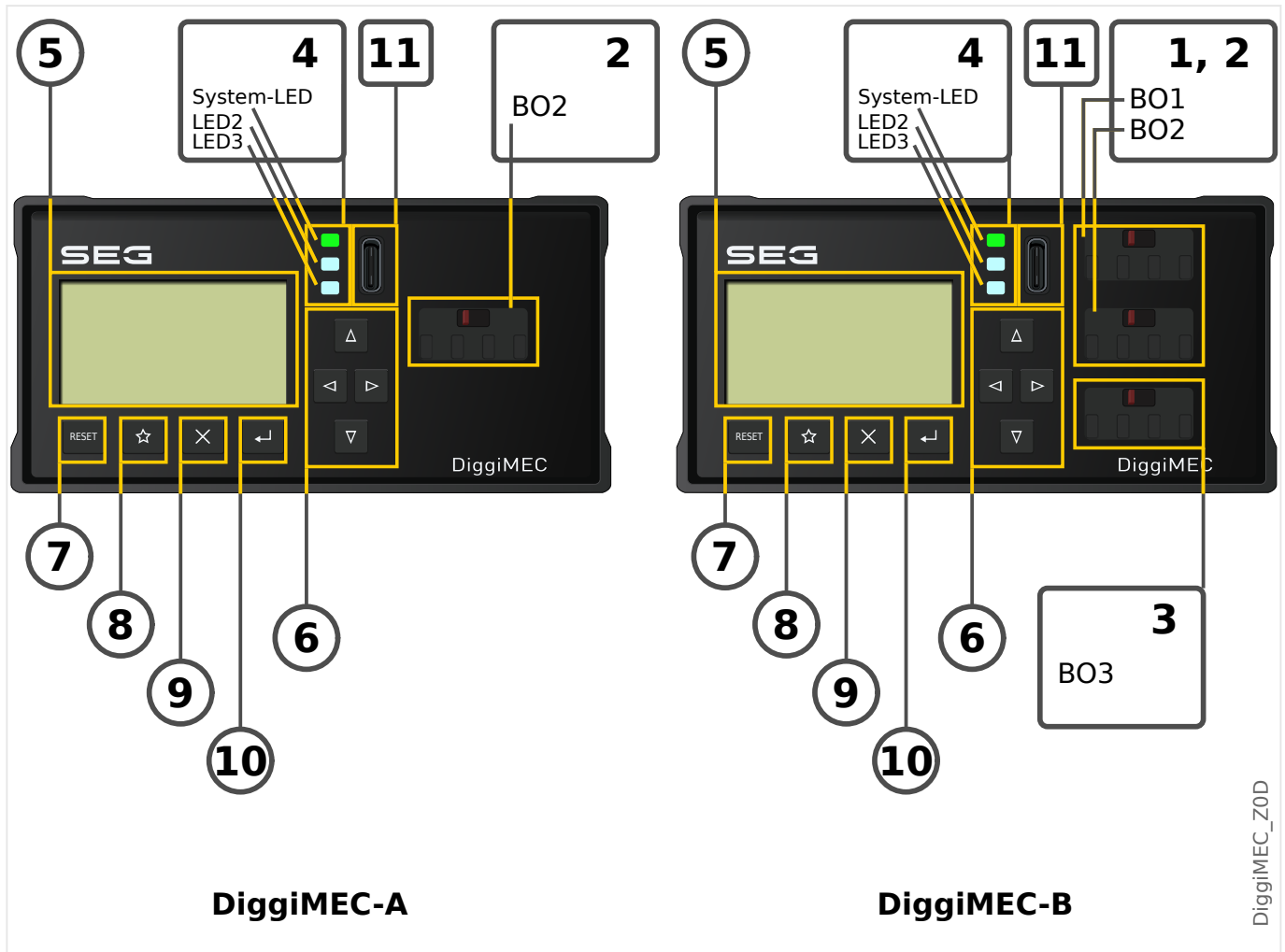

#### 3.10.1.1 Front Panel Parts

##### **(1), (2), (3) Output Relays / Flag Indicators**

Each flag indicator is mechanically connected with a bistable output relay.

**(1), (2)** The flag indicators BO1, BO2 have one “Form A” (normally open) contact each.

**(3)** The flag indicator BO3 has a “Form C” (changeover) contact.

- The device variant DiggiMEC-A has only one bistable output relay BO2.
- The device variant DiggiMEC-B has three bistable output relays BO1, BO2, BO3.

See also [↪ “3.10.2 DiggiMEC Connectors”](#).

##### **(4) LEDs**

The DiggiMEC features three two-colored (red+green) LEDs. The first (upper) »System« LED has fixed functionality and (roughly) corresponds to the WIC1-LEDs »READY« and »ERROR«.

The »System« LED is constantly green when everything works OK. This means, in particular:

- The connection to the WIC1 has been established.
- The WIC1 has successfully started all protection functions.
- The WIC1 has stored sufficient electrical energy to issue a trip impulse.

See also [↪](#) “3.9.1 LEDs”. In case of problems consult [↪](#) “11 Troubleshooting”.

The other two LEDs are programmable. This means they can be assigned with WIC1-signals, so that they can inform you about operational states, system data or other WIC1 particulars.

Various signals can be freely allocated to LEDs out of an »assignment list«. (The available signals can be found in the WIC1 Reference Manual.)

### **(5) Display**

Via the display you can check operational data and edit parameters (of the connected WIC1).

### **(6) ... (10) Keys**

The keys usually react on a short key-press at the moment when the key is released. Exceptions are the Repeat-functionality of ▲ »Up« und ▼ »Down« and the [Special Keys During Power-on](#).



After some time without any keystroke the backlight of the display goes off. Note that then, while the display backlight is off, the first keystroke does nothing but illuminating the display (i. e. the normal key function is ignored).

### **(6) Navigation Keys**

The functions of the keys “◀” (Left), “▶” (Right), “▲” (Up), “▼” (Down) are contextual.

- ◀ In general, the "Left" key is used to go one step back. You can leave a submenu. You go back to the previous page of the menu tree.
- ▶ In general, the "Right" key is used to enter the currently selected submenu.
- ▲ In general, the "Up" key is used to scroll upwards. You go to the prior menu point/one parameter up by scrolling upwards.
- ▼ In general, the "Down" key is used to scroll downwards. You go to the next menu point/one parameter down by scrolling downwards.

The ▲ »Up« und ▼ »Down« keys have a Repeat-functionality. If you hold the keys pressed for some time, the key-stroke gets automatically repeated again and again. This allows for quickly browsing through a long list.

### **(7) »Reset« Key**

A key-press resets latched signals (including latched LEDs, flag indicators and the Fault Display screen).

See [↪](#) “2.12 Reset” for details.



An LED test is always also executed together with the reset: All LEDs flash in red color for (approx.) a second, then flash in green color for (approx.) a second.

### **(8) »★« Key**

The “Favorites” key allows for an immediate access to often used menu branches. See [↩➤](#) “3.10.1.2 Favoriten-Taste »★«” for details.

### **(9) »X« Key**

The “Cancel” key aborts parameter changes.

### **(10) »↵« Key**

The »↵« (»Enter«) key can be used to select new parameter values out of a selection list or value setting dialog. In any other dialogs the »Enter« key is used to store prepared parameter changes: By pressing the »Enter« key once the parameter changes are temporarily stored. These settings are marked by an asterisk symbol (“\*”) on the display, they have not been transferred to the WIC1 yet and are therefore not effective yet. If the »Enter« key is pressed again, those changes are stored definitely.

### **(11) USB Interface (Smart view Connection)**

Connection to the PC software *Smart view* can be done via this USB-C interface.

Moreover, this is a sufficient power supply for DiggiMEC and WIC1, in case the WIC1 is not supplied via the CTs or any auxiliary power (WIC1-4 only).



### 3.10.1.2 Favoriten-Taste »★«

The “Favorites” key »★« allows for an immediate access to often used menu branches.

For the current Release, there is a fixed list of entries. (It is planned to allow for individual choices in a later Release.)

The diagram illustrates the SEG device interface. At the top left, the 'SEG' logo is displayed. Below it, a screen titled 'Favorites' shows a star icon and the text 'Favorite F1'. Below the screen, there are four physical buttons: 'RESET', a star icon, an 'X' icon, and a left arrow icon. A hand icon is shown pressing the star icon, labeled with a circled '1'. To the right of the screen, four function keys are listed with arrows pointing to the screen:

- F1 [Operation / Measured Values / Current ]
- F2 [Operation / Recorders / Fault rec]
- F3 [Operation / Reset]
- F4 [Operation / Self-Supervision / Messages]

Below these function keys, three navigation steps are shown with hand icons:

- (1) Pressing the star icon on the physical keypad.
- (2) Pressing the up arrow (▲) and down arrow (▼) keys to navigate.
- (3) Pressing the left arrow (◀) key to leave the Favorites menu.

DiggiMEC\_Z09

- (1) Press “★” (several times) to call the Favorites one after the other.
- (2) Afterwards, you can navigate as usual (with “▲” and “▼”) and/or enter a details screen (by pressing “▶”).
- (3) Leave the Favorites menu by pressing “◀”.

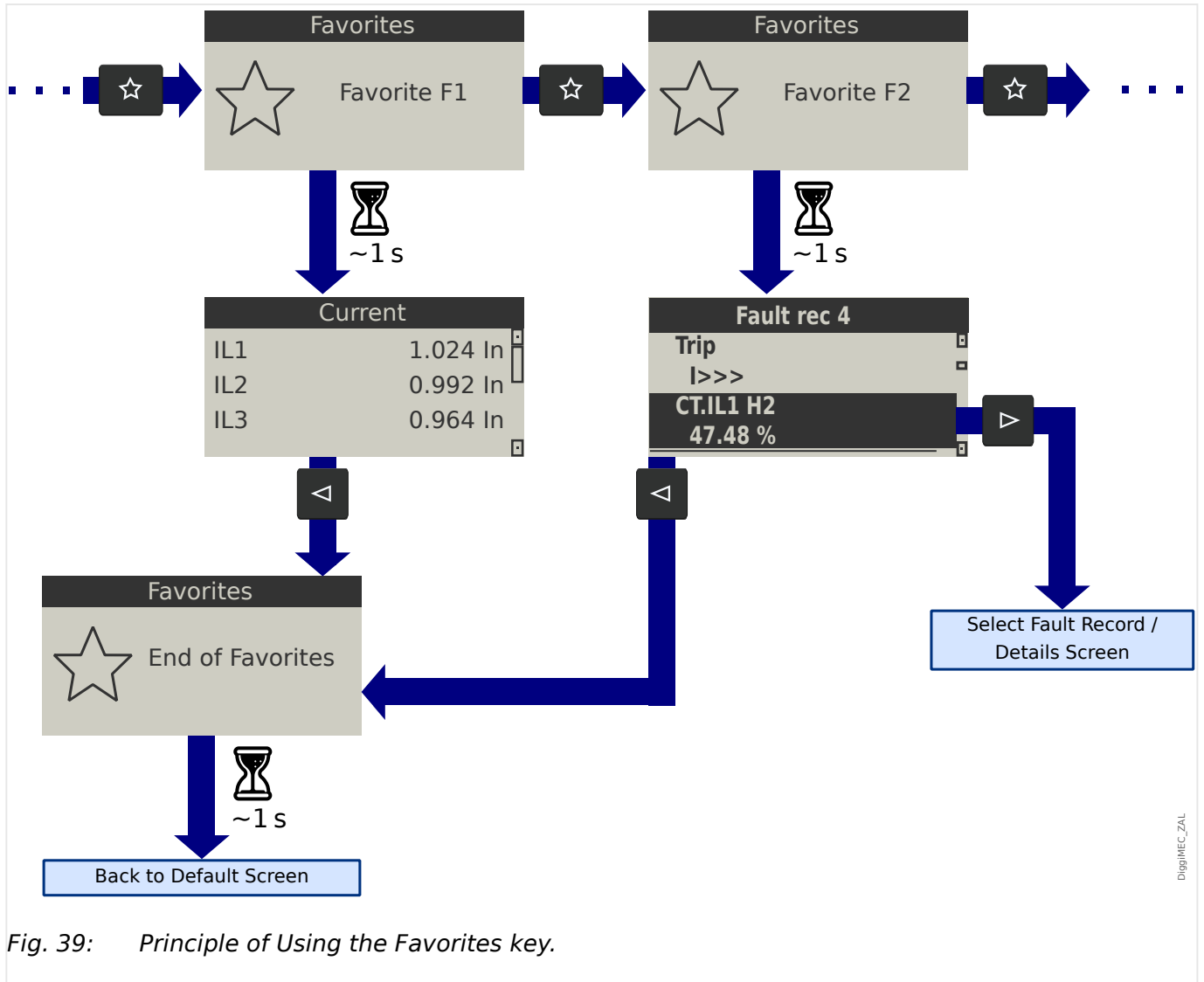

Fig. 39: Principle of Using the Favorites key.

### 3.10.1.3 Special Keys During Power-on

Some keys have a special functionality when being pressed during the power-on / boot process.

- **»⇐« during power-on** - After a confirmation dialog, the DiggiMEC enters a special "Service Mode". This operating mode allows for installing a new firmware on the DiggiMEC.
- **»Reset« during power-on** - After a confirmation dialog, the WIC1 enters a special "Service Mode". This operating mode allows for installing a new firmware on the WIC1.
- **»X« during power-on** - After a confirmation dialog, the WIC1 resets all settings to the respective factory default.

This is the same functionality as the Direct Control [Service / General] »Factory Reset«, see [↳ "2.13 Reset to Factory Defaults"](#).

#### WARNING!



As long as the WIC1 is running in „Service Mode“, your equipment is protected only by the Backup protection, not by the user settings.

This means that the Backup Protection of the WIC1, especially the WIC1-xxxxxx**1** ("Backup Protection trip as soon as possible") variant, might output a trip pulse. Therefore it is strictly recommended to always enter the „Service Mode“ only with the breaker opened (or disconnected).

### 3.10.1.4 Menu Structure

The menu structure offers the following top-level menu entries. You enter a menu branch with the »►« key. The keys »▲« and »▼« let you navigate to the previous or next one. The key »◀« leaves a menu branch so that you go to the previous or to the super-ordinated view.

A complete documentation of all WIC1 menu branches, parameters, direct commands and values in tabular form can be found in a separat document, the “WIC1 Reference Manual”.

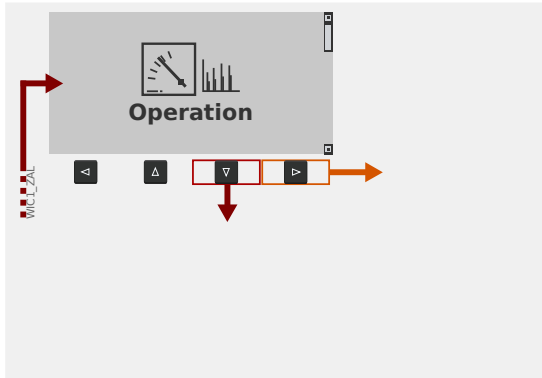
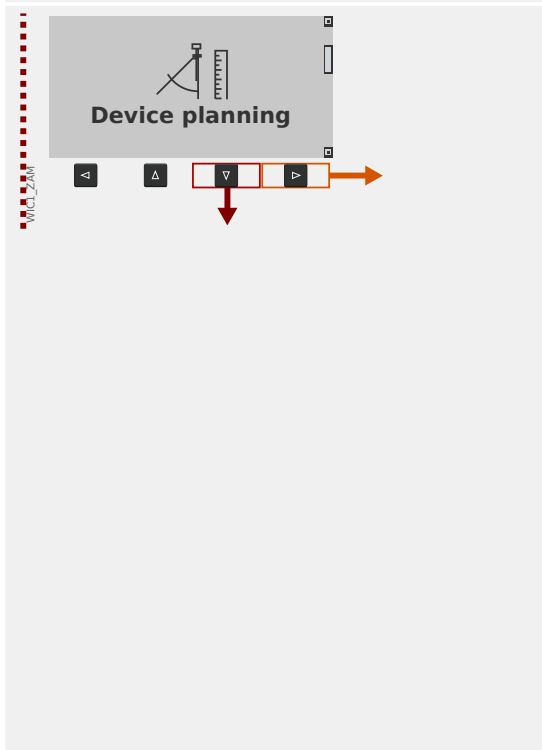
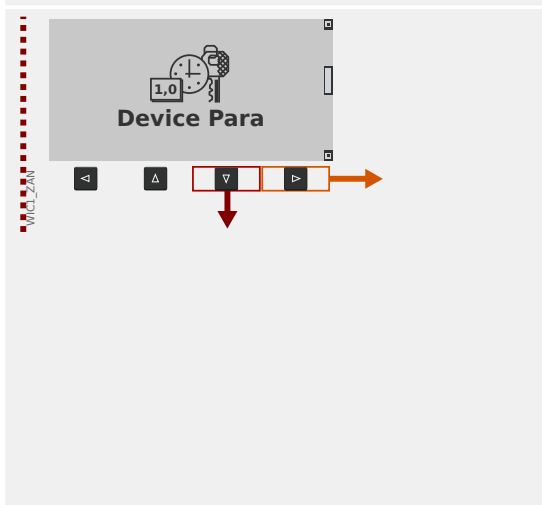
	<p><b>Operation</b></p> <p>Here you can find run-time data.</p> <ul style="list-style-type: none"><li>• Measured Values</li><li>• Status Display</li><li>• Recorders</li><li>• Self-Supervision</li><li>• reset</li></ul>
	<p><b>Device planning</b></p> <p>This will usually be your first step during commissioning:</p> <ul style="list-style-type: none"><li>• Within sub-menu WIC1 + DiggiMEC, you can specify fundamental properties of your device setup. In particular, you can define for a WIC1-2 (with DIP switches) or WIC1-3 (with HEX switches) whether the protection configuration shall be made via switches or via DiggiMEC / Smart view.</li></ul> <p>(See <a href="#">▶</a> “Validity of the DIP-/HEX-Switches” for details.)</p> <ul style="list-style-type: none"><li>• Within sub-menu Projected Elements, you can activate the elements that you need, and deactivate elements that are not needed.</li><li>• Within sub-menu Definition, you can define for each element (if it makes sense) whether it shall operate as a protection function (i. e. being able to trip the circuit breaker) or as a supervision function (i. e. issuing an alarm message instead of a trip signal).</li></ul>
	<p><b>Device Parameters</b></p> <p>This menu branch features all settings that are directly related to the device, for example:</p> <ul style="list-style-type: none"><li>• Inputs and outputs</li><li>• (DiggiMEC) LEDs</li><li>• Settings for the automatic reset and - for some WIC1 variants - for the external reset</li><li>• Password setting</li><li>• In sub-menu Version, you can check all versioning details about the running WIC1 firmware and DiggiMEC firmware.</li></ul>

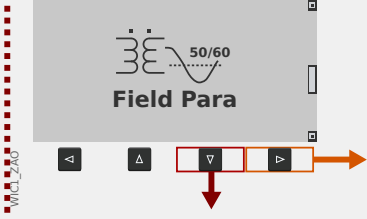
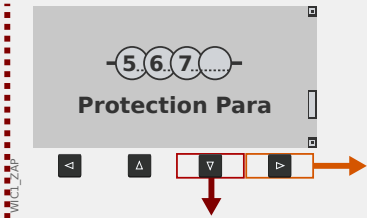
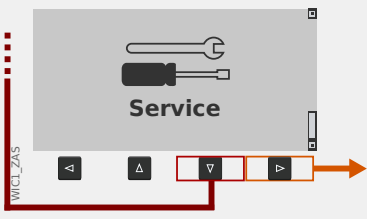
	<p><b>Field settings</b></p> <p>Usually the second commissioning step: Configure the properties of the field, for example:</p> <ul style="list-style-type: none"><li>• Nominal frequency, current</li><li>• CT ratios</li></ul>
	<p><b>Protection Parameters</b></p> <p>All protection settings, which are related to a specific protection function, can be found here in various sub-menus.</p>
	<p><b>Service</b></p> <p>This menu branch contains some special functions:</p> <ul style="list-style-type: none"><li>• Force a WIC1 restart.</li><li>• Force a trip command.</li><li>• Force a reset of all settings to their factory defaults.</li><li>• Force a temporary transition of the WIC1 into the backup protection mode (for testing purposes).</li></ul>

### 3.10.1.5 Parameter Changes - "OK" key

Whenever setting values are being modified the key »↵« is used (which is also called »OK« or »Enter« key for the sake of simplicity). This makes the device accept the new value. But note that for modifying one value, the »↵« key must be pressed a second time: When pressing »↵« for the first time, the new value is stored temporarily. Only after it has been pressed for a second time, the new value (and all other changed values) get(s) activated. This way it is possible to prepare a lot of settings changes, and only after all changes have been made consistent and as required for the (new) protection concept they can be activated all at once.

**NOTICE!**

**!** Make sure that WIC1 and DiggiMEC are sufficiently supplied, especially when both are supplied by the CTs. A sag of the supply might result in losing all parameter changes that have not been transferred to the WIC1 yet.

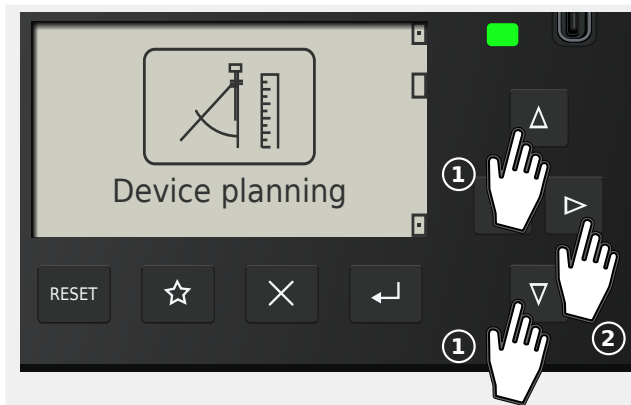

For example, let us assume we want to modify the value of »IG>> . Mode«.

This setting can be found in the [Device planning / Projected Elements] menu branch (which can be seen, for example, in the Reference Manual). The purpose of the parameter is to activate (or deactivate) the protection function »IG>>« (i. e. the 2<sup>nd</sup> stage of the Ground Overcurrent protection).

Use the arrow keys »▼«, »▲« to select Device planning menu branch, then »▶« to enter it.

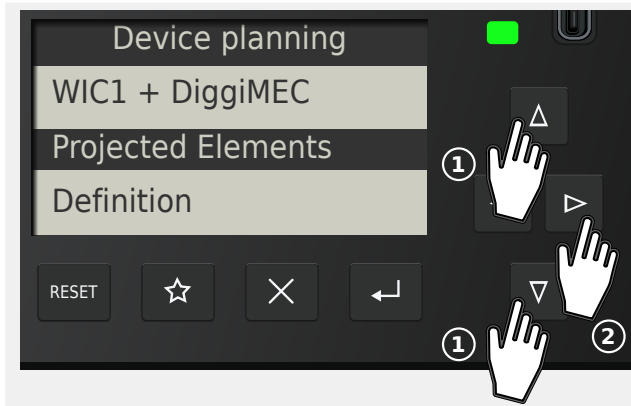

In the same way, select and enter the (sub-)menu item Projected Elements.

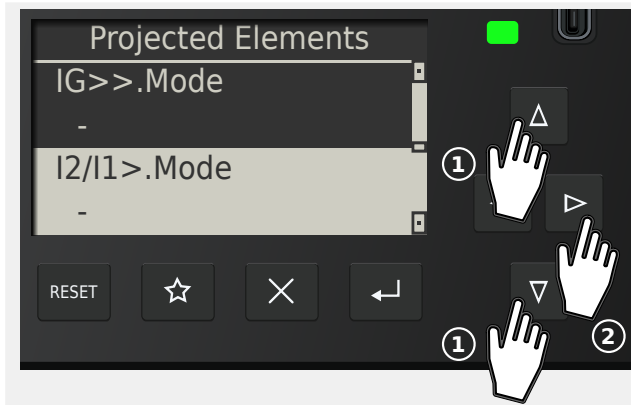

Then press »▼«, »▲« repeatedly, until the required setting appears highlighted on the display.

Press »▶« to enter the Edit Mode for this particular setting.

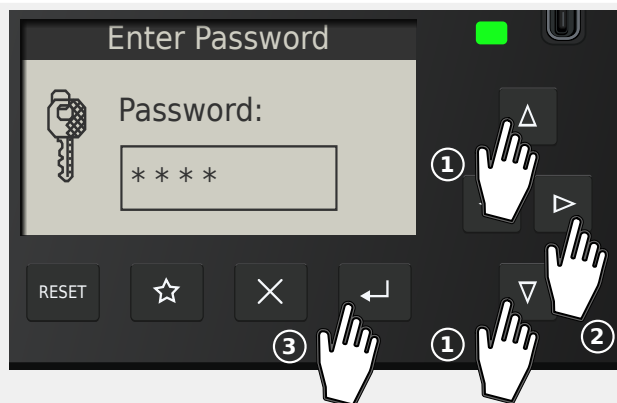

You are asked for the password.

On the DiggIMEC panel, the password is entered the same way as any numerical setting value, i. e. via navigation keys »◀«, »▶« for the position (= selection of the position/digit within the password) and »▼«, »▲« for increasing/decreasing the digit. The Enter key »↵« confirms the entered password. (A Smart view user enters the password simply via the PC keyboard.)

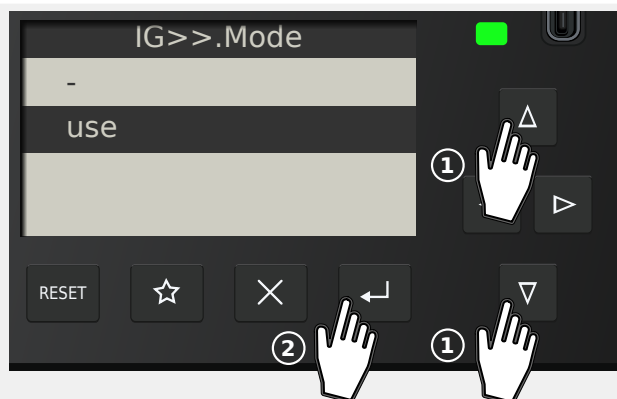

Press »▼«, »▲« repeatedly again, until the required value, for instance: “use”, is highlighted.

Then press the »↵« key, so that this new value gets stored (temporarily). (Or, alternatively, press the »✕« key to cancel the modification.)

Note that the new value is only stored internally, but not active yet, just as was already mentioned at the beginning of this chapter.

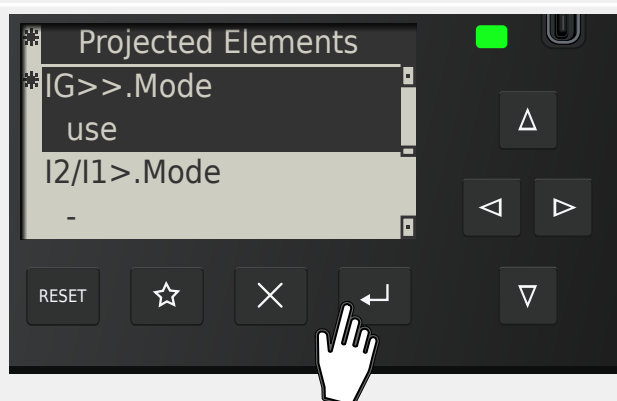

That first »↵« pressing that you have just done brings you back to the screen showing the selected parameter, »IG>> . Mode«.

However, some things have changed now:

- Now the new value “use” is shown.
- An asterisk character “\*” next to the parameter indicates that there are temporary changes for it. In addition, another asterisk next to the heading line indicates that parameter changes exist that have not yet been accepted and activated by the device. (The “\*” remains there, even if one navigates to some other menu branch.

Remark: If there is no more input made at the panel for 10 minutes the changes are automatically cancelled.

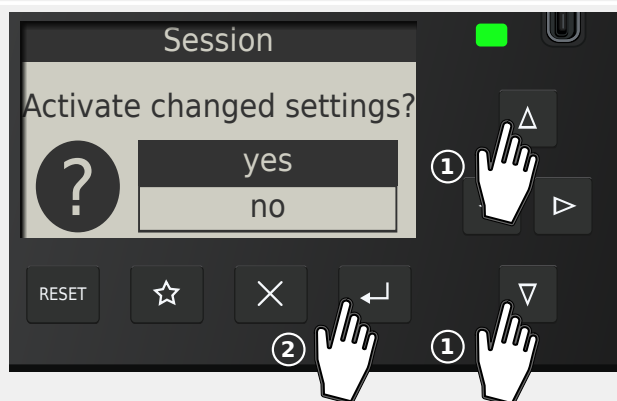

Press »↵« again. (In principle, this can also be done later, i. e. after some more parameter changes and when being in another menu branch.)

A confirmation dialog asks you to explicitly accept your changes. Make your choice in the usual manner with the keys »▼«, »▲«, »↵«.

### 3 Hardware

#### 3.10.1.5 Parameter Changes - "OK" key

The protection device performs a validity check, and after this, it uses the new setting (unless it detects a validity problem).



If the validity check should fail, i. e. the protection device detects some validity problem or inconsistency with respect to the new value(s) then this is indicated by a big "?" character that appears instead of the "\*" in the heading line. In this case the protection device refuses to activate the new value(s), and you are expected to re-edit the values that are marked by the "?".



### 3.10.1.6 Operation via Smart view

Although it is easy and convenient to operate a WIC1 using the panel of a connected DiggiMEC, a full configuration session with many settings to be made would be a quite cumbersome activity. For numerous operations, the preferred way is to connect a PC with an operating software to the protection device, so that everything can be done using computer mouse and keyboard and the large computer monitor gives a far better overview about the available menu branches, than is possible with the device's built-in display. Moreover, the PC allows for saving all settings as a file, that can be archived and be loaded into a WIC1 at any later time.

SEG offers an operating software named *Smart view*. It offers convenient ways to do all configuration work, reading and evaluating measuring values, fault analysis via fault recorder, and much more. A detailed *Smart view* Manual is available as a separate document.

#### Setting up the Connection PC - Device

A PC connection can be established only via a connected DiggiMEC.

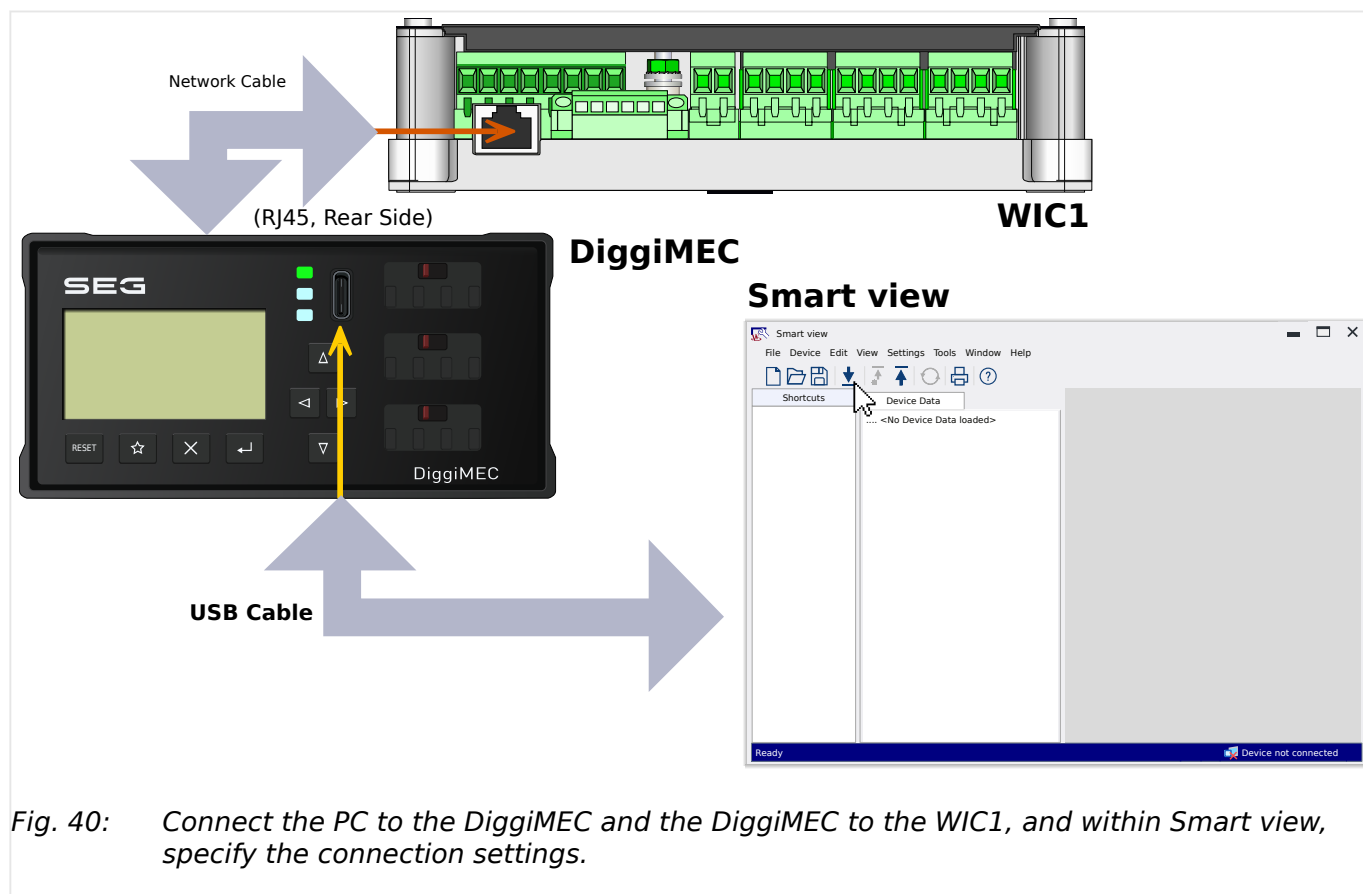

Fig. 40: Connect the PC to the DiggiMEC and the DiggiMEC to the WIC1, and within Smart view, specify the connection settings.

Apart from plugging in the required cables, there are essentially two steps to be done for establishing a connection:

- In *Smart view*, click on [*Settings* → *Device Connection*], then select the type of connection to be used for the device, here: »WI Line (V2) DiggiMEC USB«.

After this, the connection has not been established yet, therefore you should not be confused if the status line still shows "Not connected".

- Click on [*Device* → *Receive Data from Device*] (or, alternatively, press »F2« on your keyboard, or click on the small icon with the blue arrow pointing down).

*Smart view* should now retrieve the complete menu tree, including all setting values and run-time data. After that, you should see a menu tree with the same top-level categories as on the DiggIMEC panel.

**NOTICE!**



If *Smart view* complains about a missing “device model” then your *Smart view* installation is probably older than the WIC1 firmware.

The “device model” is a file that defines the menu tree and all parameters, including factory defaults and setting ranges. It is needed by *Smart view* for showing the menu tree correctly and for making offline settings possible.

For the recent and all previous Releases of the WIC1 firmware, the “device model” is part of the *Smart view* installation. So, if a WIC1-“device model” is missing, please install the latest *Smart view* version.

After the menu tree has been made available within *Smart view*, all further activities, such as changing a setting value, are straight-forward (and do probably not need a lot of detailed explanations): You can expand the (sub-)menu branches of any menu branch (click on the small angle next to the menu item, or a double-click on the item name), until you reach the required bottom-level item.

### 3.10.2 DiggiMEC Connectors

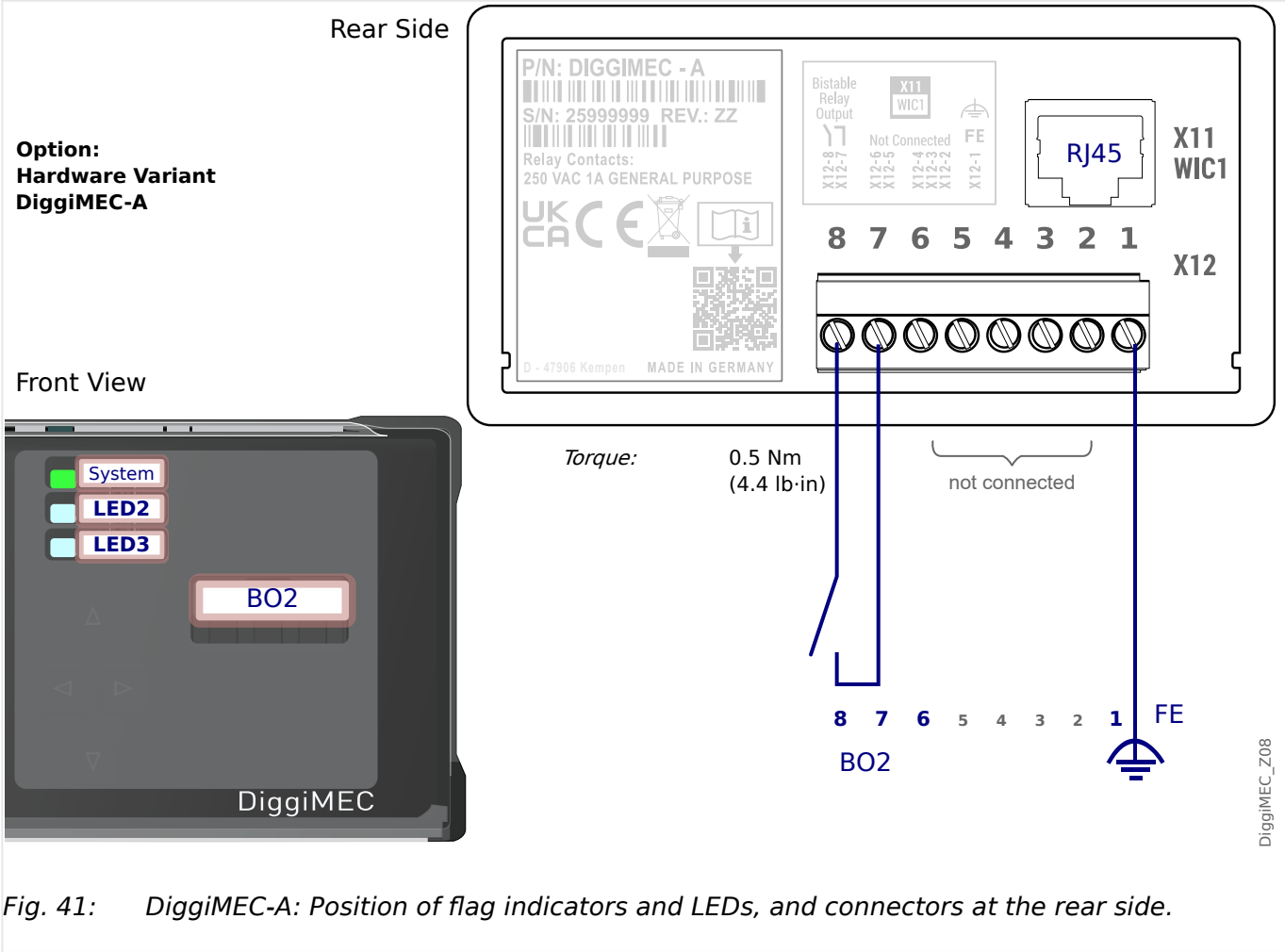
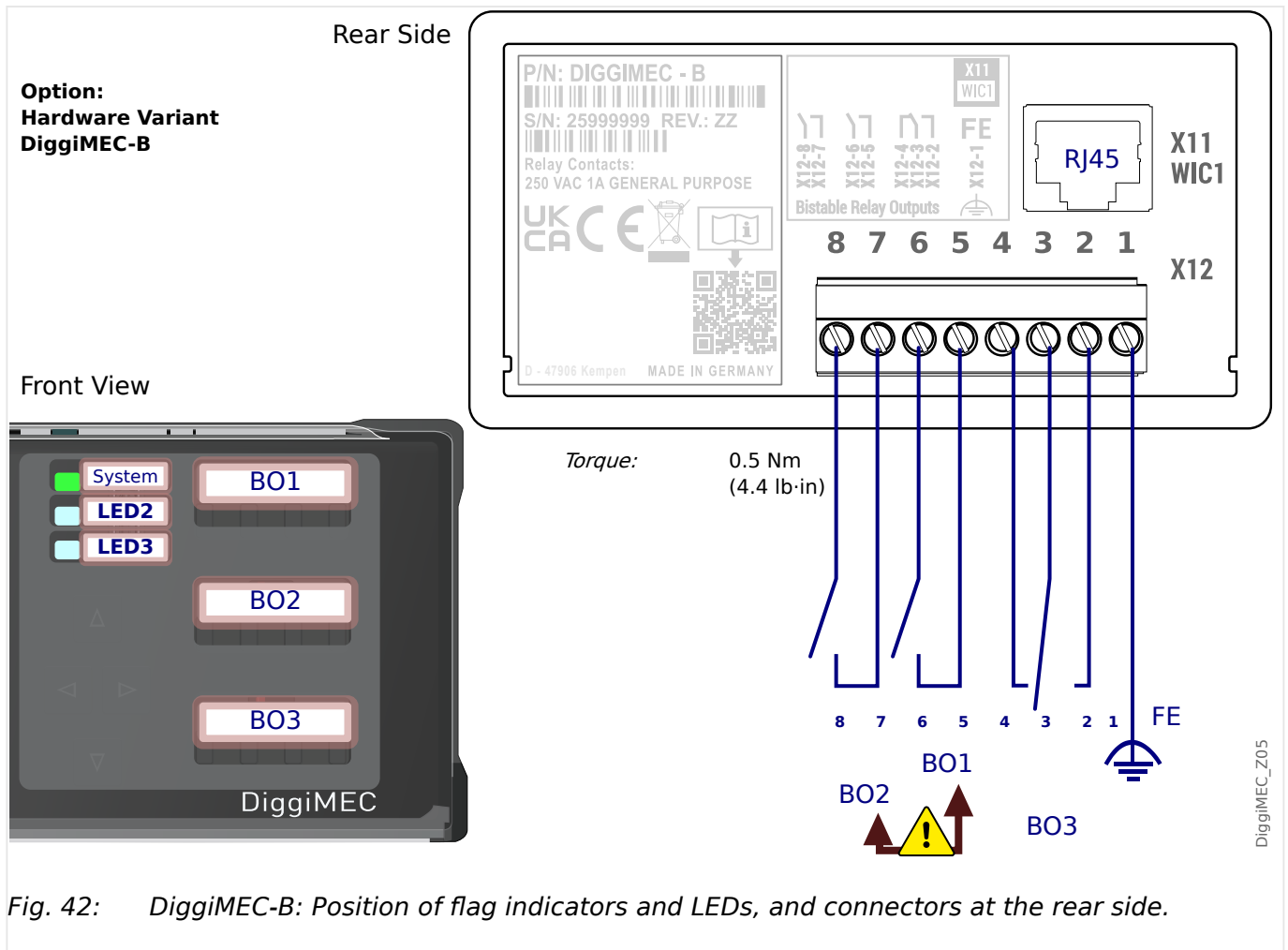

Fig. 41: DiggiMEC-A: Position of flag indicators and LEDs, and connectors at the rear side.



Slot	Max. Torques of the Screws	Screw type	Description
X12	0.5 Nm (4.4 lb·in)	M3 slotted	Connections for functional earth and relay outputs
X11	—	—	RJ45 connection to the WIC1. Ethernet CAT3 cable or better, but beware, this is not an Ethernet connection! <b>Crossover cables must not be used!</b>

**Functional Earth (“FE”)**

The DiggiMEC must be grounded:

**WARNING!**



A ground connection (functional earth, min. 2.5 mm<sup>2</sup> [≲ AWG 13], tightening torque 0.5 Nm [4.4 lb·in]) must be connected at the “FE” terminal, see diagram [↪ Fig. 42](#)).

In general, all grounding connections must be low-inductance, i. e. as short as possible, and national standards – if applicable – must be followed.

## RJ45

The DiggiMEC features an RJ45 connector on the rear side. Use a standard network cable (CAT 3 or better) to connect the DiggiMEC to the DiggiMEC-RJ45-connector of a WIC1.

### NOTICE!



Although the communication between DiggiMEC and WIC1 is transferred over a network cable, note that this is not an Ethernet communication. In fact, a proprietary protocol is used.

Some WIC1 variants feature another RJ45 connector, that can be used for Ethernet-based communication, in particular TCP/IP-based SCADA protocols. This Ethernet-RJ45 connector must **not** be used for a direct connection with a DiggiMEC.

## Relay Outputs

The “Outputs” terminals feature:

- For device variants DiggiMEC-**A**, one normally-open (Form A) relay contact, that is mechanically connected with a flag indicator.  
  
(Note that this contact is labeled as BO2 within the WIC1 configuration.)
- For device variants DiggiMEC-**B**, one changeover (Form C) and two normally-open (Form A) relay contacts. Each of these three relay outputs is mechanically connected with one of the three flag indicators.

All relay contacts are bistable and potential-free. They can be triggered by a digital signal from the WIC1. Since each relay is mechanically connected to a flag indicator, switching a relay means that the corresponding flag indicator starts to show its signal, and vice versa.

Further details, in particular about the settings at the WIC1, are here: [↪ “3.10.3 Flag Indicator / Output Relays Settings \(DiggiMEC\)”](#)

### WARNING!



The bistable output relays of a DiggiMEC, that is connected to the WIC1, may be used only for visualization purposes. It is not permitted to use these relay contacts for any protection-related and/or switching purposes!

If the DiggiMEC relays are used for switching purposes there is the risk of an unreliable protection of your application!

Only the trip-coil output “TC+/-” of the WIC1 may be used for tripping a breaker.

Remarks with respect to this warning:

- The switching time of the “TC+/-” output is faster than that of a DiggiMEC output relay. Therefore it is strongly discouraged to use a DiggiMEC output relay for any protection-related switching purposes.
- It is possible to assign the WIC1 signal »Prot . TripCmd« to a DiggiMEC output relay. This is absolutely o.k. for visualization purposes. But there is no signaling back of a DiggiMEC relay status to the WIC1. This has the consequence that the WIC1 cannot realize any signaling/switching problem if – for instance – there is no DiggiMEC connected to the WIC1, or if there should be any technical problem with the DiggiMEC. In such a case the whole protection concept can be void.

- It is technically possible and permitted to switch the relay contact manually. But if a breaker should be connected directly to a DiggiMEC output relay, it would be opened by such a manual switching, and the WIC1 would not be able to detect this. This makes the whole protection concept unsafe and not permissible.
- The WIC1 Backup Protection cannot switch a DiggiMEC output relay. It only uses the "TC+/-" output.

### 3.10.3 Flag Indicator / Output Relays Settings (DiggiMEC)

Depending on the [ordered type](#), the DiggiMEC features either one flag indicator FI2, or three flag indicators FI1, FI2, FI3.

See also [↩️ “3.10.2 DiggiMEC Connectors”](#).

Each of these flag indicators is mechanically coupled with a bistable output relay.

#### WARNING!



The bistable output relays of a DiggiMEC, that is connected to the WIC1, may be used only for visualization purposes. It is not permitted to use these relay contacts for any protection-related and/or switching purposes!

If the DiggiMEC relays are used for switching purposes there is the risk of an unreliable protection of your application!

Only the trip-coil output “TC+/-” of the WIC1 may be used for tripping a breaker.

At any time, the WIC1 can toggle the state of an Flx. Note that each Flx is always only set with the rising edge of the assigned signal.

With respect to the DiggiMEC flag indicators, there is the following convention: In the state appearing as a red-colored mark at the DiggiMEC front the flag indicator / output relay has been “set”, and the other state means that the Flx has been “reset”.

#### WARNING!



A CT-powered WIC1 is able to reliably set and reset the flag indicators only under the condition that it is supplied with sufficient electrical energy via the CTs. (Unfortunately the required electrical energy depends on various aspects, e. g. how many flag indicators shall be switched at the same time, or whether the impulse outputs shall be triggered, too. Therefore it is impossible to explicitly specify any limit value.)

#### CAUTION!



It is not possible for the WIC1 to check the current state of any Flx. So, if the user mechanically changes the state of an Flx the new state is not signaled to the WIC1.

In other words: Although it is possible at any time to change the state of an Flx by hand, this should only be done with great care, being aware of potential consequences, because this also switches the state of the output relay contacts.

After a reset (via HMI or Digital Input), however, all Flx - regardless whether with or without latching - (re-)assume their correct states according to the current state of the assigned signals. (Important: The reset is functional only if the WIC1 settings have specified which DiggiMEC variant is connected; the related parameter is [Device planning / WIC1 + DiggiMEC] »DiggiMEC . Mode«.)

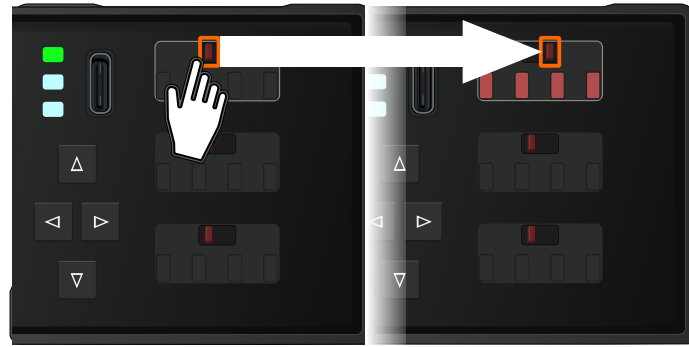

DiggiMEC\_Z07

Fig. 43: Important: Manually toggling the state of a flag indicator also switches the contacts of the respective output relay.

The conditions of a module output or signal of a protective function can be assigned to an Flx, so that it is both electrically available (via the relay contacts) and visualized (via the flag indicator). Since the Flx are bistable the last state remains available even after the WIC1 and DiggiMEC are no longer supplied (i. e. have been switched off).

All output relay contacts are potential-free. Each relay can be assigned a signal out of the »assignment list«.

#### NOTICE!



Whenever the DiggiMEC is not actively used by a human operator we recommend to keep the lid closed. (Depending on the local security directives you might also want to use the sealing option.)

This prevents an unintended re-positioning of the flag indicators / output relays. Furthermore, it reduces the risk of dust or dirt intruding into the mechanics of the flag indicators.

Within menu branch [Device Para / DiggiMEC / FI / BO], set the following parameters for each Flx:

- »Assigned signal«: The parameter »Flx assign.« assigns a trigger signal to Flx.
- With the setting »Flx latching« = “No latching”, the Flx continuously adopts the state of the assigned signal.
- If »Flx latching« is set to “With latching” or to “Latch. w. Auto-Reset”, the state that is set by the trigger signal is permanently stored. (For details see [↪ “3.10.3.1 Latching”](#).)

Each Flx can only be reset - “acknowledged” - after the signal that had initiated its setting has dropped out.

### 3.10.3.1 Latching

After the assigned signal has become active a latched Flx keeps its state until it is acknowledged, or some automatic reset occurs.

A latched Flx gets reset only in any of the following cases and only after the assigned trigger signal has dropped out.



The following latching modes are settable via [Device Para / DiggiMEC / FI / BO] »Flx latching«:

- “No latching” – The status of the flag indicator immediately follows the status of the assigned signal.
- “With latching” – When the assigned signal gets active it sets the flag indicator, which stays set. After the assigned signal has dropped off the flag indicator can be electrically reset by the device.
- “Latch. w. Auto-Reset” – latching with automatic reset, see also [↳ “2.12.1 Automatic Reset”](#).

### 3.10.3.2 Testing the Flag Indicators / Output Relays

The correct functioning of the flag indicators can be verified by the steps following below.

Please consider that the test requires switching the flag indicators, which also changes the electrical state of the relay contacts. Therefore you should only carry out the test if this is acceptable.

After the test has been carried out successfully each flag indicator / output relay is reset to the state of the assigned signal.

#### **Verify that the Flx Show the Correct State:**

- |      |   |
|------|---|
| ⚙    |   |
| 1. ▷ | Execute a reset command, [Operation / Reset] »Rst. LEDs, Fls«.  |
| 2. ▷ | <ul style="list-style-type: none"> <li>• The assignments are shown at [Device Para / DiggiMEC / FI / BO].</li> <li>• The states are shown at [Operation / Status Display].</li> </ul> |
| ▶    | The assigned states and the flag indicators must be matching each other.  |

#### **Verify that the Flx Can Change Their State:**

- |      |   |
|------|---|
| ⚙    |   |
| 1. ▷ | Verify that the current Flx states are correct, as described above.                         |
| 2. ▷ | Then toggle the Flx to the opposite state manually, as shown in <a href="#">↳ Fig. 43</a> . |
| 3. ▷ | Finally execute a reset command (again), [Operation / Reset] »Rst. LEDs, Fls«.              |
| ▶    | The Flx must return back to their correct / verified state.                                 |

## 4 Communication Protocols (WIC1-4 only)

### 4.1 Modbus® (WIC1-4 only)

#### **Modbus® Protocol Configuration**

The Modbus® communication protocol is available with WIC1-4 devices that are equipped with a serial interface (“Modbus RTU”), see [“3.7 Serial Interface RS485 \(WIC1-4... only\)”](#).

The standard protocol definition (mapping of data-points) that comes with the WIC1 is sufficient for most applications, so that only a few settings have to be made (see below).

The time-controlled Modbus® protocol is based on the Master-Slave working principle. This means that the substation control and protection system sends an enquiry or instruction to a certain device (slave address) which will then be answered or carried out accordingly. If the enquiry/instruction cannot be answered/carried out (e. g. because of an invalid slave address), a failure message is returned to the master.

#### **NOTICE!**



Some signals (that are for a short time active only) have to be acknowledged separately (e.g. Trip signals) by the Communication System.

The Master (substation control and protection system) can query information from the WIC1-4 and give commands. For detailed information on data point lists and error handling, please refer to the Modbus® documentation. Moreover, there is a WIC1 Modbus Specification document, and the datapoints are listed in Microsoft Excel® format.

#### **Setup**

At first the type of Modbus protocol has to be selected:

Set [[Device planning / Projected Elements]] »*Modbus . Mode*«

- = “RTU” — use the Modbus® protocol over a serial connection

Then continue with the settings described below for Modbus RTU.

#### **Modbus RTU**

##### *Part 1: Configuration of the Devices*

Enter the menu [Device Para / Modbus / Communication / RTU] and set the communication parameters there. (See see Reference Manual.)

Also, select some RS485 interface-related parameters from there, see Reference Manual.

##### *Part 2: Hardware Connection*

- For hardware connection to the control system, see [“3.7 Serial Interface RS485 \(WIC1-4... only\)”](#).
- Connect bus and device (wiring).

Information on physical communication data and errors are available from dedicated diagnosis counters, see Reference Manual.

## 5 Protective Elements

### 5.1 »Prot« - General Protection Module

The module “General Protection” (»Prot«) serves as outer frame for all other protection modules, i. e. a master module that is connected to all protection stages.

#### **Definition (“Alarm ↔ Trip”) of a Protection Function**

It is possible for every protection stage to define during the commissioning setup whether this stage shall issue a trip signal in case of a fault, so that the circuit breaker gets opened, or whether the stage shall simply issue an alarm signal, without tripping. This setting can be done within the menu [Device planning]. This menu branch features a setting parameter »Definition« for each protection stage.

- In general, a fault leads to a pickup of the respective protection stage. If the stage is not blocked the signal »Pickup« is issued, and this is also (internally) reported to the master module »Prot«.

The further operation depends on the category of the protection stage:

- »Definition« = “Alarm” — **The protection stage operates as a pure supervision function**, this means:

- A protection pickup does not issue a General Pickup »Prot . Pickup«. Instead, if the fault persists after a settable timer has elapsed (see [Fig. 44](#)), an alarm signal »Alarm« is issued, which is also (internally) reported to the master module »Prot«.
- The master module »Prot« then issues a General Alarm, this is the signal »Prot . Alarm«.

If the protection stage is phase-selective then also the respective signals »Alarm IL1«, »Alarm IL2«, »Alarm IL3« are issued. (These signals, however, are **not** reported to the »Prot« module. But just like every signal, these can be directly viewed within the respective menu branch.)

- »Definition« = “Trip” — **The protection stage operates as a “full” protection stage and is able to trip the circuit breaker:**

- The master module »Prot« then issues a General Pickup. The respective signal is labeled »Prot . Pickup«.

If the pickup comes from a phase current protection stage the additional signal »Prot . Pickup I Ph« is issued.

If the pickup comes from a ground (earth) current protection stage the additional signal »Prot . Pickup IG« is issued.

If the pickup comes from a phase-selective protection stage then the faulty phase(s) can be seen from the additional respective signal(s) »Prot . Pickup IL1«, »Prot . Pickup IL2«, and/or »Prot . Pickup IL3«.

- If the fault persists after a settable timer has elapsed – see also [Fig. 44](#):

A trip signal »Trip« is issued, which is also (internally) reported to the master module »Prot«.

- The master module »Prot« then issues a General Trip, this is the signal »Prot . Trip«.

If the protection stage is phase-selective then also the respective signals »Trip IL1«, »Trip IL2«, »Trip IL3« are issued and (internally) reported to the master module »Prot«.

- In this case the master module »Prot« also issues the respective phase-selective »Prot . Trip IL1«, »Prot . Trip IL2«, »Prot . Trip IL3«.
- Finally the master module »Prot« generates a trip command, the signal is »Prot . TripCmd«.

Along with a trip command, a sequence of trip impulses is generated, that are output as voltage pulses at the trip terminal of the WIC1. With correct wiring, these pulses trigger the circuit breaker to be opened.

If a DiggIMEC is connected, a pop-up window is sent onto the display in order to draw the user's attention to the fault. (See [↪ “6.1 Fault Display screen \(Overlay / Pop-up\) on the DiggIMEC”](#).) This might be helpful for fast fault analysis.

#### NOTICE!



After the circuit breaker has tripped, a CT-powered WIC1 variant is switched off, because it is obviously no longer supplied via any CT current. The fault event, however, is recorded in a non-volatile memory and can be read (after the next WIC1 startup). See also [↪ “6 Fault Recorder”](#).

### 5.1.1 General Pickup, General Alarm, General Trip

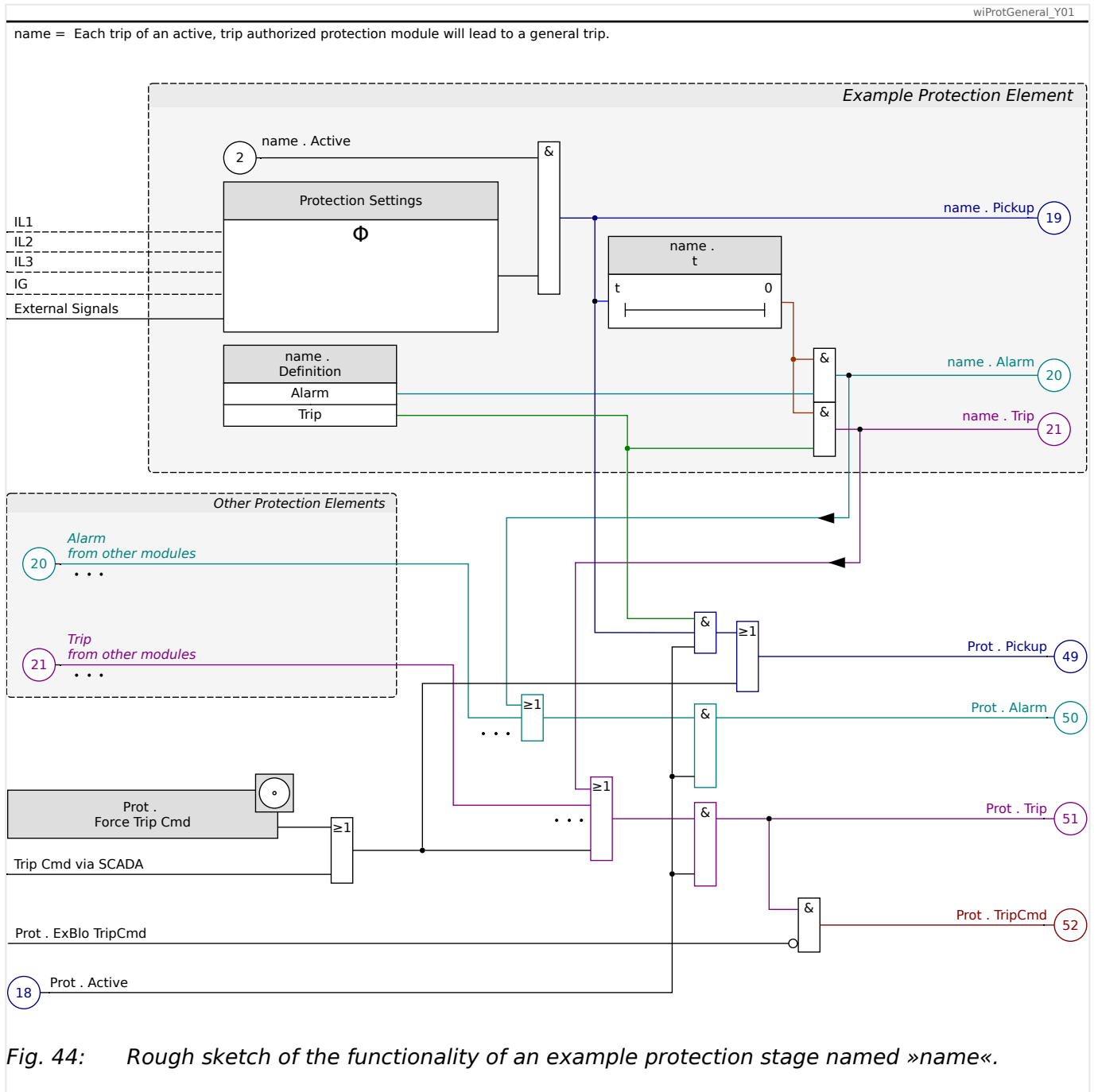

The diagram visualizes the protection signals of any WIC1 protection stage, »name«, and how these are reported to the »Prot« master module. However, the phase-specific signals and the collective signals »Prot . Pickup I Ph« and »Prot . Pickup IG« have been omitted to make the concept better understandable.

### 5.1.1.1 Trip Pulse and WIC1 LEDs

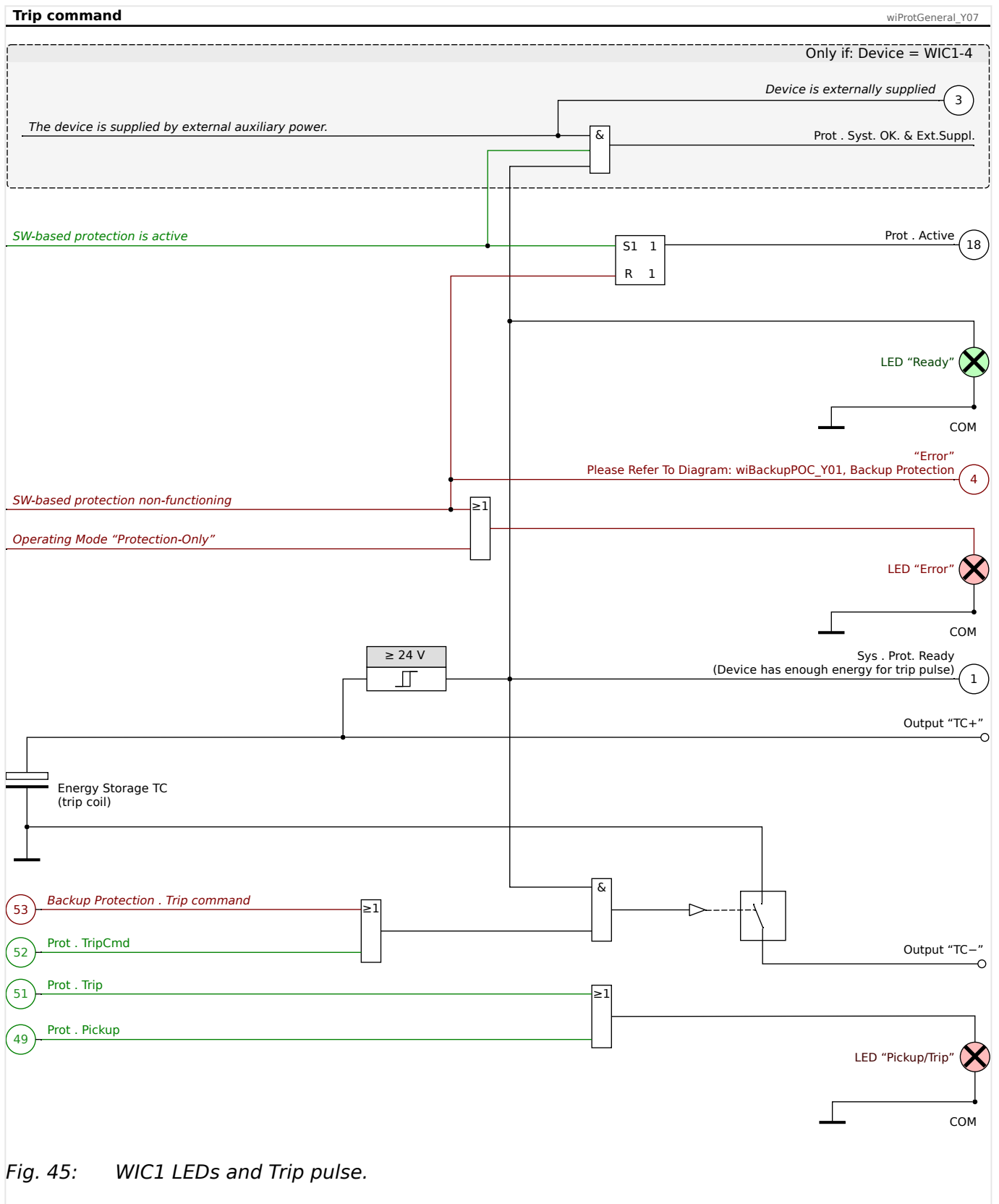

Fig. 45: WIC1 LEDs and Trip pulse.

Note that the trip pulse is output like shown in the diagram, by connecting the "TC-" contact internally with COM. A detailed description of the WIC1 LEDs can be found in ["3.9.1 LEDs"](#).

The signals and line connections in dark red color can be active only if the Self-Supervision of the WIC1 has determined an internal problem. The signals and line connections in green color can be active only if the software-based protection functions are all healthy.

The signal »Prot . Active« - labeled as number ( 18 ) in the diagram - gets active as soon as the WIC1 has started and activated the (software-based) protection modules. This is also true of the “Protection-Only” operating mode. But if the Self-Supervision has determined the software-based protection as non-functioning only the Backup Protection is running and **all** signals are inactive. (The latter fact is indicated in the diagram by inactivating ( 18 ) »Prot . Active« via the “R” Reset input of the S&H block. Of course, this is merely a makeshift: If the WIC1 software is not functioning there can be no correct visualization of the internal functionality.)

**NOTICE!**



A General Pickup signal makes the “Pickup/Trip” LED flashing red, and a General Trip signal makes the “Pickup/Trip” LED shine constantly red (as long as the WIC1 is still being supplied with power and the signal is active).

There is no latching of this LED. (See also [↩➡](#) “3.9.1 LEDs”.)



### 5.1.1.2 Phase-Selective Signals, Collective Signals

In addition to the signals shown in the diagram [Fig. 44](#), the »Prot« module also features collective signals and phase-selective signals. The phase-selective signals can be issued by protection modules that are able to detect 1p faults.

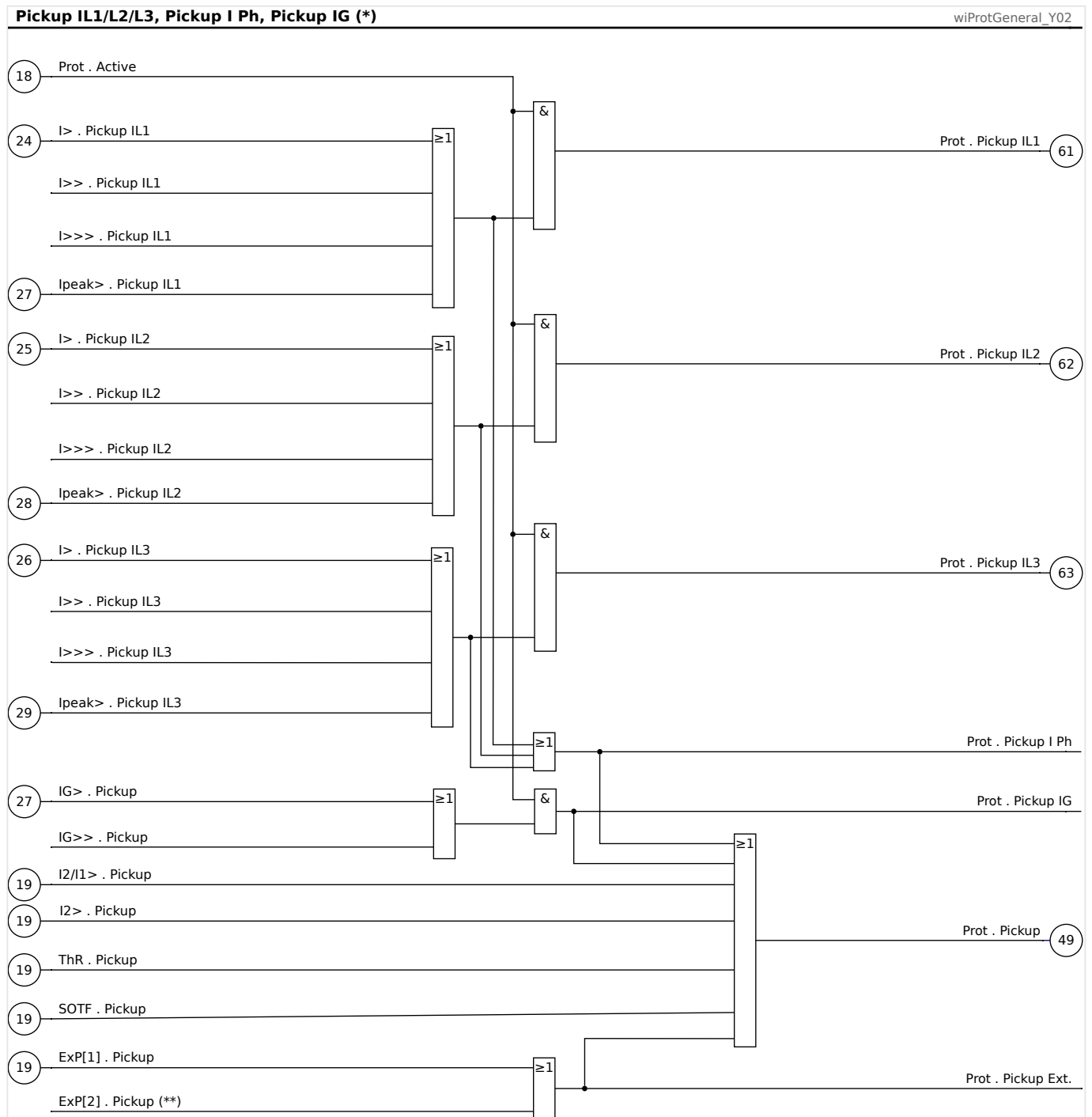

**Fig. 46:** Phase-selective General Pickup signals and the respective collective signals.

(\*) All General Pickup signals, including the phase-selective ones, are issued only by protection functions that are set as »Definition« = "Trip". (See also ["Definition \("Alarm ↔ Trip"\) of a Protection Function"](#).) This is not shown explicitly in the diagram.

(\*\*) A second »ExP« instance is available only on WIC1 variants with two Digital Inputs. (See [order options](#).)

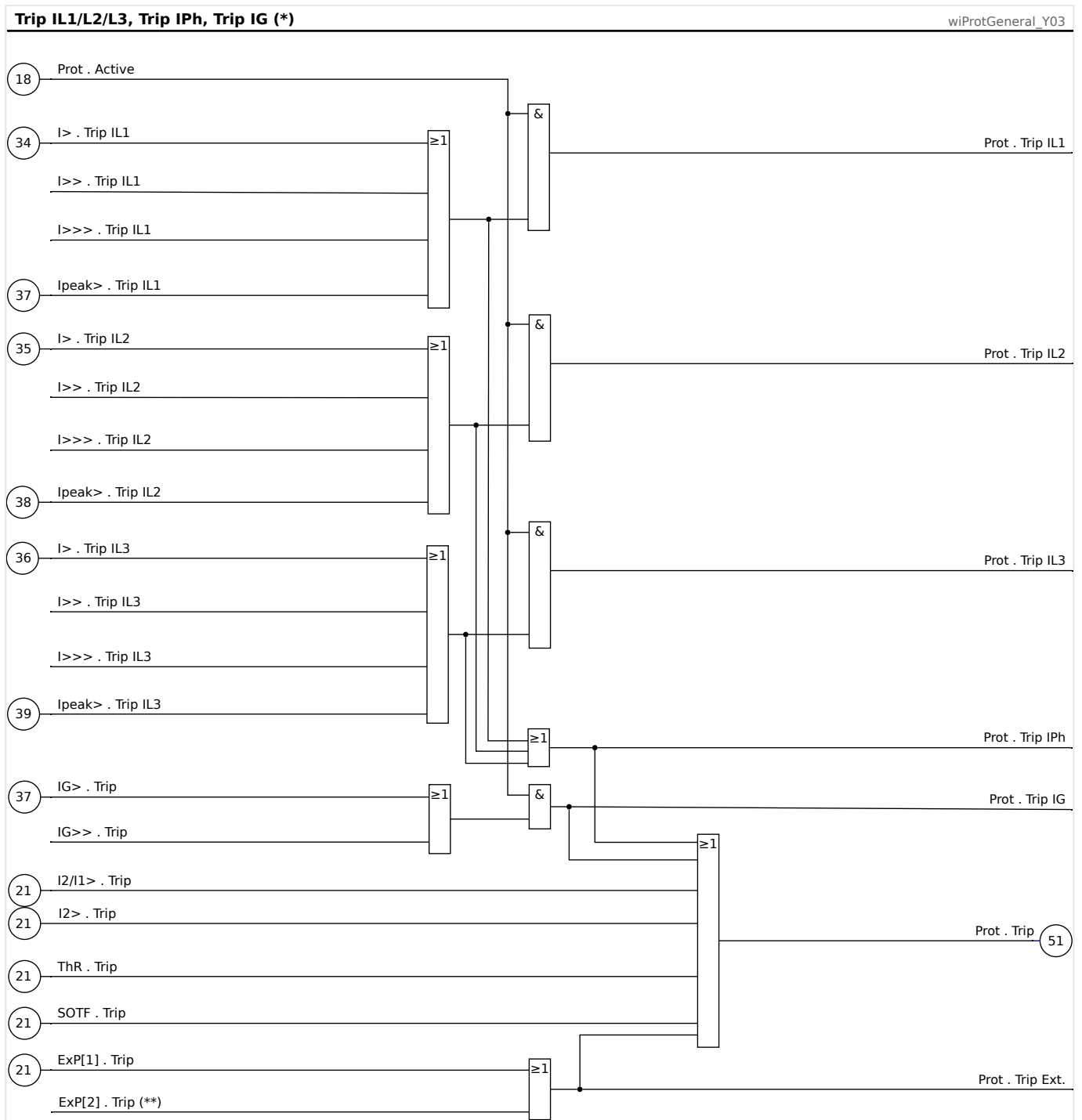



Fig. 47: Phase-selective General Trip signals and the respective collective signals.

(\*) All trip signals, including the phase-selective ones, are issued only by protection functions that are set as »Definition« = "Trip". (See also [Definition \("Alarm ↔ Trip"\) of a Protection Function](#).) This is not shown explicitly in the diagram.

(\*\*) A second »Exp« instance is available only on WIC1 variants with two Digital Inputs. (See [order options](#).)

## 5.1.2 Force Trip Command

For commissioning or testing purposes, the user can initiate a trip command manually via [Service / Prot] »Prot . Force Trip Cmd«.

See also the function diagram,  Fig. 44.

But note that if the WIC1 is supplied only via USB then the voltage of the trip pulse might be too low to actually trigger the breaker. See also  “2.3 Supply of a WIC1” and “Troubleshooting: System-LED is Off”.

### 5.1.3 Blockings

The device provides a function for blocking of the trip command. In addition, most of the protection stages can be blocked individually.

#### WARNING!



Make absolutely sure that no illogical or even life-threatening blockings are allocated.

Make sure that you do not carelessly deactivate protection functions which have to be available according to the protection concept.

#### 5.1.3.1 Switching Protection Functions On or Off

Each of the modules can be switched on or off (permanently). This is achieved when the parameter »*Function*« is set to "Active" or "Inactive" in the respective module.

- First, in the menu [Device planning] there is for each protection stage a parameter »*Mode*«. It takes the protection stage completely out of operation (or sets it into operation).

Every protection stage that it not required by the protection concept should indeed be deactivated this way, because it then no longer uses any device-internal resources (CPU time, memory).

Furthermore, activating and deactivating of protection stages automatically takes into account all dependencies that might exist between different protection stages. And a deactivated protection stage disappears completely from all menu branches (with the sole exception of the setting »*Mode*«, that allows for (re-)activating the protection stage.

- In addition to this kind of de-/activation, there is for each protection stage a setting »*Function*«, that can be "Active" or "Inactive". The protection stage is kept operating also for »*Function*« = "Inactive", but it is not protecting, i. e. it is "switched off".

### 5.1.3.2 Temporary Blocking

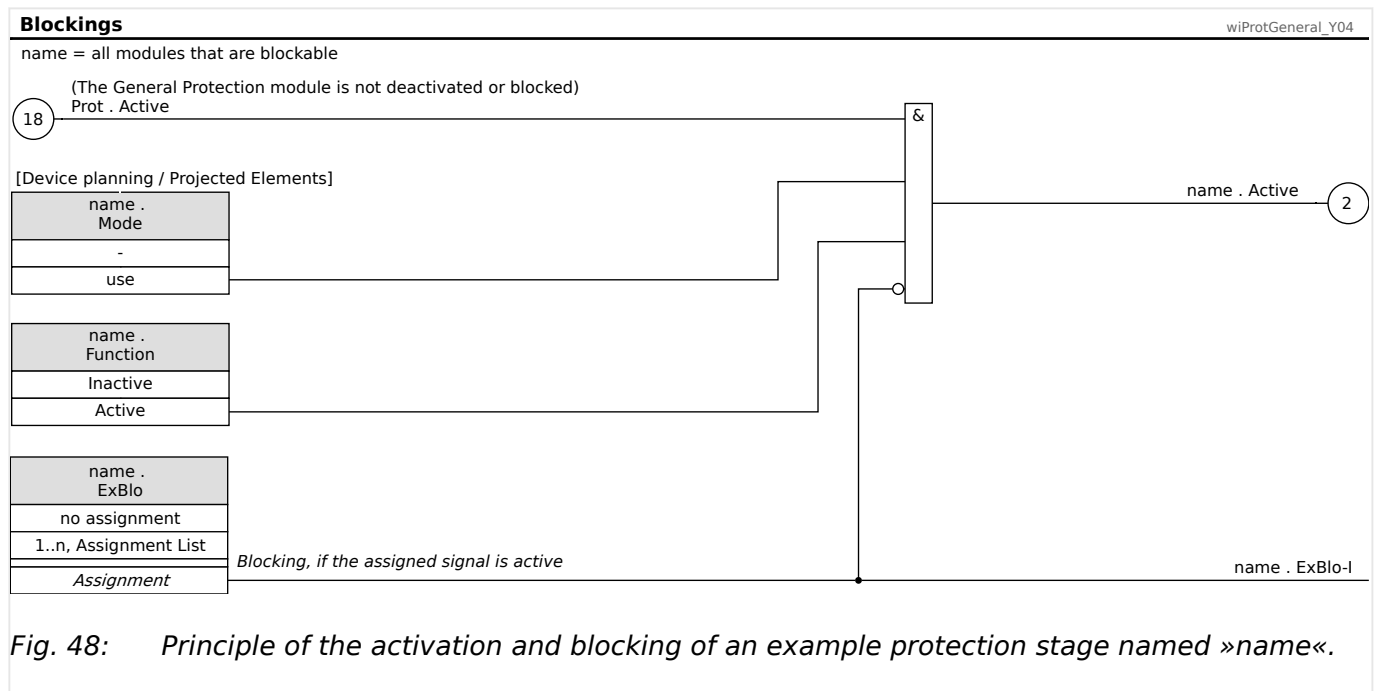

Fig. 48: Principle of the activation and blocking of an example protection stage named »name«.

To block a particular protection stage temporarily by an active signal:

- There is for each protection stage a setting »ExBlo«, to which a signal can be assigned. This signal can be selected from a list of device-internal and external signals. (“External signals” are those received from a Digital Input.) The blocking becomes active when the assigned signal is active.

## 5.1.4 Control of a Switchgear

The trip impulse output of the WIC1 (see [↳ “3.8 Outputs \(Trip Coil, Flag Indicator, Relay Output\)”](#)) needs to be connected to a switchgear that is responsible for clearing a fault that is detected by the WIC1. This is usually a circuit breaker, but depending on the particular application, other types of switchgear are in common.

### DANGER!



Misconfiguration of switchgear could result in death or serious injury. This e. g. is the case when opening a disconnecter under load or when switching a ground connector to live parts of a system.

The commissioning engineer is responsible for the correct configuration and wiring of the switchgear, including documentation of all these aspects.

A correct configuration of all switchgear is an indispensable precondition for the proper functioning of the protective device.

### 5.1.4.1 Switchgear Configuration

#### **Criteria for Determining the Switchgear Position**

The position indication is needed by the WIC1 to get (evaluate) the information about the current status /position of the breaker. This information is essential for the modules »Switch Onto Fault« ([↳ “5.10 SOTF - Switch Onto Fault”](#)) or the »Circuit Breaker Monitoring« ([↳ “5.13 CBF - Circuit Breaker Failure \[50BF, 62BF\]”](#)).

It is possible to select for the switchgear states CLOSE (“ON”) and OPEN (“OFF”), independent of each other, whether these states shall be detected based on phase currents or based on positioning indicator signals (or both). For WIC1 variants without configurable Digital Inputs, of course, only the current-based detection is applicable.

- Setting of the detection criterion for the CLOSE (“ON”) and OPEN (“OFF”) states:

[Protection Para / Breaker & Trip] »Meth.Detect.Bkr.Pos.« =

Options:

- “Aux-Based” — Signal-based detection.

(This option is available only with a WIC1-4 featuring configurable Digital Inputs.)

- “Current-Based” — Current-based detection.
- “Current and Aux” — Both criteria are used.

(Of course, this option, too, is available only with a WIC1-4 featuring configurable Digital Inputs.)

#### **Wiring (only WIC1-4 with configurable Digital Inputs)**

In case the position indication is based on signal inputs ([↳ “Wiring \(only WIC1-4 with configurable Digital Inputs\)”](#)), the particular signals have to be assigned:

- The signal for the switchgear state CLOSE (“ON”) – if wired/required – can be assigned to:

[Protection Para / Breaker & Trip] »Aux ON«

You typically assign one of the two Digital Inputs here.

- For the signal for the switchgear state OPEN (“OFF”) – if wired/required – the same assignments are available:

[Protection Para / Breaker & Trip] »Aux OFF«

You can connect one of the position indicators' contacts (either the »Aux ON« or the »Aux OFF«), so that you still have the other Digital Input available. However, for some applications it can also be recommended to connect both position indicators.

Thereafter the trip coil output has to be connected with the switchgear.

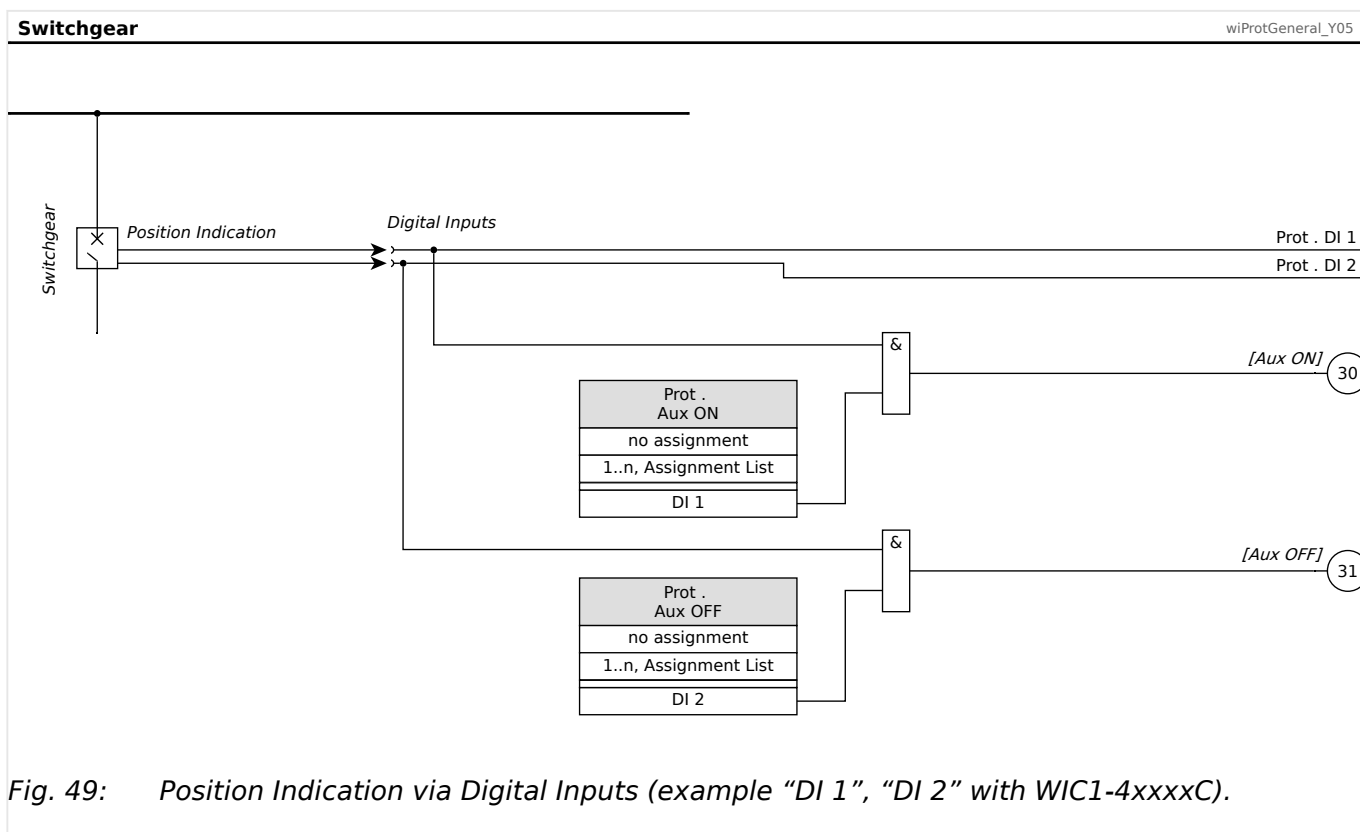
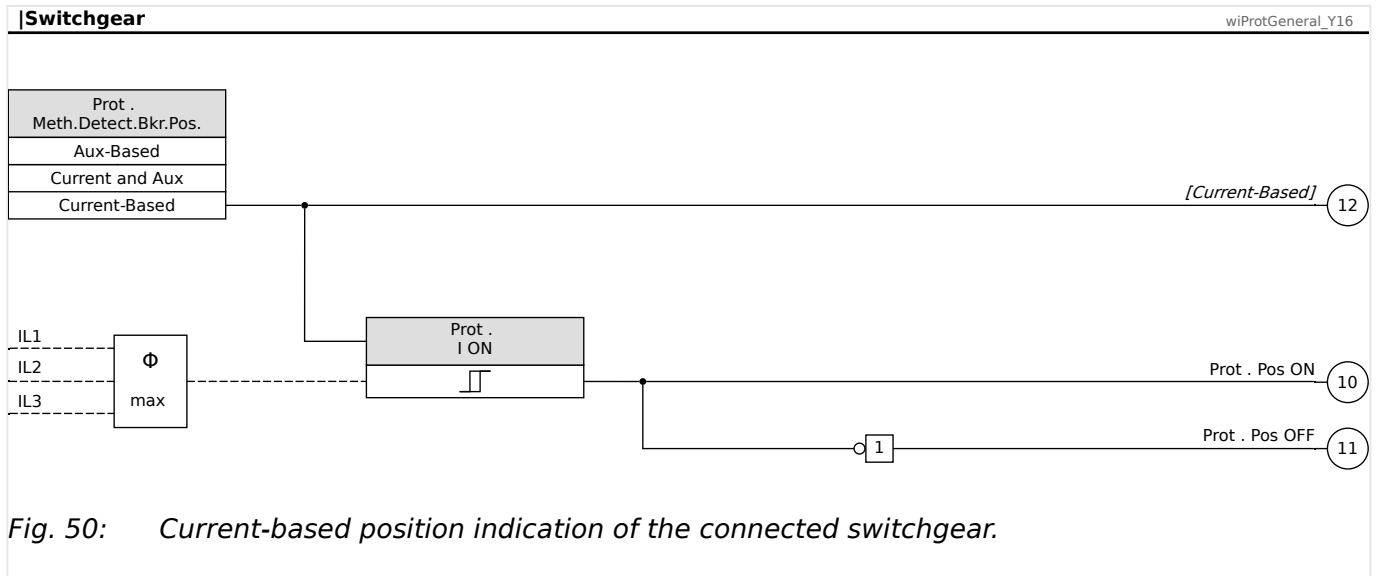
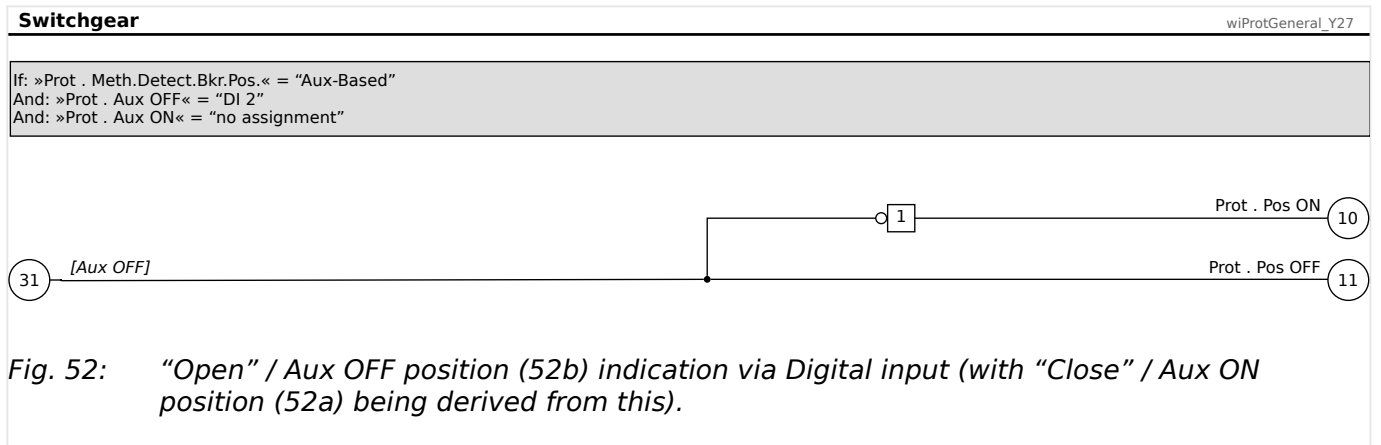
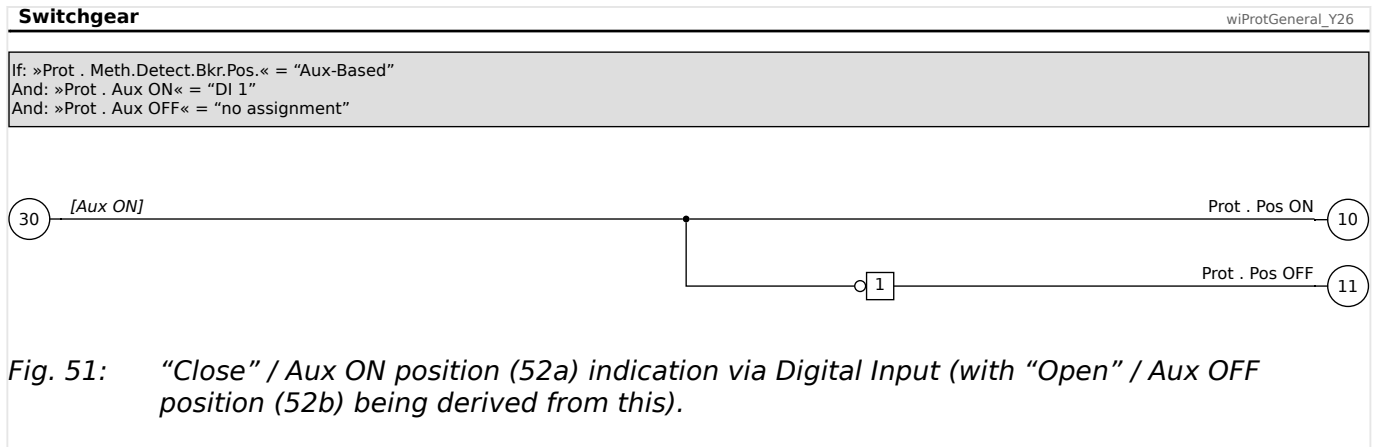

Fig. 49: Position Indication via Digital Inputs (example “DI 1”, “DI 2” with WIC1-4xxxxC).

**Position Indication, Part 1: Current-Based**



**Position Indication, Part 2: One Contact**





### Position Indication, Part 3: Current-Based and One Contact

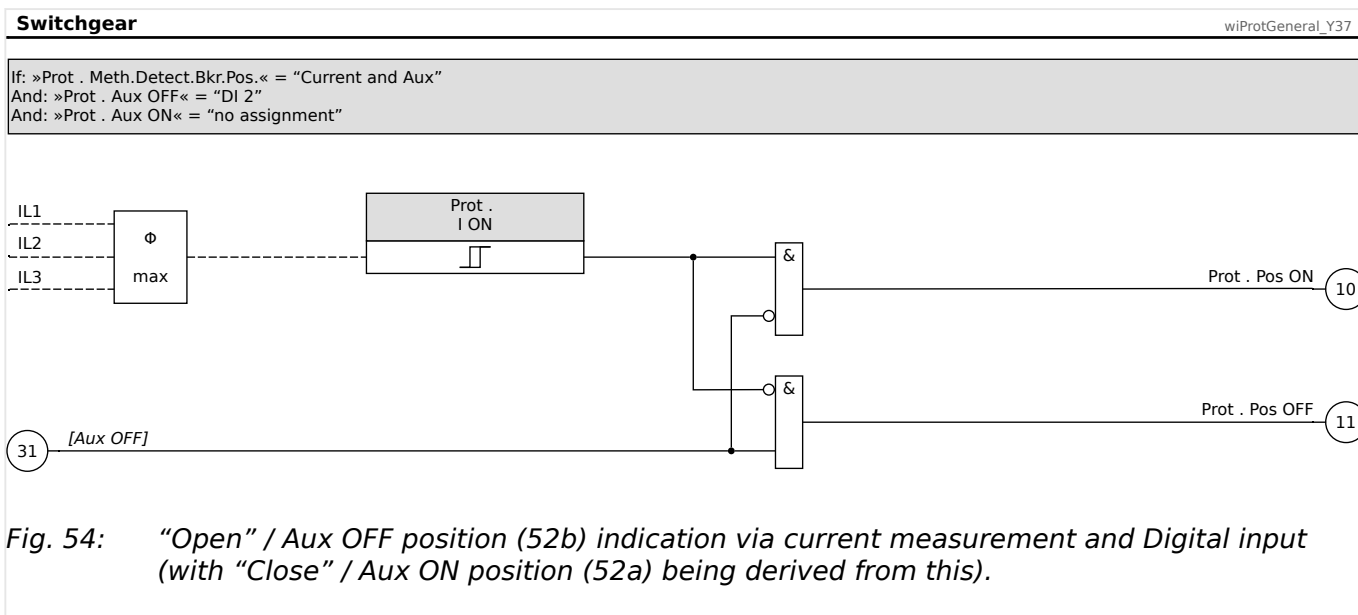
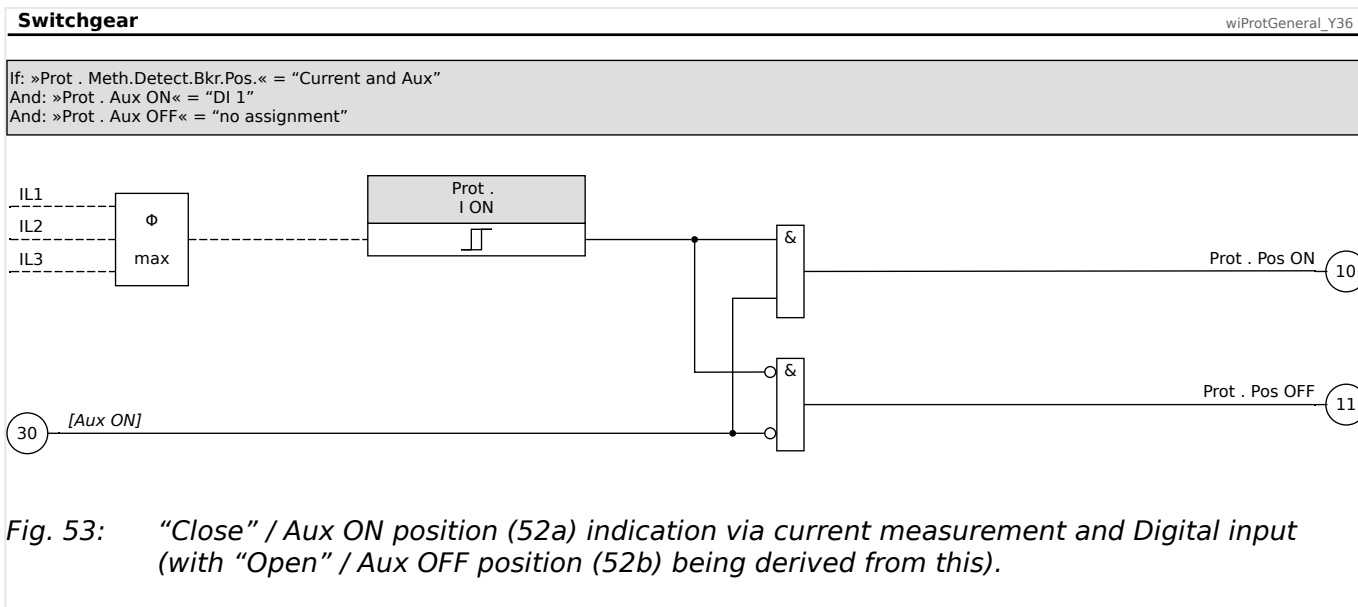

### Position Indication, Part 4: Two Contacts

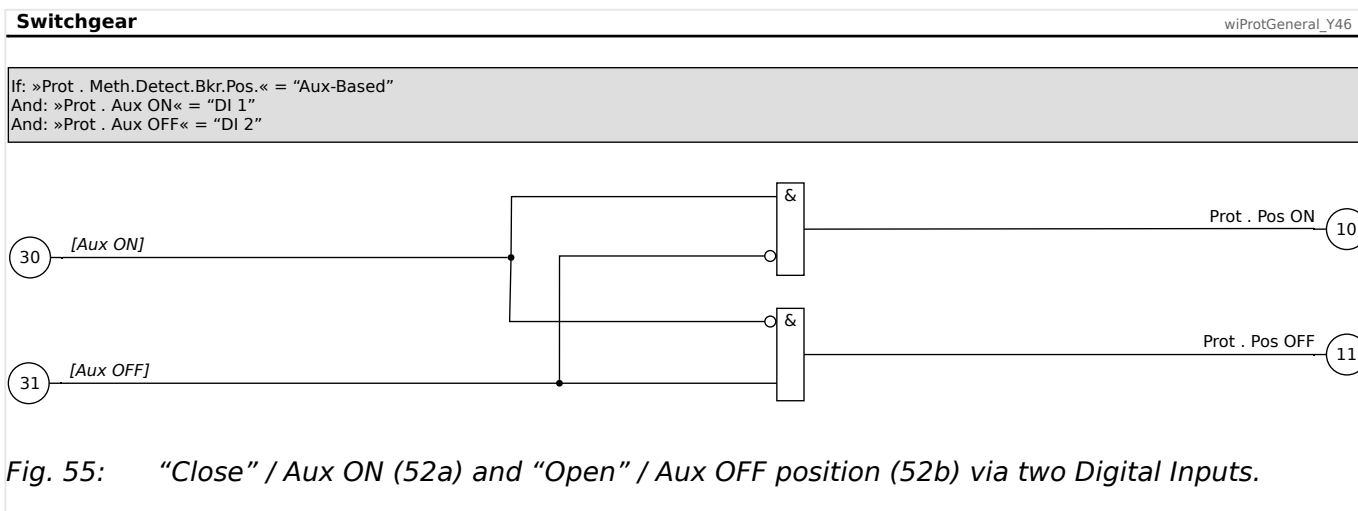

### Position Indication, Part 5: Current-Based and Two Contacts

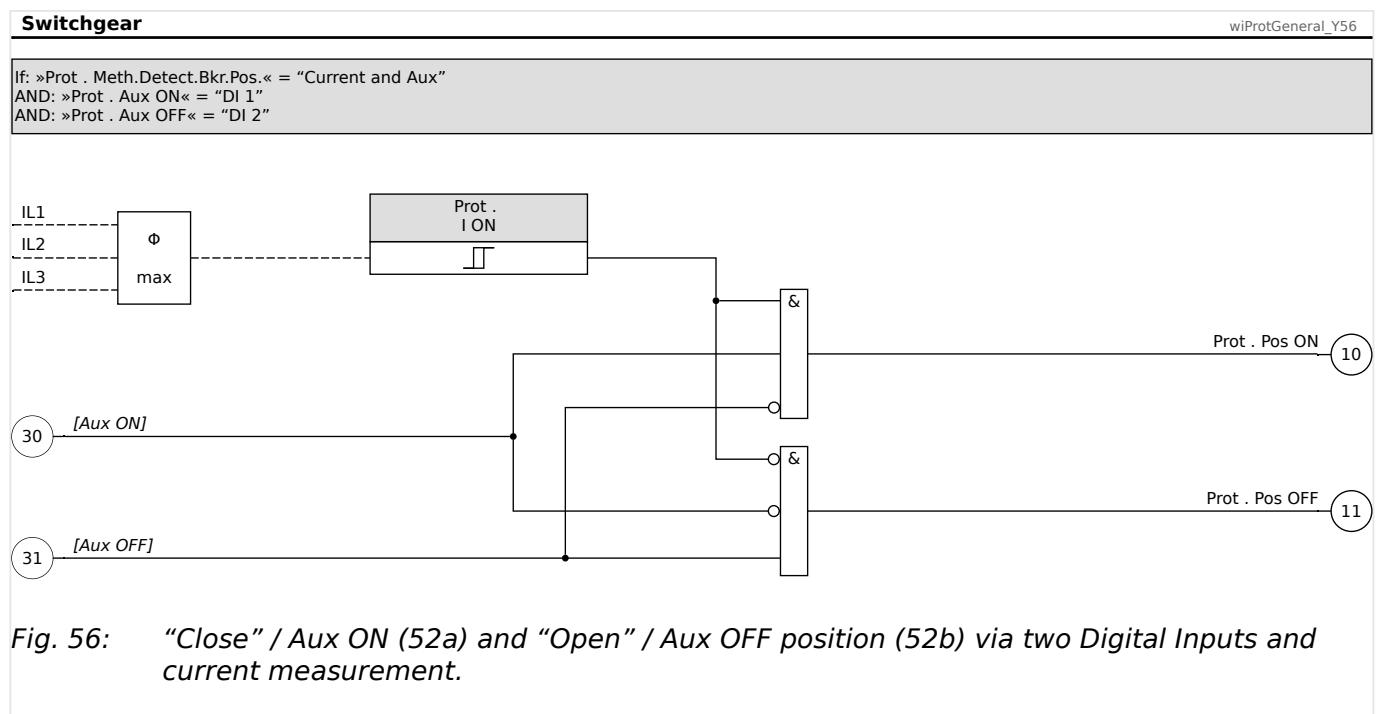

#### NOTICE!



Note that the position indication methods 3, 4, 5 shown above can result in neither signal (10) »Pos ON« nor signal (11) »Pos OFF« being active. This usually indicates an intermediate or faulty switchgear position.

## 5.2 Field Parameters

Within the field parameters you can set all parameters that are relevant for the primary side and the mains operational method.

These are in particular the setting of the rated CT current, [↪ “12.1.3 Setting of the Rated CT current In”](#), but also e. g. the nominal frequency and phase sequence, [↪ “5.2.1 Field Parameter Settings via DiggiMEC or via Smart view”](#).

All field parameters are accessible via the menu branch [Field Para].

### 5.2.1 Field Parameter Settings via DiggiMEC or via Smart view

⚙	
1. ▷	<p>Select the <b>Phase Sequence</b>:</p> <ul style="list-style-type: none"> <li>• [Field Para / General Settings] »<i>Phase Sequence</i>« =</li> </ul> <p>Options:</p> <ul style="list-style-type: none"> <li>◦ “ABC” — “rotating clockwise” phase sequence.</li> <li>◦ “ACB” — “rotating counter-clockwise” phase sequence.</li> </ul>
2. ▷	<p>Select the <b>nominal frequency</b>:</p> <ul style="list-style-type: none"> <li>• [Field Para / General Settings] »<i>f</i>« =</li> </ul> <p>Options:</p> <ul style="list-style-type: none"> <li>◦ “50” — nominal frequency <math>f_N = 50</math> Hz.</li> <li>◦ “60” — nominal frequency <math>f_N = 60</math> Hz.</li> </ul>
3. ▷	<p>Select whether the current measurement is based on the “Fundamental” or if “True RMS” measurement is used.</p> <ul style="list-style-type: none"> <li>• [Field Para / General Settings] »<i>CT . Measuring method</i>« =</li> </ul> <p>Options:</p> <ul style="list-style-type: none"> <li>◦ “Fundamental”</li> <li>◦ “True RMS”</li> </ul>
4. ▷	<p>If your WIC1 variant features a ground current measuring input, select whether the ground current protection shall operate with <b>calculated or measured</b> ground (earth) current:</p> <ul style="list-style-type: none"> <li>• [Field Para / General Settings] »<i>CT . IG Source</i>« =</li> </ul> <p>Options:</p> <ul style="list-style-type: none"> <li>◦ “calculated” — use calculated ground (earth) current.</li> <li>◦ “measured” — use measured ground (earth) current.</li> </ul>
5. ▷	<p>Specify the properties of the Current Transformers, in particular the CT type and the relative or primary rated current.</p> <ul style="list-style-type: none"> <li>• [Field Para / CT] »<i>CT . CT Type</i>« =</li> </ul> <p>Options:</p> <ul style="list-style-type: none"> <li>◦ “Relative” — Current values can only be displayed as relative values.</li> </ul>

- “WE2 : 16 A ... 56 A” ... “W6 : 256 A ... 896 A” — Current values can also be displayed as primary values, based on this CT type (and based on the primary value of the rated current set at »CT pri«, see below).
- “Standard” — Current values can also be displayed as primary values, assuming that an Adapter CTs for 1 A / 5 A is used. (See [↪ “3.3.3 Adapter CTs for 1 A / 5 A”](#). The primary value of the rated current is set at »CT pri«, see below)
- Depending on this setting, the rated current is set either as a relative current or as a primary value. (See also [↪ “2.10 Measuring Values”](#).)
  - [Field Para / CT] »CT . In,relative« — This is the relative rated current in units of [In,min], i. e. a rated current value without the CT type dependency (see [↪ “12.1.3 Setting of the Rated CT current In”](#)).
  - [Field Para / CT] »CT pri« — This is the primary value of the rated current in [A].

**6.** ▷ If a CT type has been set it is possible to set the display of current values to primary values:

- [Field Para / CT] »CT . Display of Meas. Values« =  
Options:
  - “Based on In,relative” — Current values are displayed as relative values.
  - “Primary current values” — Current values are displayed as primary values, based on the configured CT data.

**7.** ▷ If your device features a ground (earth) current measuring input, specify the properties of the Ground Current Transformers.

- [Field Para / CT] »CT . ECT pri« — the primary nominal ground current in Ampere.

## 5.3 I>, I>>, I>>> - Phase Overcurrent Protection

The Phase Overcurrent modules I>, I>>, and I>>> cover overcurrent stages, that can be set up (independently of each other) as the following protection functions:

- **DEFT** = IEEE C37.2 / ANSI 50 — Definite-Time overcurrent protection, non-directional  
Characteristic see [↳ “12.2.1.1 DEFT - Definite Time-Overcurrent \(I>, I>>, I>>>\)”](#)
- IEEE C37.2 / ANSI 51 — Inverse-Time overcurrent protection, non-directional  
Available characteristics see [↳ “12.2.1 Characteristics \(I>, I>>, I>>>\)”](#)

For general information about the concept of WIC1 protection functions, see [↳ “5.1 »Prot« - General Protection Module”](#).

### 5.3.1 Functionality

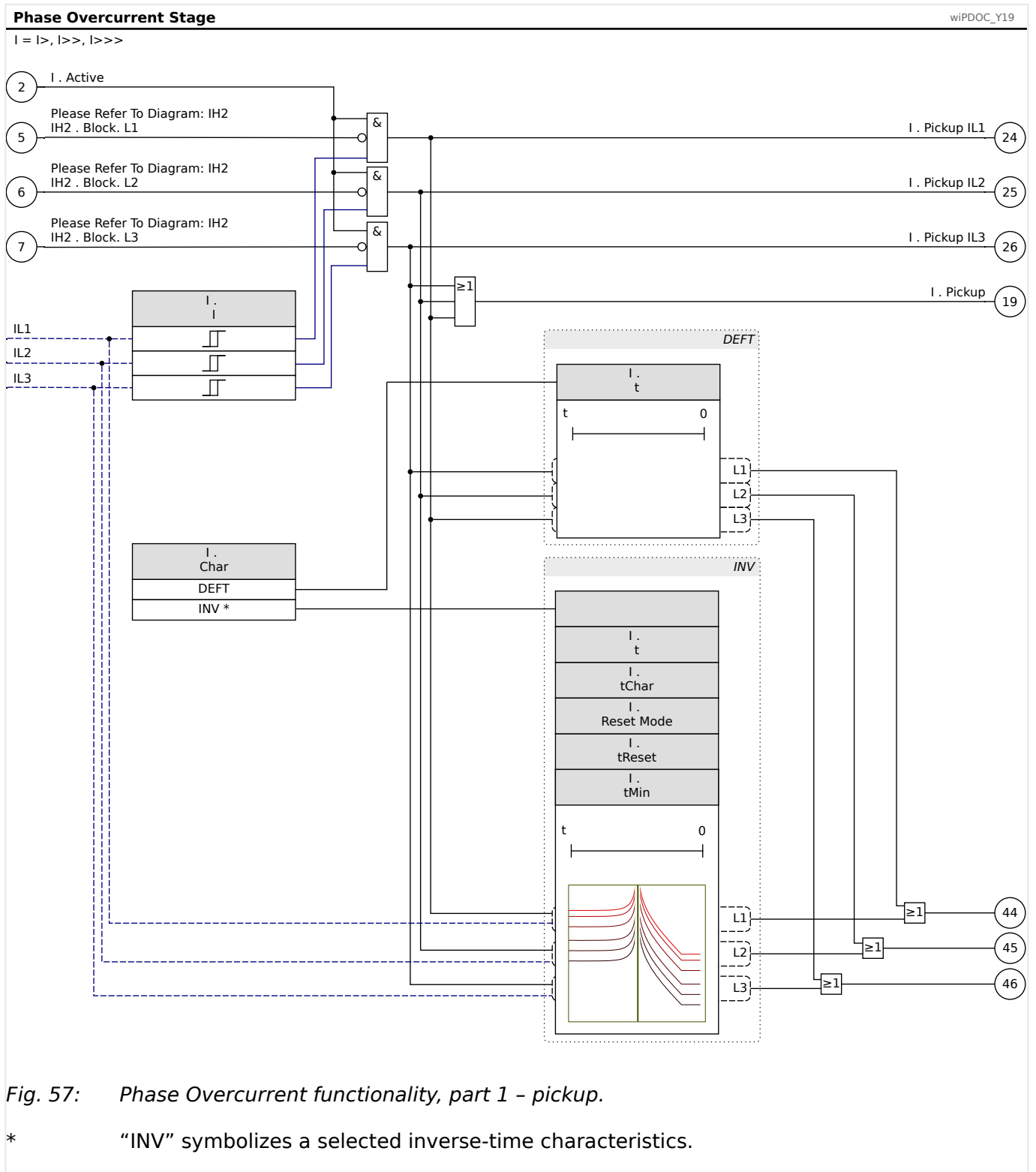

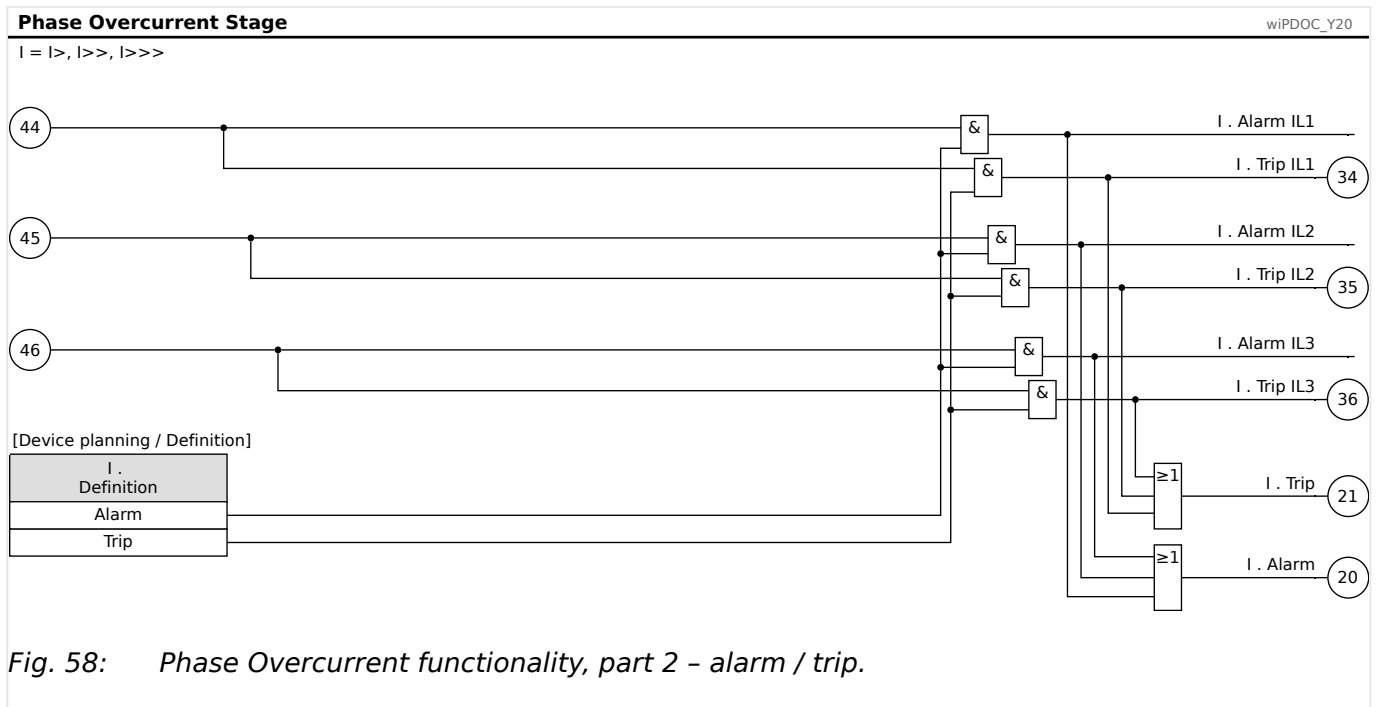

Fig. 58: Phase Overcurrent functionality, part 2 – alarm / trip.

### 5.3.2 Phase Overcurrent Protection - Settings

#### WARNING!



Ensure that the actual overcurrent settings comply with the technical and thermal limits of the device, the CTs and the application!

Check the technical data ([↪ “10.1 Technical Data - WIC1”](#)) for the permitted current input limits. When defining the protection settings, note that both current threshold and (delay) time must be set in consideration of the technical input limits.

- The thermal load capacity of the phase current inputs can be found here: [↪ “10.1.4 Phase Current Measurement”](#). The diagram and table in [↪ “3.3.2 Selection of a WIC1-Compatible Current Transformer”](#) might also be useful.
- The thermal load capacity of the ground (earth) current inputs can be found here: [↪ “10.1.5 Ground Current Measurement”](#).

Unless there are any additional/external protective means installed we have to recommend that you activate at least one phase overcurrent protection stage considering the WIC1 limits ( $2.5 \cdot I_{n,max}$  for 2.5 s, 25 kA for 1 s).

If your WIC1 features a ground (earth) current measuring input, these considerations should be applied in the same manner for one of the two ground overcurrent protection stages »/G>«, »/G>>«.

Ignoring the permitted limits will damage the WIC1, making it non-functional, and this can possibly result in serious damages of your equipment and even serious injury.

DIP/HEX switches: [↪ “12.1.4 Phase Overcurrent Protection - Settings via DIP Switches \(WIC1-2\) or via HEX Switches \(WIC1-3\)”](#)



### 5.3.2.1 Phase Overcurrent Protection - Settings via DiggiMEC or via Smart view

The following settings are listed for the example of the »I>« protection.  
For the »I>>« and »I>>>« protection stages there are the same settings and features available.



1. ▷ Activate the protection stage and select whether it shall operate as a supervision or a protection function, see [↳ “5.1 »Prot« - General Protection Module”](#).
2. ▷ Select the »I>« Phase Overcurrent **Characteristic**:
  - [Protection Para / I>] »I> . Char« =
    - Options:
      - “DEFT” (DEFinite-Time overcurrent),
      - or any of the Inverse-time characteristics listed in [↳ “12.2.1 Characteristics \(I>, I>>, I>>>\)”](#).
3. ▷ Specify the »I>« Phase Overcurrent **pickup threshold** (as a number value in units of the nominal current  $I_n$ ):
  - [Protection Para / I>] »I> . I«
4. ▷ Only in case of Definite-Time overcurrent »I> . Char« = “DEFT”:  
Specify the »I>« Phase Overcurrent **tripping delay** (in seconds):
  - [Protection Para / I>] »I> . t«
5. ▷ Select the »I>« Phase Overcurrent **Reset Mode**, that controls the reset delay:
  - [Protection Para / I>] »I> . Reset Mode« =
    - Options:
      - “instantaneous” (immediate reset),
      - “definite time” (reset delay fixed to a particular time in seconds),
      - “inverse time” (reset delay depends on the selected characteristic. This option is not available for some curves, see [↳ “12.2.1 Characteristics \(I>, I>>, I>>>\)”](#).)
6. ▷ Only in case of an Inverse-Time characteristic with fixed reset delay, »I> . Reset Mode« = “definite time”:  
Specify the »I>« Phase Overcurrent **reset delay** (in seconds):
  - [Protection Para / I>] »I> . tReset«  
(Remark: For the Definite-Time overcurrent, the reset delay always equals 0.)
7. ▷ Only in case of an Inverse-Time characteristic:  
Specify the »I>« Phase Overcurrent **minimum trip delay** (in seconds, see [↳ “Explanation for All Characteristics \(I>, I>>, I>>>\)”](#) for details):
  - [Protection Para / I>] »I> . tMin«
8. ▷ Only in case of an Inverse-Time characteristic:  
Specify the »I>« Phase Overcurrent **tripping characteristic factor** (see [↳ “Explanation for All Characteristics \(I>, I>>, I>>>\)”](#) for details):

- [Protection Para / I>] »I> . tChar«

9. ▷ If Inrush Blocking has been activated (see [↪ “5.4 IH2 - Inrush Blocking”](#)), select whether this Earth (Ground) Overcurrent stage shall be blocked in case of an inrush current:

- [Protection Para / I>] »IH2 Blo« =

Options:

- “Inactive” (no Inrush blocking of the ground overcurrent protection),
- “Active” (the Inrush Blocking module also blocks the ground overcurrent protection).

## 5.4 IH2 - Inrush Blocking

The energization of a transformer and voltage recovery cause inrush currents that can reach a multiple of the rated current, so that a pickup and even a trip of the overcurrent functions can be the result.

These pickup and trips are unwanted, and the Inrush module can prevent them (by blocking the overcurrent protection). But in case of high current faults, the situation is different: Then the Inrush blocking is unwanted because it will delay the necessary tripping: A fault with a DC offset causes a 2<sup>nd</sup> harmonic component. This can potentially result in CT saturation, especially in case of high fault currents. CT saturation increases the 2<sup>nd</sup> harmonic component furthermore. This can make the Inrush blocking module block protection stages temporarily, and in such a situation, this results in a delay of protection operation. Since the Inrush blocking is unwanted in this case the Inrush module does **not** operate if a settable threshold »*I<sub>max</sub>*« is exceeded.

The Inrush module checks for the ratio of the 2<sup>nd</sup> harmonic to the 1<sup>st</sup> harmonic and releases a blocking signal unless at least one phase current is above a settable »*I<sub>max</sub>*« threshold.

### NOTICE!



An undelayed /instantaneous overcurrent protection stage always trips earlier than the Inrush element is able to react. Therefore always use the Inrush element in combination with a small trip delay, to prevent faulty tripping, instead of undelayed/instantaneous overcurrent protection.

### **3-phase Inrush Blocking**

The amount of the 2<sup>nd</sup> harmonic can vary in each phase. It is possible that it is not high enough for an activation of inrush blocking in this phase. If it is required to avoid false tripping in such a situation the Inrush module can be set to 3-phase blocking (via setting »*IH2 . 3-ph Blo*« = "Active"). Then all three phases get blocked as soon as an inrush is detected in (at least) one phase.

### **Blocking of Protection Based on Negative-Sequence Current**

High inrush currents can lead to a transient saturation of the phase CTs. When this happens during a transformer inrush the determination of (positive and negative) sequence currents yields incorrect results. Therefore it is recommended that the Inrush blocking signal blocks all protection functions that operate on the negative-sequence current. See [↳ "5.4.2 Inrush - Settings"](#) for the settings.

### **Inrush Blocking of Ground Overcurrent Protection**

High inrush currents can lead to a transient saturation of the phase CTs. If the phase currents are used to determine the ground current (which is the case for calculated ground current), this transient saturation can result in an incorrect ground current, which can then cause a false tripping of the ground overcurrent protection.

Therefore one usually wants for these application types, that the Inrush Blocking module also blocks the ground overcurrent protection. See [↳ "5.4.2 Inrush - Settings"](#) for the settings.

### 5.4.1 Functionality

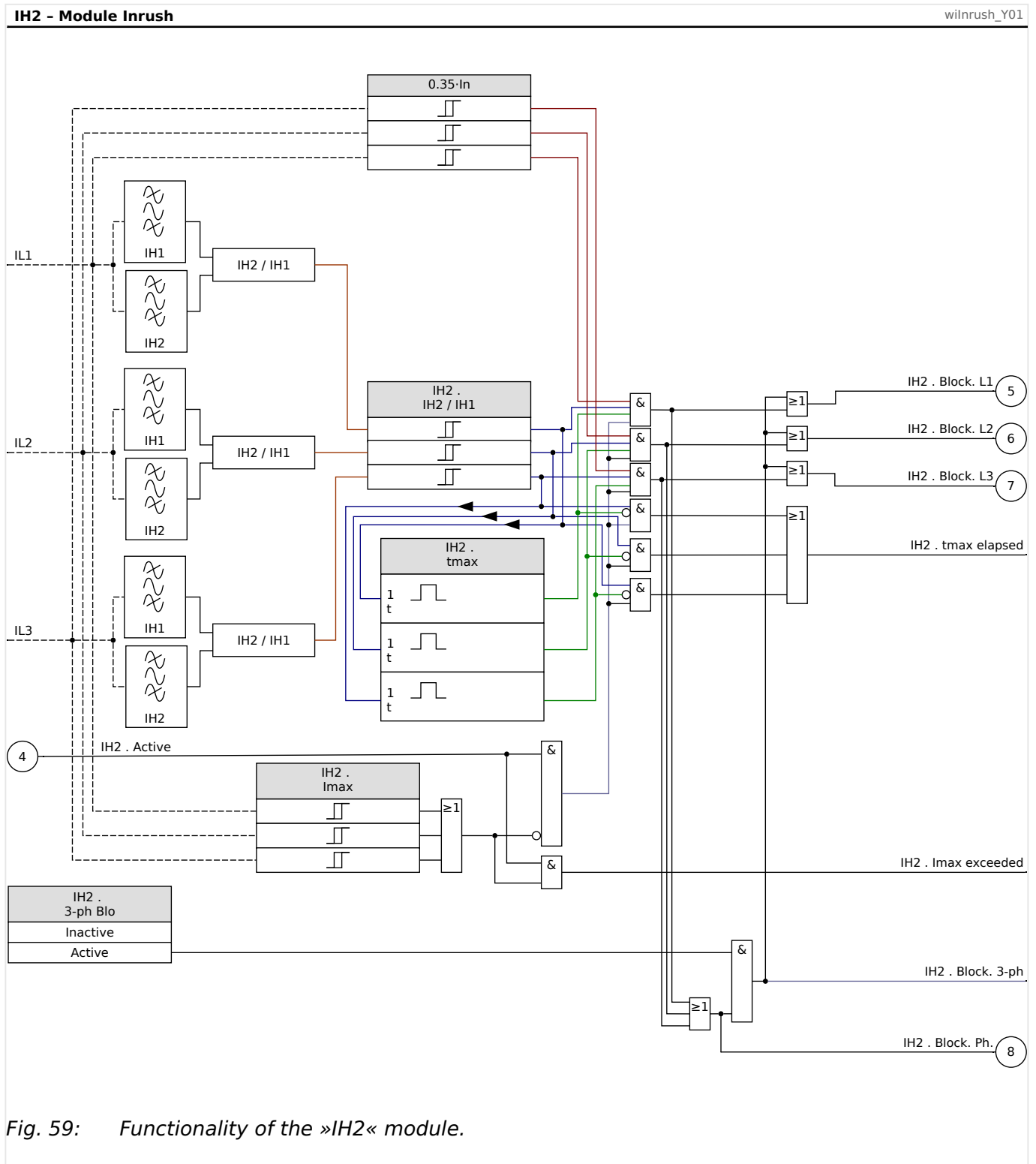

Fig. 59: Functionality of the »IH2« module.

## 5.4.2 Inrush - Settings

DIP/HEX switches:  "12.1.6 Inrush - Settings via DIP Switches (WIC1-2) or via HEX Switches (WIC1-3)"

### 5.4.2.1 Inrush - Settings via DiggiMEC or via Smart view



1. ▷ Activate the Inrush **module** »IH2«.
2. ▷ Specify the **threshold** for the ratio of the 2<sup>nd</sup> harmonic to the 1<sup>st</sup> harmonic:
  - [Protection Para / IH2] »IH2 . IH2 / IH1« — as a percentage.
3. ▷ Specify the **maximum current**, this is the upper limit for the Inrush module described [above](#):
  - [Protection Para / IH2] »IH2 . I<sub>max</sub>« — as a number value in units of the nominal current I<sub>n</sub>.
4. ▷ If required for your application, define a **maximum duration of the blocking signal**. (This is a phase-specific timer.)
  - [Protection Para / IH2] »IH2 . t<sub>max</sub>« — in seconds.

The typical duration of high inrush currents during empowering a transformer depends on its rated power. These durations have roughly the following magnitude:

- For a rated power of 0.5 MVA, approx. 0.16 s,
- for a rated power of 1 MVA, approx. 0.2 s,
- for a rated power of 10 MVA, approx. 1.2 s,
- for a rated power above 10 MVA, more than 1.2 s up to several minutes.

(Durations cited from: Gerhard Ziegler, Digitaler Differentialschutz: Grundlagen und Anwendungen, 2. Aufl. 2013).

5. ▷ Select the **block mode**:
  - [Protection Para / IH2] »IH2 . 3-ph Blo« =  
Options:
    - "Inactive" — phase-specific mode: Each phase gets blocked, for which an inrush current is detected.
    - "Active" — overall mode: All phases get blocked as soon as an inrush current is detected for at least one phase.

### 5.4.3 Commissioning: Inrush

The test procedure is dependent on the parameterized inrush-blocking-mode:

- [Protection Para / IH2] »IH2 . 3-ph Blo« = "Inactive":

For this mode, the test has to be carried out first for each individual phase and then for all three phases together.

- [Protection Para / IH2] »IH2 . 3-ph Blo« = "Active":

For this mode, the test is a three-phase one.

*Object to be tested:*

Test of inrush blocking.

*Necessary means:*

- three-phase current source with adjustable frequency,
- three-phase current source (for the first harmonic).

The current sources need to be connected in parallel.

*Procedure (dependent on the parameterized blocking mode):*

- It is recommended to set »IH2 . tmax« (temporarily) to a value that is large enough to manually check the Inrush blocking signals within the menu [Operation / Status Display / IH2].
- Feed the current to the secondary side with nominal frequency.
- Feed abruptly current to the secondary side with double nominal frequency. The amplitude must exceed the preset ratio/threshold »IH2 . IH2 / IH1«, but must not exceed the maximum current »IH2 . Imax«.
- Ascertain that the corresponding Inrush blocking signal is generated now: »IH2 . Block. L1«, »IH2 . Block. L2«, »IH2 . Block. L3«

*Successful test results:*

The corresponding Inrush blocking signal is generated and can be checked at [Operation / Status Display / IH2], indicating the blocking of the current protection stage.

## 5.5 IG>, IG>> - Earth (Ground) Overcurrent Protection

The Earth (Ground) Overcurrent modules »IG>«, »IG>>« can be set up as any of the following [protection functions](#):

- [DEFT](#) = IEEE C37.2 / ANSI 50N/G — Definite-Time ground (earth) overcurrent protection, non-directional (see also [↪](#) “12.2.2.1 DEFT - Definite Time-Overcurrent (IG>, IG>>)”).
  - IEEE C37.2 / ANSI 50N is based on calculated ground (earth) current and always available,
  - IEEE C37.2 / ANSI 50G is based on measured ground (earth) current, and is available for WIC1 variants with ground/earth measuring input. (See [↪](#) “2.6.1 Order Form of the Device”.)
- IEEE C37.2 / ANSI 51N/G — Inverse-Time ground (earth) overcurrent protection, non-directional (characteristics see [↪](#) “12.2.2 Characteristics (IG>, IG>>)”).
  - IEEE C37.2 / ANSI 51N is based on calculated ground (earth) current and always available,
  - IEEE C37.2 / ANSI 51G is based on measured ground (earth) current, and is available for WIC1 variants with ground/earth measuring input. (See [↪](#) “2.6.1 Order Form of the Device”.)

For general information about the concept of WIC1 protection functions, see [↪](#) “5.1 »Prot« - General Protection Module”.

### 5.5.1 Functionality

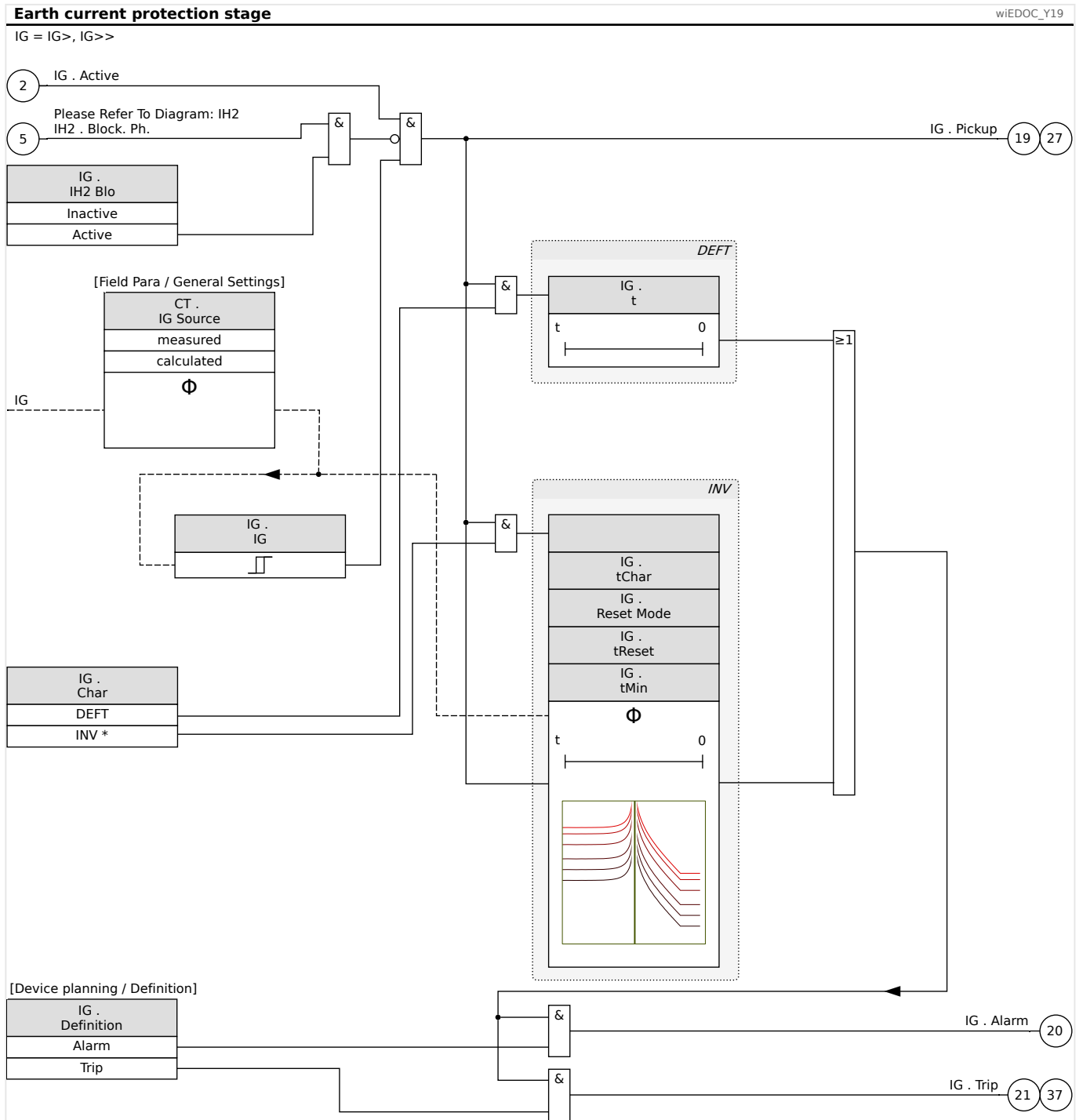

Fig. 60: Functionality of the ground (earth) overcurrent stages.

\* "INV" symbolizes a selected inverse-time characteristics.



## 5.5.2 Earth (Ground) Overcurrent Protection - Settings

### WARNING!



In case of measured ground (earth) current:

Ensure that the actual overcurrent settings comply with the technical and thermal limits of the device, the CTs and the application!

Check the technical data ([↪ “10.1 Technical Data - WIC1”](#)) for the permitted value ranges. When defining the ground overcurrent protection settings, note that both threshold and (delay) time must be set in consideration of the technical current input limits.

- The thermal load capacity of the ground (earth) current inputs can be found here: [↪ “10.1.5 Ground Current Measurement”](#).

Unless there are any additional/external protective means installed we have to recommend that you activate at least one ground overcurrent protection stage considering the WIC1 limits.

Ignoring the permitted limits results will damage the WIC1, making it non-functional, and this can possibly result in serious damages of your equipment and even serious injury.

### NOTICE!



The „nominal current“ (rated current)  $I_n$  is for all Earth (Ground) Overcurrent stages dependent on whether the ground (earth) current is measured or calculated. This is especially true of all settings parameters that are defined in units of  $I_n$ .

- Measured ground (earth) current, [Field Para / General Settings] »CT . IG Source« = “measured”:

$I_n$  is the rated current of the ground (earth) CT, and the WIC1 currently supports 1 A ground (earth) CTs.

- Calculated ground (earth) current, [Field Para / General Settings] »CT . IG Source« = “calculated”:

$I_n$  is the rated current of the phase CTs, and this corresponds to the setting [Field Para / CT] »CT . In,relative«. (See also [↪ “12.1.3 Setting of the Rated CT current In”](#) and [↪ “5.2 Field Parameters”](#).)

DIP/HEX switches: [↪ “12.1.5 Earth \(Ground\) Overcurrent Protection - Settings via DIP Switches \(WIC1-2\) or via HEX Switches \(WIC1-3\)”](#)

### 5.5.2.1 Earth (Ground) Overcurrent Protection – Settings via DiggiMEC or via Smart view

The following settings are listed for the example of the »IG>« protection. For the »IG>>« protection stage there are the same settings and features available.

⚙	
1. ▷	Make sure all Field Parameters are set. In particular for ground (earth) overcurrent protection, select between calculated or measured ground current. See <a href="#">↳ “5.2 Field Parameters”</a> .
2. ▷	Activate the protection stage and select whether it shall operate as a supervision or a protection function, see <a href="#">↳ “5.1 »Prot« – General Protection Module”</a> .
3. ▷	Select the »IG>« Earth (Ground) Overcurrent <b>Characteristic</b> : <ul style="list-style-type: none"> <li>• [Protection Para / IG&gt;] »IG&gt; . Char« =</li> <li>Options: <ul style="list-style-type: none"> <li>◦ “DEFT” (DEFinite-Time overcurrent),</li> <li>◦ or any of the Inverse-time characteristics listed in <a href="#">↳ “12.2.2 Characteristics (IG&gt;, IG&gt;&gt;)”</a>.</li> </ul> </li> </ul>
4. ▷	Specify the »IG>« Earth (Ground) Overcurrent <b>pickup threshold</b> (as a number value in units of the nominal current $I_n$ ): <ul style="list-style-type: none"> <li>• [Protection Para / IG&gt;] »IG&gt; . IG«</li> </ul>
5. ▷	Only in case of Definite-Time overcurrent »IG> . Char« = “DEFT”: Specify the »IG>« Earth (Ground) Overcurrent <b>tripping delay</b> (in seconds): <ul style="list-style-type: none"> <li>• [Protection Para / IG&gt;] »IG&gt; . t«</li> </ul>
6. ▷	Select the »IG>« Earth (Ground) Overcurrent <b>Reset Mode</b> , that controls the reset delay: <ul style="list-style-type: none"> <li>• [Protection Para / IG&gt;] »IG&gt; . Reset Mode« =</li> <li>Options: <ul style="list-style-type: none"> <li>◦ “instantaneous” (immediate reset),</li> <li>◦ “definite time” (reset delay fixed to a particular time in seconds),</li> <li>◦ “inverse time” (reset delay depends on the selected characteristic. This option is not available for some curves, see <a href="#">↳ “12.2.2 Characteristics (IG&gt;, IG&gt;&gt;)”</a>.)</li> </ul> </li> </ul>
7. ▷	Only in case of an Inverse-Time characteristic with fixed reset delay, »IG> . Char« = “definite time”: Specify the »IG>« Earth (Ground) Overcurrent <b>reset delay</b> (in seconds): <ul style="list-style-type: none"> <li>• [Protection Para / IG&gt;] »IG&gt; . tReset«</li> <li>(Remark: For the Definite-Time overcurrent, the reset delay always equals 0.)</li> </ul>
8. ▷	Only in case of an Inverse-Time characteristic: Specify the »IG>« Earth (Ground) Overcurrent <b>minimum trip delay</b> (in seconds, see <a href="#">↳ “Explanation for All Characteristics (IG&gt;, IG&gt;&gt;)”</a> for details): <ul style="list-style-type: none"> <li>• [Protection Para / IG&gt;] »IG&gt; . tMin«</li> </ul>

**9.** ▷ Only in case of an Inverse-Time characteristic:  
Specify the »IG<« Earth (Ground) Overcurrent **tripping characteristic factor** (see [↗](#) “Explanation for All Characteristics (IG>, IG>>)” for details):

- [Protection Para / IG>] »IG> . tChar«

**10.** ▷ If Inrush Blocking has been activated (see [↗](#) “5.4 IH2 - Inrush Blocking”), select whether this Earth (Ground) Overcurrent stage shall be blocked in case of an inrush current:

- [Protection Para / IG>] »IH2 Blo« =  
Options:
  - “Inactive” (no Inrush blocking of the ground overcurrent protection),
  - “Active” (the Inrush Blocking module also blocks the ground overcurrent protection).

## 5.6 I2/I1> - Unbalanced Load [46]

The protection function »I2/I1>« is similar to the Phase Overcurrent protection. The main difference is that the Phase Overcurrent protection monitors the three phase currents, whereas the »I2/I1>« module monitors the negative-sequence current I2 (in comparison with the positive-sequence current I1).

- IEEE C37.2 / ANSI 46 — Unbalanced Load Protection.

For general information about the concept of WIC1 protection functions, see [↪](#) “5.1 »Prot« - General Protection Module”.

### NOTICE!



High inrush currents can lead to a transient saturation of the phase CTs. When this happens during a transformer inrush the determination of (positive and negative) sequence currents yields incorrect results.

### 5.6.1 Functionality

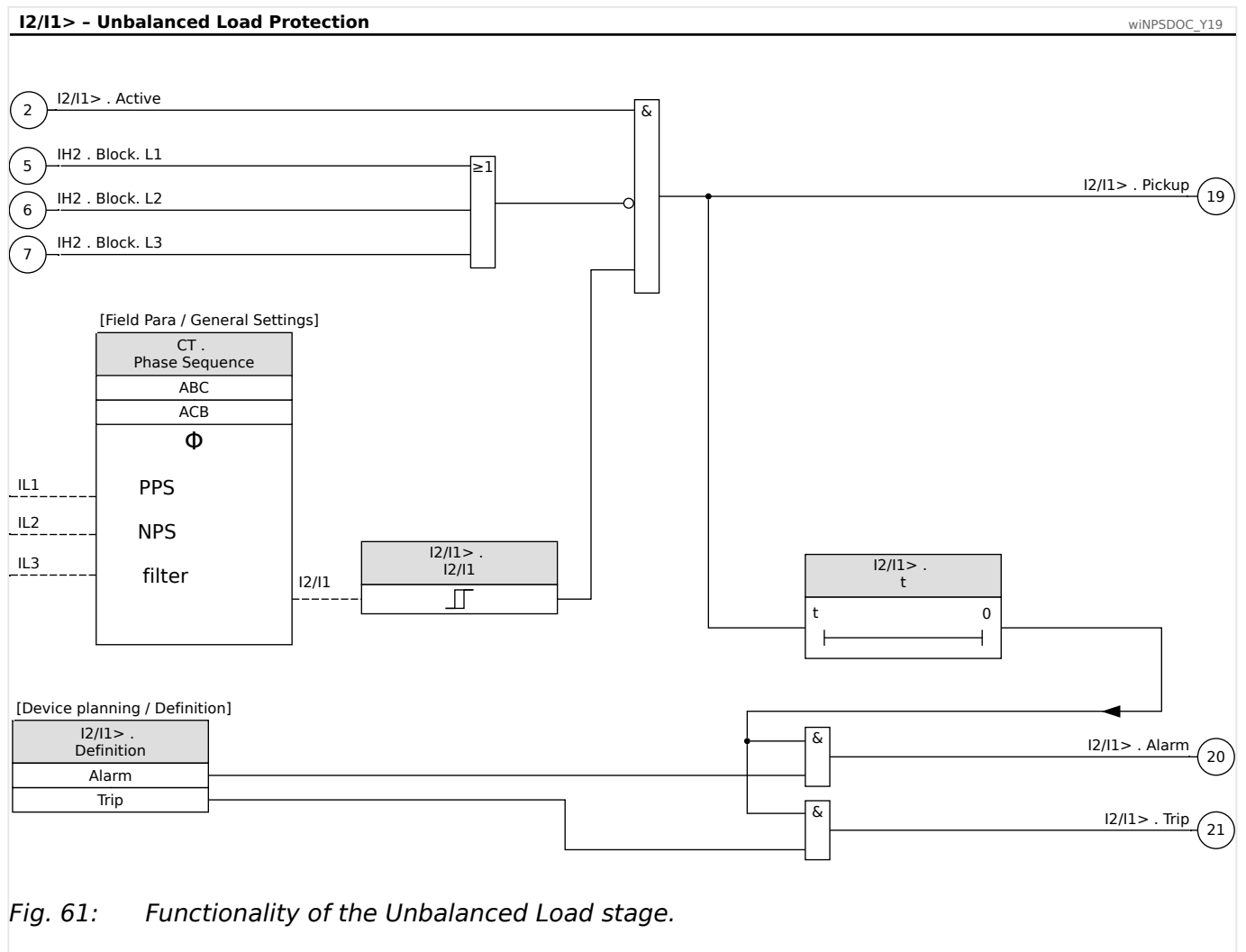



Fig. 61: Functionality of the Unbalanced Load stage.

### 5.6.2 Current Unbalance Protection - Settings via DiggiMEC or via Smart view

	
<b>1.</b> ▷	Activate the protection stage and select whether it shall operate as a supervision or a protection function, see <a href="#">↪</a> “5.1 »Prot« - General Protection Module”.
<b>2.</b> ▷	Specify the »I2/I1>« <b>pickup threshold</b> : <ul style="list-style-type: none"><li>• [Protection Para / I2/I1&gt;] »I2/I1&gt; . I2/I1« — as a percentage.</li></ul>
<b>3.</b> ▷	Specify the <b>tripping delay</b> (in seconds): <ul style="list-style-type: none"><li>• [Protection Para / I2/I1&gt;] »I2/I1&gt; . t«</li></ul>
<b>4.</b> ▷	If Inrush Blocking has been activated (see <a href="#">↪</a> “5.4 IH2 - Inrush Blocking”), select whether this Earth (Ground) Overcurrent stage shall be blocked in case of an inrush current: <ul style="list-style-type: none"><li>• [Protection Para / I2/I1&gt;] »IH2 Blo« = Options:<ul style="list-style-type: none"><li>◦ “Inactive” (no Inrush blocking of the ground overcurrent protection),</li><li>◦ “Active” (the Inrush Blocking module also blocks the ground overcurrent protection).</li></ul></li></ul>

## 5.7 I2> - Negative-Sequence Current Protection [51Q]

The protection function »I2>« is similar to the Phase Overcurrent protection. The main difference is that the Phase Overcurrent protection monitors the three phase currents, whereas the »I2>« module monitors the negative-sequence current I2.

- IEEE C37.2 / ANSI 51Q — Negative-Sequence Current Protection,  
available characteristics see [↪ “12.2.3 Characteristics »I2>«”](#).

For general information about the concept of WIC1 protection functions, see [↪ “5.1 »Prot« - General Protection Module”](#).

### NOTICE!



High inrush currents can lead to a transient saturation of the phase CTs. When this happens during a transformer inrush the determination of (positive and negative) sequence currents yields incorrect results.

### 5.7.1 Functionality

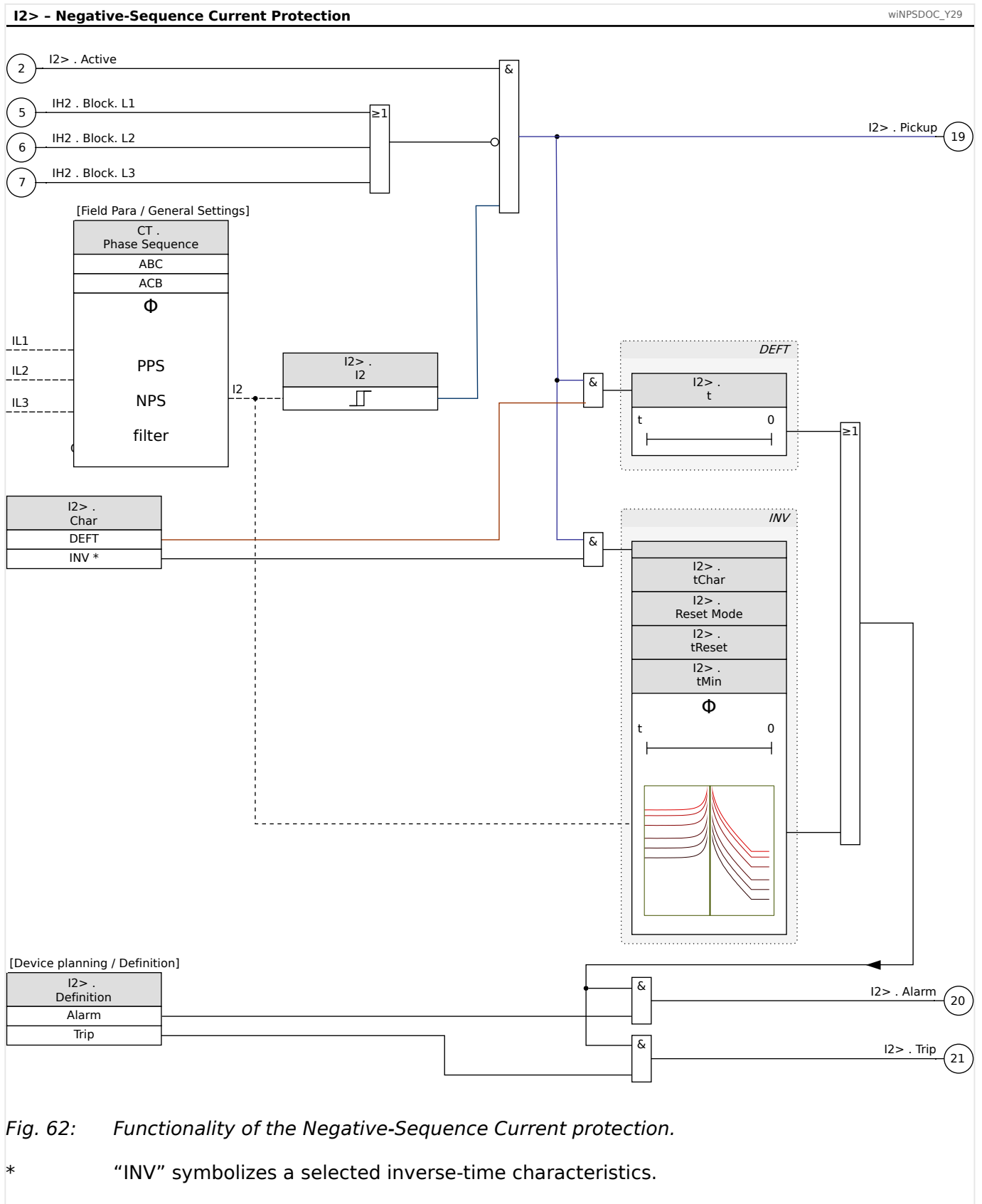



## 5.7.2 Settings via DigiMEC or via Smart view



1. ▷ Activate the protection stage and select whether it shall operate as a supervision or a protection function, see [↳ “5.1 »Prot« – General Protection Module”](#).
2. ▷ Select the **Characteristic**:
  - [Protection Para / I2>] »I2> . Char« =  
Options:
    - “DEFT” (DEFinite-Time),
    - or any of the Inverse-time characteristics listed in [↳ “12.2.3 Characteristics »I2>«”](#).
3. ▷ Specify the **pickup threshold**:
  - [Protection Para / I2>] »I2> . I2 — as a number value in units of the nominal current In.
4. ▷ Only in case of the Definite-Time characteristic »I2> . Char« = “DEFT”:  
Specify the **tripping delay** (in seconds):
  - [Protection Para / I2>] I2> . t«
5. ▷ Only in case of an Inverse-Time characteristic, select the **Reset Mode**, that controls the reset delay:
  - [Protection Para / I2>] »I2> . Reset Mode« =  
Options:
    - “instantaneous” (immediate reset),
    - “definite time” (reset delay fixed to a particular time in seconds),
    - “inverse time” (reset delay depends on the selected characteristic. This option is not available for some curves, see [↳ “12.2.3 Characteristics »I2>«”](#).)
6. ▷ Only in case of an Inverse-Time characteristic with fixed reset delay, »I2> . Reset Mode« = “definite time”:  
Specify the **reset delay** (in seconds):
  - [Protection Para / I2>] »I2> . tReset«  
(Remark: For the Definite-Time overcurrent, the reset delay always equals 0.)
7. ▷ Only in case of an Inverse-Time characteristic:  
Specify the **minimum trip delay** (in seconds, see [↳ “Explanation for All Characteristics \(»I2>«\)”](#) for details):
  - [Protection Para / I2>] »I2> . tMin«
8. ▷ Only in case of an Inverse-Time characteristic:  
Specify the **tripping characteristic factor** (see [↳ “Explanation for All Characteristics \(»I2>«\)”](#) for details):
  - [Protection Para / I2>] »I2> . tChar«

**9.** ▷ If Inrush Blocking has been activated (see [↳ “5.4 IH2 - Inrush Blocking”](#)), select whether this Earth (Ground) Overcurrent stage shall be blocked in case of an inrush current:

- [Protection Para / I2>] »IH2 Blo« =

Options:

- “Inactive” (no Inrush blocking of the ground overcurrent protection),
- “Active” (the Inrush Blocking module also blocks the ground overcurrent protection).

## 5.8 ThR - Thermal Overload [49]

The thermal overload protection »ThR« protects the connected object against overload.

The amount of overload is determined based on the measured RMS phase currents. The thermal overload module »ThR« provides two different overload warning levels:

- The Pre-Alarm level is settable via »*Pre-Alarm Lev.*« between 50% and 100% and issues a Pre-Alarm signal if the set value is exceeded.
- The Trip level is fixed at 100%. If this level is reached a Pickup signal and either a Trip (Operate) or an Alarm signal are issued.

The WIC1 calculates the thermal load of the equipment by using the existing measured values and the parameter settings. When knowing the thermal constants, the temperature of the equipment can be established (simulated).

The thermal level is reset to zero in any of the following cases:

- a change of the configuration (i. e. changed settings / parameters);
- as soon as the thermal overload module is deactivated (signal »ThR . Active« = "False").
- manually, via the Direct Control [Operation / Reset] »*Rst. Thermal Lev.*«.

### **Tripping Time**

The general tripping times of the overload protection can be gathered from the following equation:

$$t = \tau\text{-warm} \cdot \ln\left(\frac{I^2 - I_p^2}{I^2 - (K \cdot I_b)^2}\right)$$

Legend:

- t = tripping delay
- $\tau\text{-warm}$  = warming-up time constant
- $\tau\text{-cool}$  = cooling time constant
- $I_b$  = base current: maximum permissible thermal continuous current
- K = overload factor: The maximum thermal limit is defined as  $K \cdot I_b$ , the product of the overload factor and the base current.
- I = measured current (in units of In)
- $I_p$  = preload current

### 5.8.1 Functionality

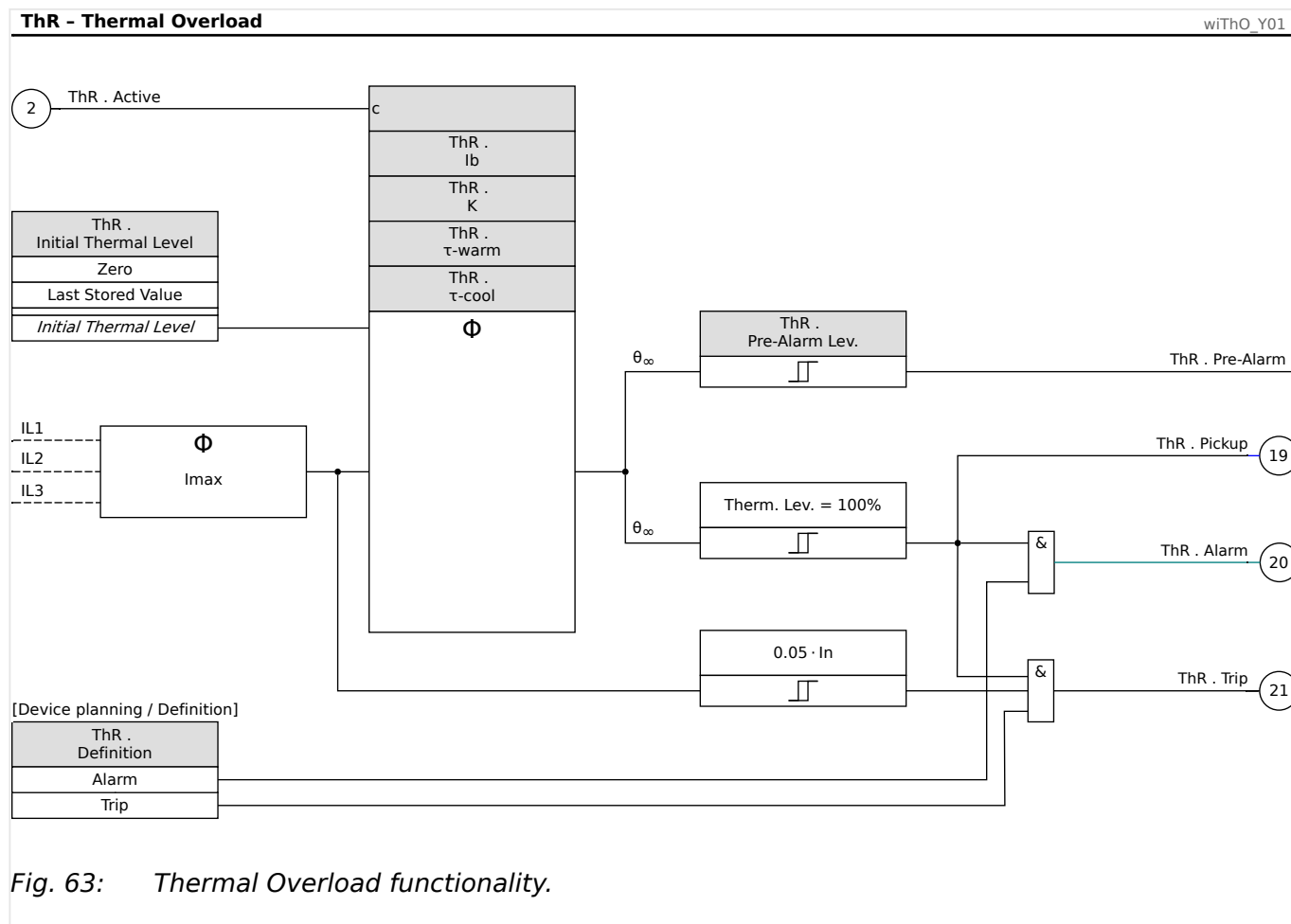

Fig. 63: Thermal Overload functionality.

## 5.8.2 Thermal Overload – Settings via DiggiMEC or via Smart view



1. ▷ Activate the protection stage and select whether it shall operate as a supervision or a protection function, see [↳ “5.1 »Prot« – General Protection Module”](#).
2. ▷ Specify the **base current**. This is the maximum permissible thermal continuous current:
  - [Protection Para / ThR] »ThR . Ib« — as a number value in units of the nominal current In.
3. ▷ Specify the **Overload Factor**. This is a number without unit, and when it is multiplied with the base current then the result is the maximum thermal limit:
  - [Protection Para / ThR] »ThR . K« — as a number value without a unit.
4. ▷ Specify the **warming-up time constant** and the **cooling time constant**:
  - [Protection Para / ThR] »ThR .  $\tau$ -warm« — as a time value in seconds.
  - [Protection Para / ThR] »ThR .  $\tau$ -cool« — as a time value in seconds.
5. ▷ Specify the **Pre-Alarm level** (see the description at the beginning of this chapter):
  - [Protection Para / ThR] »ThR . Pre-Alarm Lev.« — as a percentage.
6. ▷ Select a **criterion** that defines the initial value of the thermal capacity in case of a device restart:
  - [Protection Para / ThR] »ThR . Initial Thermal Level« =  
Options:
    - “Zero” — The initial value is set to zero.
    - “Last Stored Value” — The initial value is set to the last known value but limited to max. 95%. (Without the limit, a restart after a thermal trip, i. e. a trip with  $\theta \geq 100\%$ , would use an initial value  $\geq 100\%$ , so that the Thermal Overload protection would immediately trip again.)

## 5.9 Ipeak> - Peak Overcurrent Protection

The Peak Overcurrent module »Ipeak>« is aiming at extremely short detection and operating times (approx.  $\frac{1}{2}$  period). It is primarily used for detecting a switching onto an earthing and short-circuiting device, and therefore it is generally used in combination with the Switch Onto Fault ([SOTF](#)) protection.

It monitors unfiltered phase current measurement values and checks whether these exceed a particular peak threshold, and this way very fast tripping times can be achieved. But on the other hand, there is no suppression of the DC component and no suppression of harmonics.

The »Ipeak>« is useful if and only if the following aspects are essential for the application:

- A very fast tripping time is the top priority (instead of all other aspects, especially those requiring a Fourier filtering).
- The peak threshold is far above the inrush current (because it is not possible to block this protection stage by an [Inrush Blocking](#)).

In case of different requirements / priorities, you should consider using the [Phase Overcurrent](#) protection instead.

For general information about the concept of WIC1 protection functions, see [↪](#) “5.1 »Prot« – General Protection Module”.

### 5.9.1 Functionality

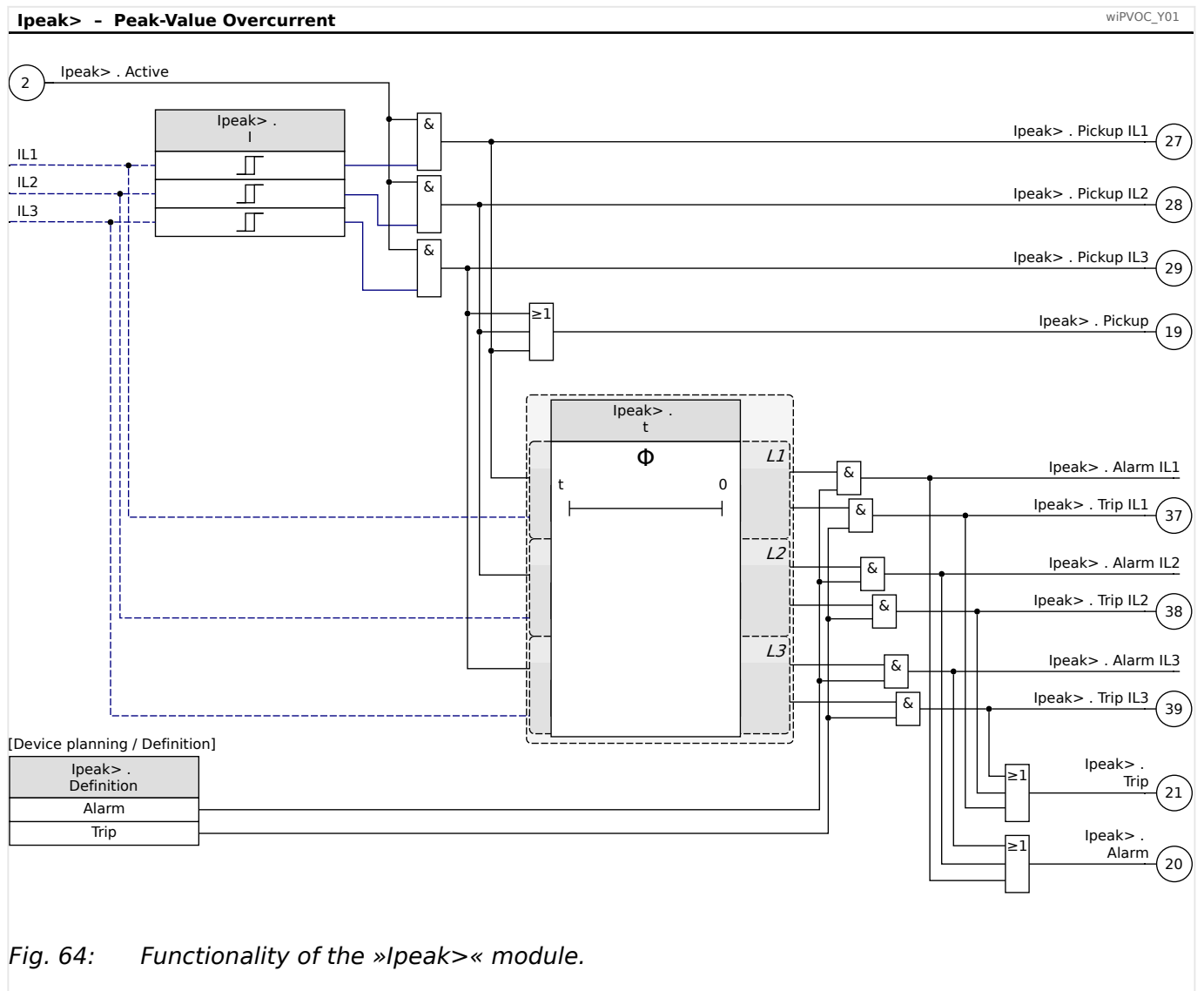

## 5.9.2 Ipeak> - Settings

DIP/HEX switches: [↪](#) “12.1.7 Ipeak> - Settings via DIP Switches (WIC1-2) or via HEX Switches (WIC1-3)”

### 5.9.2.1 Ipeak> - Settings via DiggiMEC or via Smart view



1. ▷ Activate the protection stage and select whether it shall operate as a supervision or a protection function, see [↪](#) “5.1 »Prot« - General Protection Module”.
2. ▷ Select between **Supervision only** or protection tripping:
  - [Device planning / Definition] »Ipeak> . Definition« =  
Options:
    - “Alarm” — In case of a detected overcurrent, the module issues only an alarm signal »Ipeak> . Alarm . Alarm« but does not trip the circuit breaker.
    - “Trip” — In case of a detected overcurrent, the module issues a trip signal »Ipeak> . Trip and trips the circuit breaker.
3. ▷ Specify the **pickup threshold**:
  - [Protection Para / Ipeak>] »Ipeak> . I« — as a number value in units of the nominal current  $I_n$ .  
Note that the device has an internal factor of  $\sqrt{2}$  due to its use of peak values: A setting value of, for instance,  $8 \cdot I_n$  means a pickup at a current value  $|i(t)| \geq \sqrt{2} \cdot 8 \cdot I_n$ .
4. ▷ Specify the **tripping delay** (in seconds):
  - [Protection Para / Ipeak>] »Ipeak> . t«  
Note, however, that due to the general concept of this protection module, only an instantaneous tripping ( $\text{»Ipeak> . t«} = 0$ ) makes sense in most applications.



## 5.10 SOTF - Switch Onto Fault

In case a faulty line is energized (e. g. when an earthing switch is in closed position), an instantaneous trip is recommended. The »SOTF« module is active only for a limited period of time after some selectable condition is fulfilled:

- With the setting »Enabling« = "Close Command": activation of SOTF after the circuit breaker has been closed manually.

The close command is recognized based on the (rising edge of the) signal »Prot . SCmd ON«.

- With the setting »Enabling« = "Breaker Pos.": activation of SOTF with the OPENED position of the circuit breaker, and the activation continues until the OPENED position drops off, plus the timer setting »SOTF . t-enable«. (The breaker positions are determined according to the principles described in [↩➤ "Criteria for Determining the Switchgear Position".](#))

A device restart also activates SOTF.

In the special case of a WIC1-4 with external power supply and current-based position determination, the CLOSED state is accepted as a SOTF activation only after the circuit breaker had been OPENED for at least 3 minutes. (This duration is a fixed device-internal time.)

Depending on the setting of »Trigger«, the SOTF condition is recognized by a pickup signal from one of the [phase overcurrent](#) modules or from the [peak overcurrent](#) module, or by a [\(general\) protection pickup](#).

**Functionality of the »SOTF« Module**

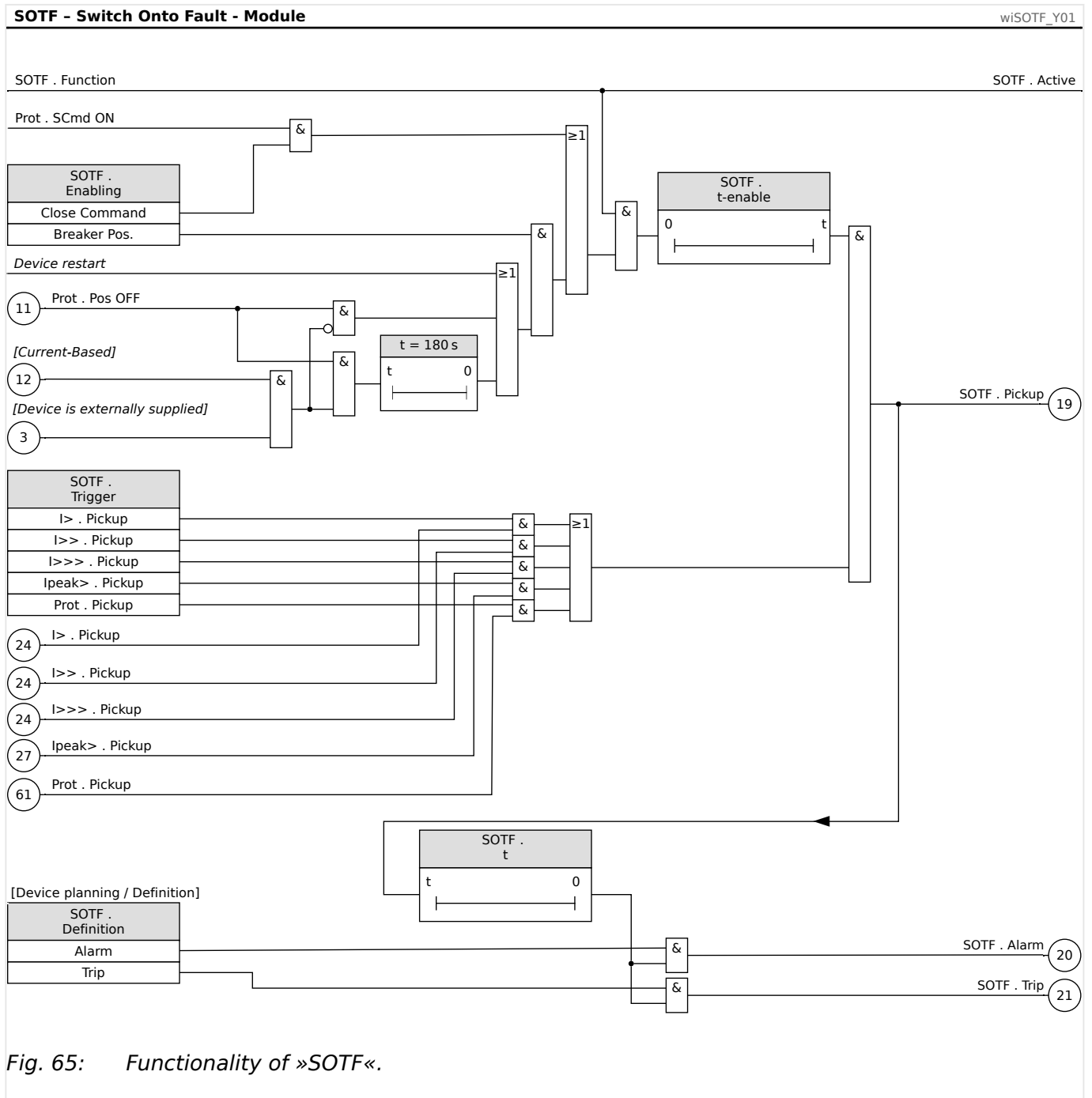

### 5.10.1 SOTF - Settings via DigiMEC or via Smart view



1. ▷ Activate the protection stage and select whether it shall operate as a supervision or a protection function, see [↳ “5.1 »Prot« - General Protection Module”](#).
2. ▷ Set the **activating condition**, as described [at the beginning of this chapter](#):
  - [Protection Para / SOTF] »SOTF . Enabling« =  
Available options depend on device variant:
    - “Close Command”, “Breaker Pos.”.
3. ▷ Set the **trigger mode** by selecting which pickup signal shall trigger the »SOTF« module:
  - [Protection Para / SOTF] »SOTF . Trigger« =  
Options:
    - “I> . Pickup” — Pickup of the »I>« phase overcurrent.
    - “I>> . Pickup” — Pickup of the »I>>« phase overcurrent.
    - “I>>> . Pickup” — Pickup of the »I>>>« phase overcurrent.
    - “Ipeak> . Pickup” — Pickup of the »Ipeak>« peak overcurrent.
    - “Prot . Pickup” — General Pickup (issued by the »Prot« module).

Note that depending on your other settings, the selected protection pickup can be (temporarily) blocked by the [Inrush Blocking](#) function. In this case, the »SOTF« does not get triggered, and the protection concept should take care of this.
4. ▷ Specify the **activity duration** (in seconds). »SOTF« is active for this period of time after the circuit breaker has been closed manually after a restart in CT-powered operation:
  - [Protection Para / SOTF] »SOTF . t-enable«.
5. ▷ Specify the **tripping delay** (in seconds). (A typical setting for this is “0 seconds”, i. e. instantaneous tripping.)
  - [Protection Para / SOTF] »SOTF . t«.

### 5.11 CLPU - Cold Load Pickup (WIC1-4 only\*)

\* This protection function is only usable with an external power supply. Therefore it is available only for WIC1-4 devices.

After a long outage, some types of objects to be protected – e. g. motors – have a higher current magnitude during re-energization, than would be the case after a short outage. If this cold load current exceeds an overcurrent protection threshold this can result in a false protection trip.

The Cold Load Pickup function can be used to stabilize the overcurrent stages (i. e. prevent an unwanted pickup / trip) during a re-energization after a long outage. This is available (individually) for each phase overcurrent and ground (earth) overcurrent stage.

Via setting parameter »50/51 Stab.«, the user can select one out of two different stabilization methods:

- “Factor” - The pickup threshold is (temporarily) increased during re-energization.
- 
- “Block.” - The overcurrent stage is (temporarily) blocked during re-energization.

The duration »tStab« of this stabilization phase and the duration »tOff« of what defines a “long” outage are settable.

**NOTICE!**

This module requires an external power supply, and therefore cannot be used with a self-supplied WIC1.

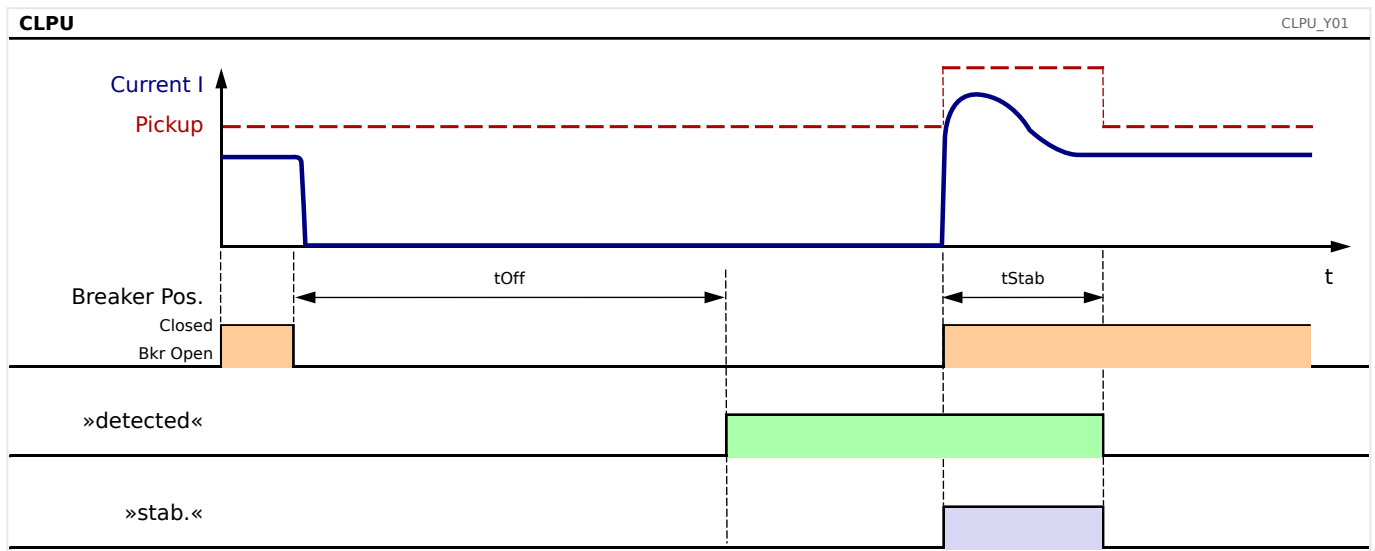

Fig. 66: Signaling example for the stabilization method “Factor”.

If the breaker position is detected as “open” the timer stage »tOff« is started. If the outage persists longer than »tOff«, the CLPU function is enabled so that temporary stabilization is started with the next re-energization (breaker position detected as “closed”). Then stabilization is carried out for the duration of »tStab«. Of course, »tStab« should be set

according to the expected duration of the cold load current. The detection of the breaker position is described at [↳ “Criteria for Determining the Switchgear Position”](#).

### 5.11.1 Functionality

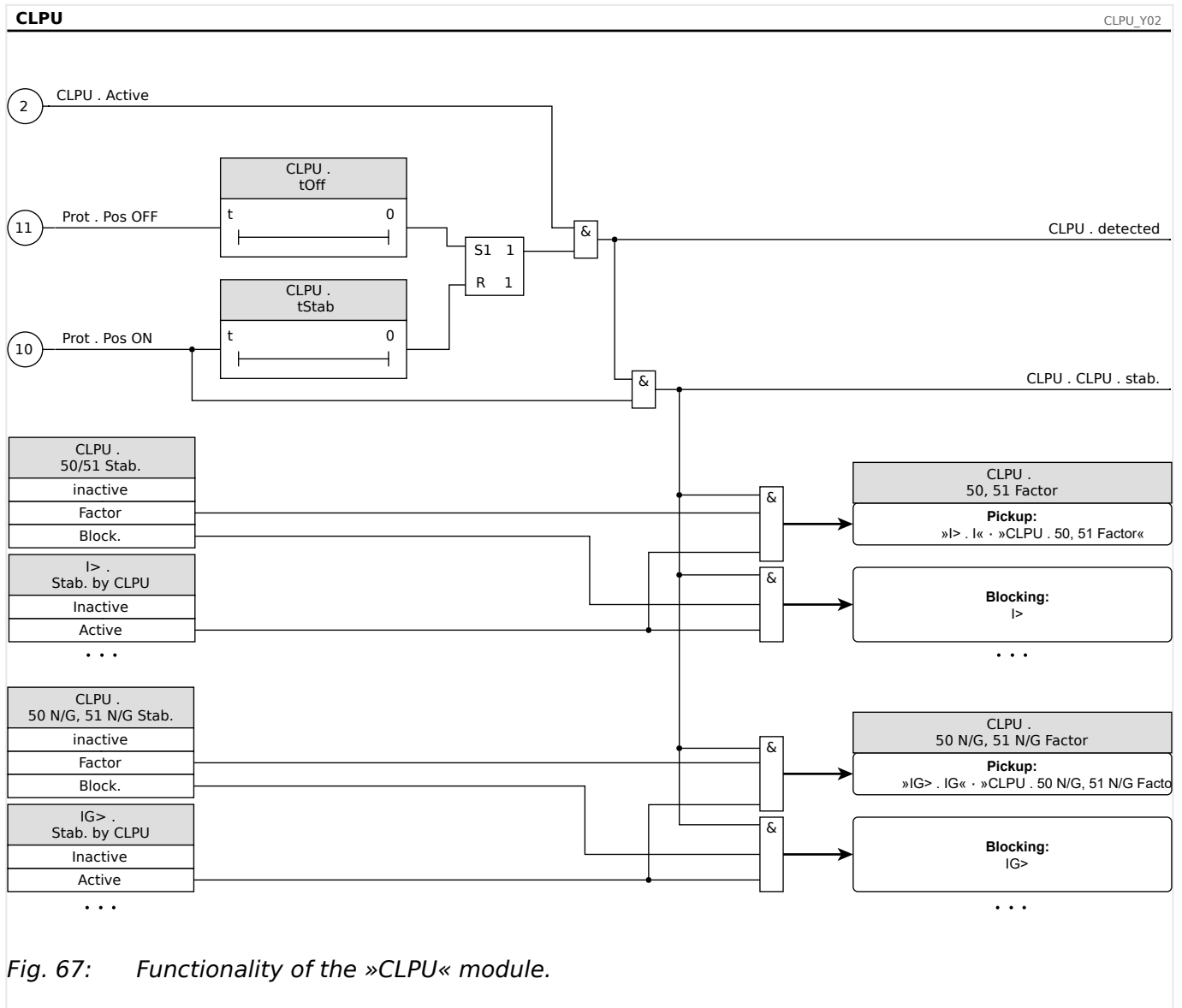

Fig. 67: Functionality of the »CLPU« module.

### 5.11.2 CLPU - Settings via DiggIMEC or via Smart view

⚙️

1. ▷ Activate the »CLPU« **module**.
2. ▷ Specify the **operating mode** with respect to the phase and ground (earth) overcurrent stages:

- [Protection Para / CLPU] »CLPU . 50/51 Stab.«
  - [Protection Para / CLPU] »CLPU . 50 N/G, 51 N/G Stab.«
- Options:
- “Factor” — The pickup threshold will be temporarily increased.
  - “Block.” — The overcurrent stage will be blocked.

3. ▷ If the operating mode has been set to “Factor” then define the **factor** by which the threshold will be multiplied.
  - [Protection Para / CLPU] »CLPU . 50, 51 Factor«
  - [Protection Para / CLPU] »CLPU . 50 N/G, 51 N/G Factor«
4. ▷ Specify the **outage time** that characterizes a “long” outage.
  - [Protection Para / CLPU] »CLPU . tOff«
5. ▷ Specify the **stabilization time** by setting it to the expected duration of the cold load current.
  - [Protection Para / CLPU] »CLPU . tStab«
6. ▷ Within each (phase or ground) overcurrent stage that you want stabilized, enable the CLPU stabilization.
  - [Protection Para / I>] »I> . Stab. by CLPU« = “Active”
  - ...

## 5.12 ExP – External Protection

The external protection module »ExP« can be used to trip the circuit breaker and record the event or alarm in case of any external event (e. g. sudden pressure, oil level, inter-tripping).

An external signal, that has been assigned to a Digital Input, is monitored, and (with some WIC1 variants) there is the option to make this dependent on another “condition” signal. The »ExP« module picks up if this external signal (or these two signals) become(s) active.

The availability and number of Digital Inputs, however, depends on the WIC1 variant. For the sake of simplicity, there is the following general concept for all WIC1 variants:

- There is always one protection stage, »ExP[1]«, active, and the »ExP[1]« trigger is pre-defined and set to DI2.

(Trivial exception: Device variants WIC1-xxxxxN without any Digital Input, where there is (obviously) no »ExP« available.)

- For WIC1 variants with configurable Digital Inputs, this setting is a default that can be changed.
- For WIC1 variants with 2 Digital Inputs, there is also a second protection stage »ExP[2]«, but it is deactivated by default. (Use DiggiMEC or Smart view to activate it if it is required.)

For »ExP[2]« (if available), the user can select between two operating modes:

- Unconditional — The »ExP[2]« module trips if this external signal is triggered.
- Conditional — The »ExP[2]« module trips if this external signal is triggered and - at the same time - a “condition” signal, that has been assigned to the parameter »Condition«, is active.

For »ExP[1]«, the operating Mode is always unconditional.



## 5.12.1 Functionality

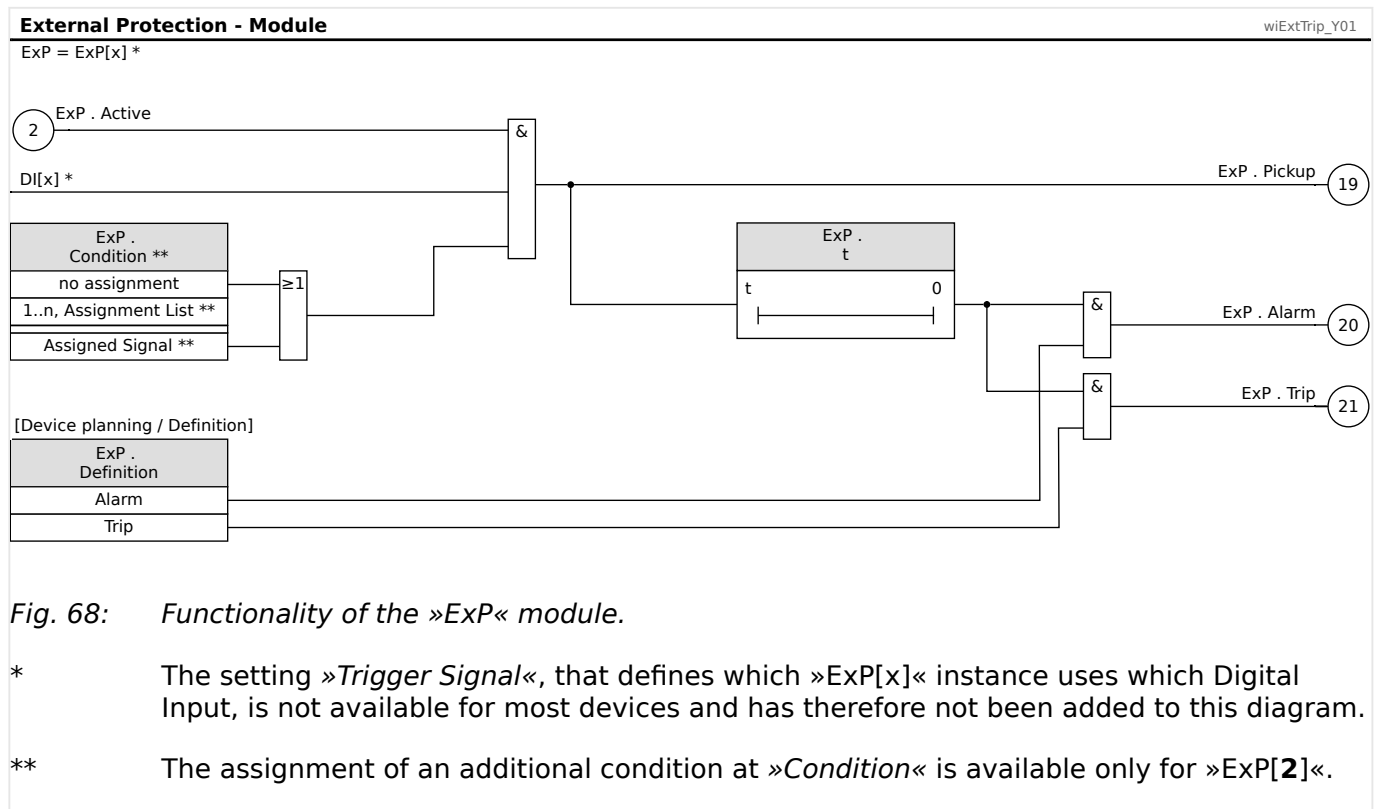

## 5.12.2 External Protection - Settings via DiggiMEC or via Smart view



1. ▷ Activate the protection stage and select whether it shall operate as a supervision or a protection function, see [↳ "5.1 »Prot« - General Protection Module"](#).
2. ▷ For device variants with configurable digital inputs, select the **trigger signal**, i. e. the external signal.
  - [Protection Para / ExP[1]] »*Trigger Signal*«  
Even if there is any choice available, you might usually want to keep the default "Prot . DI x".
3. ▷ Select the **condition** (only for »ExP[2]«), that needs to be fulfilled in addition to the external signal:
  - [Protection Para / ExP[1]] »*Condition*« =  
Options:
    - "-" — no condition, i. e. the »ExP[x]« module picks up as soon as the external signal gets active.
    - Or you select a particular signal, that you require to be active in addition to the external signal.
4. ▷ Specify the **tripping delay** (in seconds):
  - [Protection Para / ExP[1]] »*ExP[1] . t*«
5. ▷ And of course, on the hardware side, the respective Digital Input must be wired as required.

## 5.13 CBF - Circuit Breaker Failure [50BF, 62BF]

### 5.13.1 Principle - General Use

The »CBF« module is used to provide backup protection in the event that a breaker fails to operate properly during fault clearing. This signal is to be used to trip the upstream breaker (e.g. infeed of a busbar) either via an output relay or via Communication (SCADA).

The WIC1 detects a breaker failure based on the measured phase currents (ANSI/IEEE C37.2 50BF) and/or on the position indicators of the breaker (ANSI/IEEE C37.2 62BF - if supported by the WIC1 variant).

- A supervision timer is started as soon as the »CBF« module is triggered by a trip signal. A Breaker Failure is detected and an alarm signal »CBF . Alarm« is issued if the breaker is not determined as "open" within the set time.
- The criteria that are used for determining the breaker state are described in ["Criteria for Determining the Switchgear Position"](#).

#### Trigger

- Prot . TripCmd — The Trip Command triggers the »CBF« module. (See ["5.1 »Prot« - General Protection Module"](#) and, in particular, the signal (52) in [Fig. 44.](#))

#### Start/Trigger of the CBF Timer

The setting [Protection Para / CBF] »CBF . t-CBF« defines a supervision time: The timer is started once the CBF module is triggered. Even if the trigger signal drops again, this timer continues. If the timer elapses (before it gets stopped by the breaker having successfully opened), the »CBF« module issues an alarm. This alarm signal is to be used to trip the upstream breaker (backup).

#### NOTICE!



In order to prevent a faulty alarm of the »CBF« Module, the supervision time »CBF . t-CBF« must be greater than the sum of:

- Operating time of the WIC1
- + The close-open time of the breaker (please refer to the technical data of the manufacturer of the breaker)
- + Drop off time (current- or position indicators)
- + Security margin.

### 5.13.2 States / Standby

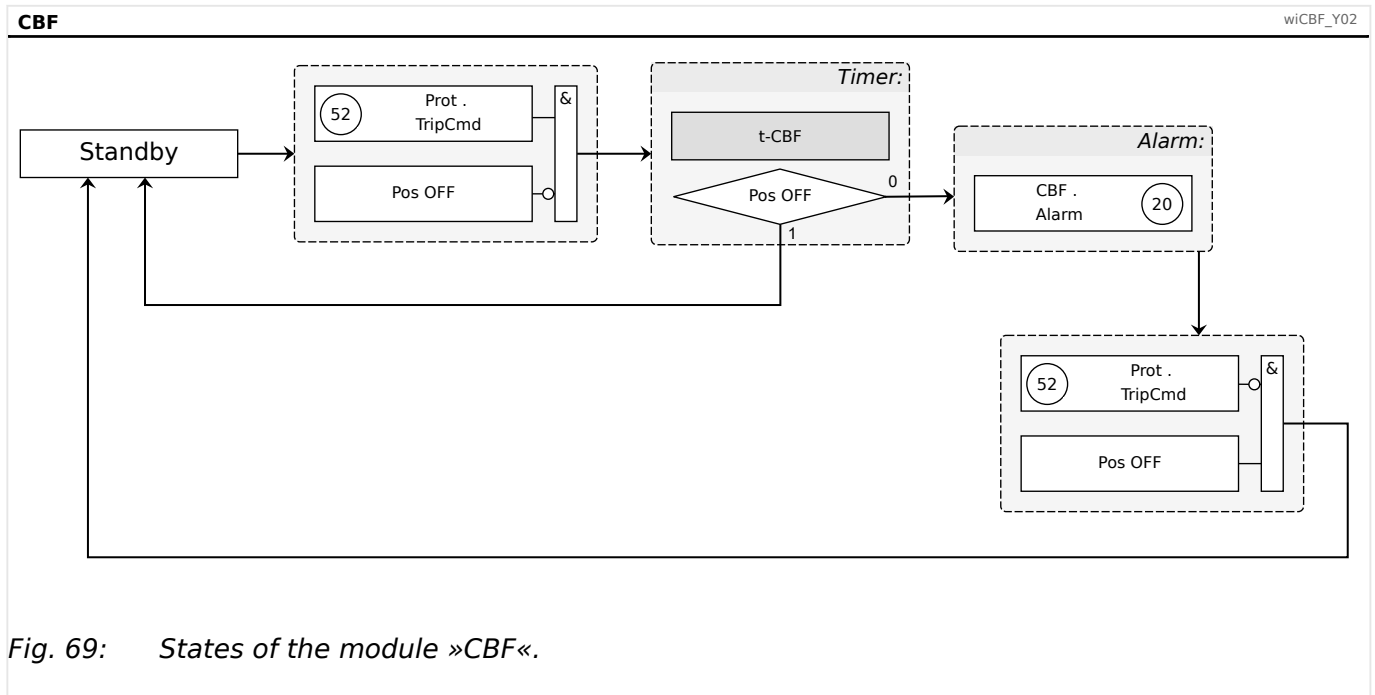

Fig. 69: States of the module »CBF«.

The »t-CBF« timer is stopped if the opening of the breaker is detected before the timer has elapsed.

After the timer has elapsed, however, the »CBF« module has already entered the “Alarm” state. This state is only left if the trigger signal, i. e. the Trip Command signal, drops off **and** the opening of the breaker is detected. (See also the state diagram [↩ Fig. 69.](#))

### 5.13.3 Functionality

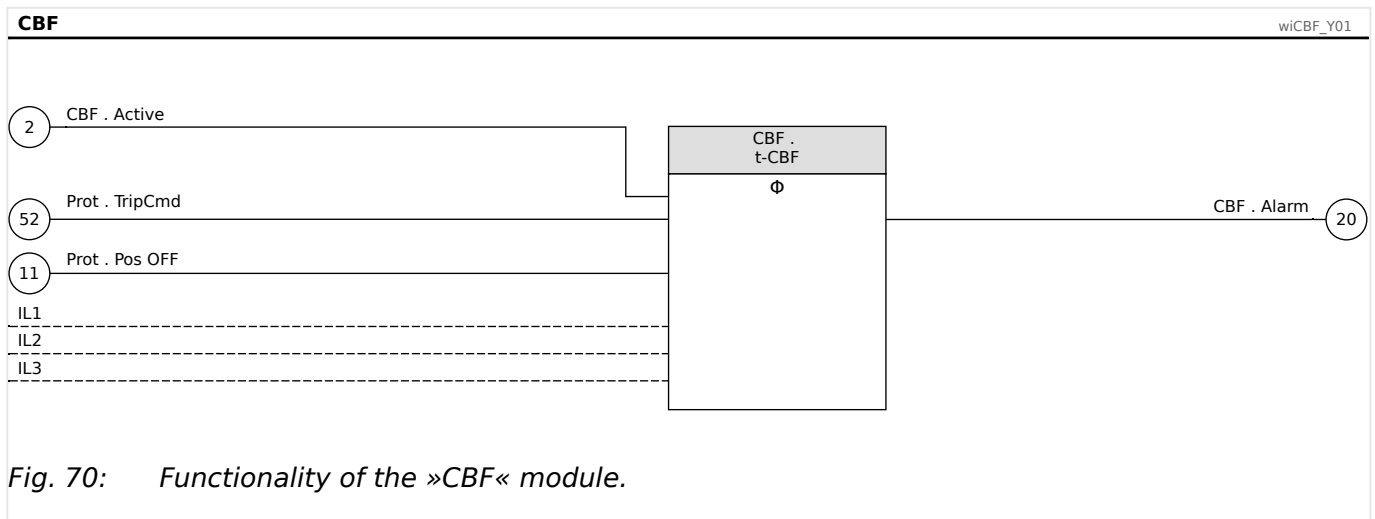

Fig. 70: Functionality of the »CBF« module.

## 5.14 Integrated Backup Phase Overcurrent Protection

The WIC1 has an additional integrated backup phase overcurrent protection (short: backup protection). It is activated automatically if the WIC1 detects a device-internal (hardware or software) error that still persists after several automatic restarts. This is **not** a typical protection function, that can be activated or deactivated at any time, but it is a special hardware-based operating mode of the WIC1. It guarantees some minimum protection functionality in case of a permanent device-internal problem. In this operating mode, there is only the backup phase overcurrent protection active, all other functionality is switched off. The WIC1 indicates this by the “System Error” LED being continuously lit up. (See also [5.14.1 Activation of the Backup Protection](#), [The »System« LED\(s\) - “Ready”, “Error”](#).)

The backup protection operates independent of the firmware. Therefore no settings are available, nor any kind of fault signaling (e.g. via SCADA or LEDs or fault recorder).

- The device variants WIC1-xxxxxx**1** (see [2.6.1 Order Form of the Device](#)) output a trip pulse as soon as there is sufficient electrical energy for this ( $\approx 0.8 \cdot I_{n,\min}$ ).
- For device variants WIC1-xxxxxx**2**, the pickup threshold is approx.  $20 \cdot I_{n,\max}$ .

The trip pulse is given after a delay of approx. 40 ms.

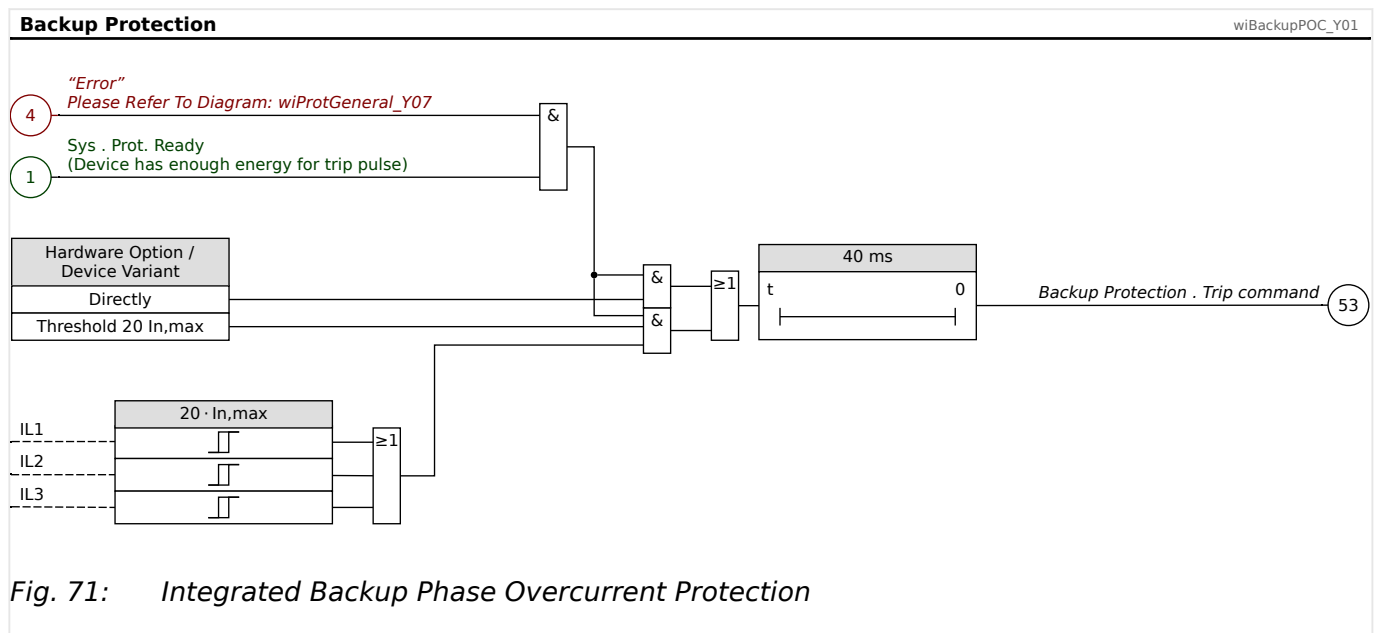

### 5.14.1 Activation of the Backup Protection

- If the WIC1 detects a device-internal (hardware or software) error it initiates a device restart. This is logged by the Self-Supervision.
- If within 10 minutes another internal error is detected the WIC1 initiates a device restart into a restricted “Protection-Only” mode. (See also  “The »System« LED(s) - “Ready”, “Error””.)

In this operating mode only protection and supervision functions are running. No communication, no SCADA, etc.

This mode is logged as a Self-Supervision warning. (The functionality to read the stored log entries has also been switched off. However, the entries can be read after the WIC1 has been restarted into normal operating mode.)

- If within another 10 minutes a third internal error is detected the WIC1 initiates a device restart into a “backup protection mode”: Only the backup protection is operating. (The software gets intentionally halted within the bootloader stage.)

This is indicated at the WIC1 by the middle / “System Error” LED shining constantly **red**. (See also  “The »System« LED(s) - “Ready”, “Error””.)

Since the software remains in the bootloader stage it is possible that the user starts a firmware upgrade. Chances are that such an upgrade solves the error.



The Direct Command »Sys . Force Backup Prot.« allows for (manually) entering the “backup protection” operating mode. This way one can test the backup protection, e. g. during commissioning.

This manually started backup protection gets stopped after approx. 10 seconds by an automatic restart. But of course, a manual cold restart also takes the WIC1 back to normal operation.

## 5.15 Supervision

### 5.15.1 BkrWear

Circuit breakers are often maintained based on a fixed time interval. These time intervals can be increased if more sophisticated operation data are available.

The »BkrWear« module monitors the number of trips and the interrupted currents. These data can be used to determine the breaker wear and to plan maintenance intervals.

#### **Counters**

- The magnitude of the interrupted currents is the maximum measured current in all phases from start of the trip pulse until clearance.

(Note, however, that current measurements have a limited measuring range: If a short circuit current exceeds this range it will not be registered with its full magnitude, and this will affect the current-based decisions of the »BkrWear« module.)

The value for the sum of interrupted currents can be accessed at [Operation / Condition Monitoring / BkrWear] »*BkrWear . Sum Itrip*«.

- The number of trip operations is counted.

The counter value can be accessed at [Operation / Condition Monitoring / BkrWear] »*BkrWear . Sum Trips*«.

**Wear Level Characteristic**

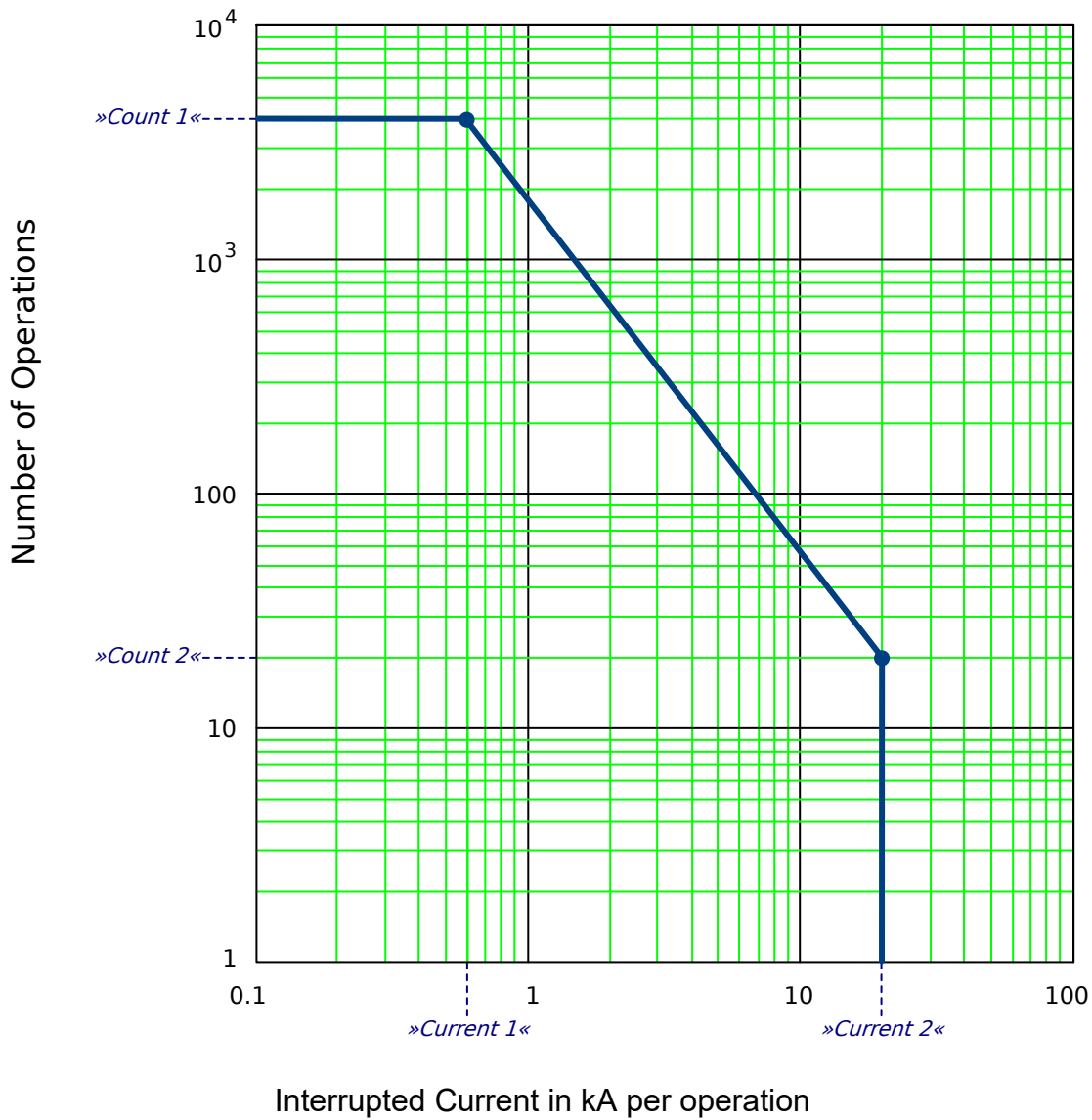

wiCBM\_Z67

Fig. 72: Wear curve, as it can be defined within the »BkrWear« module.

The wear level of the breaker is calculated based on the number of trips and the sum of interrupted currents. The calculated wear level helps to determine necessary maintenance of the breaker.

The »BkrWear« module supports the definition of two points on the curve. For currents between these thresholds there is a logarithmic interpolation to calculate the wear progress.

The two points on the curve are a characteristic property of the connected circuit breaker and are therefore usually supplied by the manufacturer. The setting parameters at the WIC1 are as follows:

- Point 1 is the rated current of the circuit breaker and the maximum allowed number of switching operations at the rated current.
  - [Protection Para / Condition Monitoring / BkrWear] »BkrWear . Ir«



- [Protection Para / Condition Monitoring / BkrWear] »BkrWear . N(Ir)«
- Point 2 is the max. short-circuit current and the maximum allowed number of switching operations at this max. short-circuit current.
  - [Protection Para / Condition Monitoring / BkrWear] »BkrWear . Isc«
  - [Protection Para / Condition Monitoring / BkrWear] »BkrWear . N(Isc)«

**CAUTION!**

The curve is only correctly defined if the following conditions are fulfilled:

- »BkrWear . Isc« > »BkrWear . Ir«
- »BkrWear . N(Isc)« > »BkrWear . N(Ir)«

Otherwise the wear level feature will remain inactive.

- The value for the wear level is a percentage and can be accessed at [Operation / Condition Monitoring / BkrWear] »BkrWear . Bkr Wear Level«.

If it reaches 100 % the circuit breaker urgently needs maintenance.

**5.15.1.1 BkrWear - Settings via DiggiMEC or via Smart view**

1. ▷ Specify whether the »BkrWear« module shall monitor only the counter values, or the counters together with the calculated wear level:
  - [Device planning / Projected Elements] »BkrWear . Mode« =  
Options:
    - “Counters only” — only the counter values are monitored.
    - “Counters, Wear Lev.” — counter values and wear level are monitored.
2. ▷ Set the maximum counter value for the number of trips:
  - [Protection Para / Condition Monitoring / BkrWear] »BkrWear . Alarm Thresh. Sum Trips«
3. ▷ Set the maximum value for the sum of interrupted currents:
  - [Protection Para / Condition Monitoring / BkrWear] »BkrWear . Alarm Thresh. Sum Itrip«
4. ▷ If the wear level shall be used set the maximum value for it:
  - [Protection Para / Condition Monitoring / BkrWear] »BkrWear . Max. CB Wear Level« - as a percentage value from 50% to 100%.
5. ▷ Make sure that the rated primary current is correctly set at [Field Para / CT] »CT pri«, see [5.2.1 Field Parameter Settings via DiggiMEC or via Smart view](#). Only then can the »BkrWear« module be set active:

- [Protection Para / Condition Monitoring / BkrWear] »*BkrWear . Function*« = "Active"

If the maximum number of trips is exceeded the signal »*BkrWear . Alm(mx.Sum.Tr)*« is issued.

If the maximum for the interrupted currents is exceeded the signal »*BkrWear . Alm(mx.Sum.Itrip)*« is issued.

If the threshold for the wear level is exceeded the signal »*BkrWear . Alm (CB Wear Lev.)*« is issued.

If any of the maximum values is exceeded the alarm message »*BkrWear . Alarm*« is issued, and it is recommended to maintain the breaker.

Following the maintenance, all values (counters and wear level) can be reset using the Direct Command [Operation / Reset] »*BkrWear . Reset*«.

### 5.15.1.2 Functionality

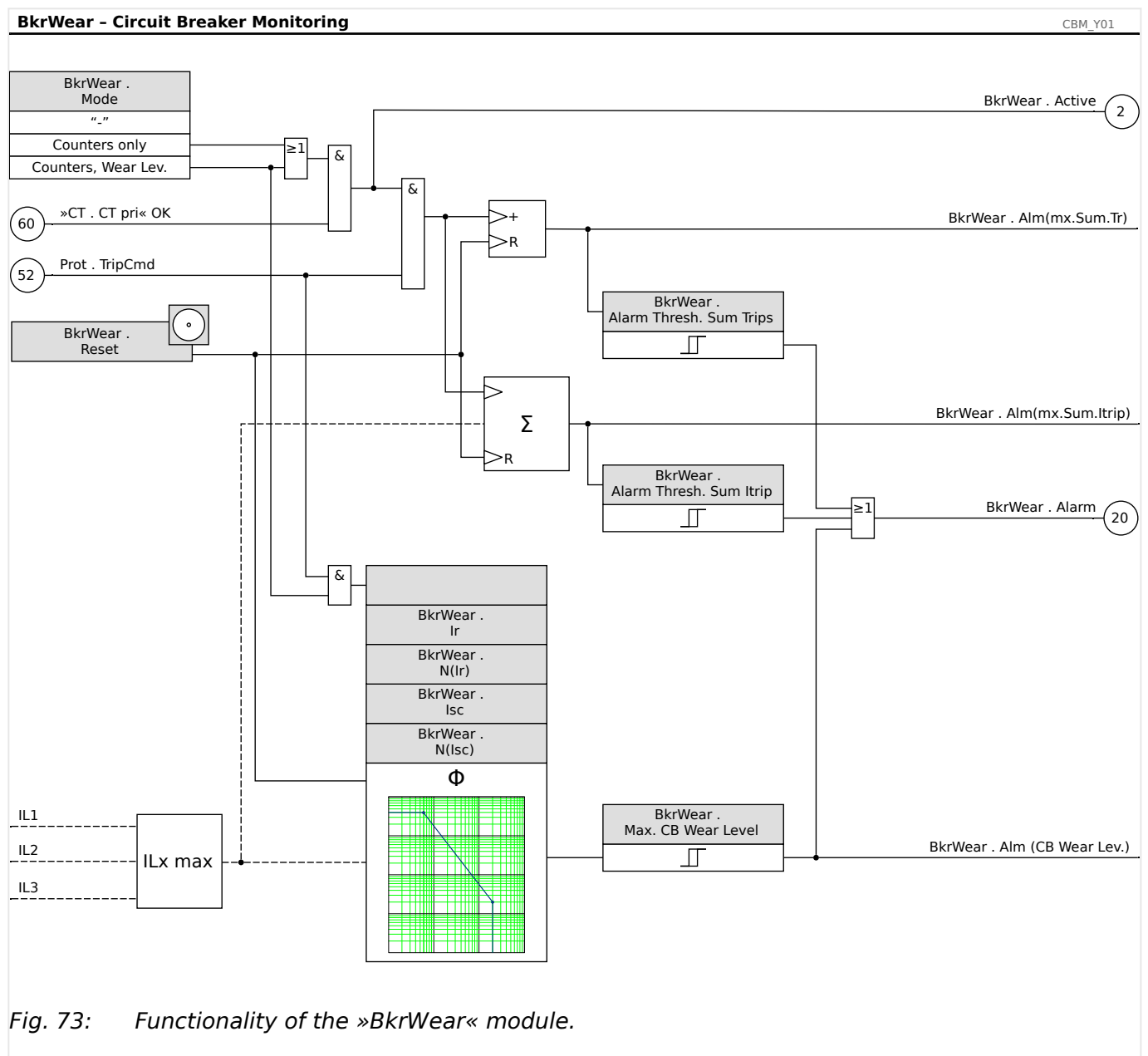

Fig. 73: Functionality of the »BkrWear« module.

### 5.15.2 »TCM« – Trip Circuit Monitoring [74TC]

The trip circuit monitoring is used for monitoring if the trip circuit is ready for operations.

The WIC1 module »TCM« monitors the trip circuit based on internal measurements if it is permanently supplied with sufficient energy (↳ “2.3 Supply of a WIC1”). If an interrupt is detected an alarm signal is issued after the (internally fixed) delay of 10 seconds.

If a trip circuit is used that must not be operated continuously it is necessary to block the module »TCM« in case of an open breaker (via assigning an appropriate input signal to [Protection Para / TCM] »TCM . ExBlo«). Such a blocking signal can be a digital input or the detected breaker position (see ↳ “5.1.4.1 Switchgear Configuration”).

### 5.15.3 Condition Monitoring – Life Load

The WIC1 evaluates the operating time in dependency on the phase current flow. This allows for checking whether the WIC1 – and therefore the protected object as well – have been frequently under high load.

The WIC1 divides the current measuring range into (fixed) intervals. For each interval, the operating time is measured as long as the maximum RMS value of the three phase currents is within this interval. These data are permanently kept updated, beginning with the first WIC1 start. Only in case of a [factory reset](#) or a firmware update will the statistics be reset.

The data collection even continues if the »Life Load . Mode« parameter is set to inactive in the [Device planning / Projected Elements], only the evaluation and display of this statistic then stops.

There are two menu items to access the resulting statistic:

- [Operation / Condition Monitoring / Life Load (Values)] – Numerical values are shown in tabular form.
- [Operation / Condition Monitoring / Life Load] – The values are shown as a graphical histogram.

(The data are always displayed using “days” as unit, but of course, the internal evaluation is carried out with better precision.)

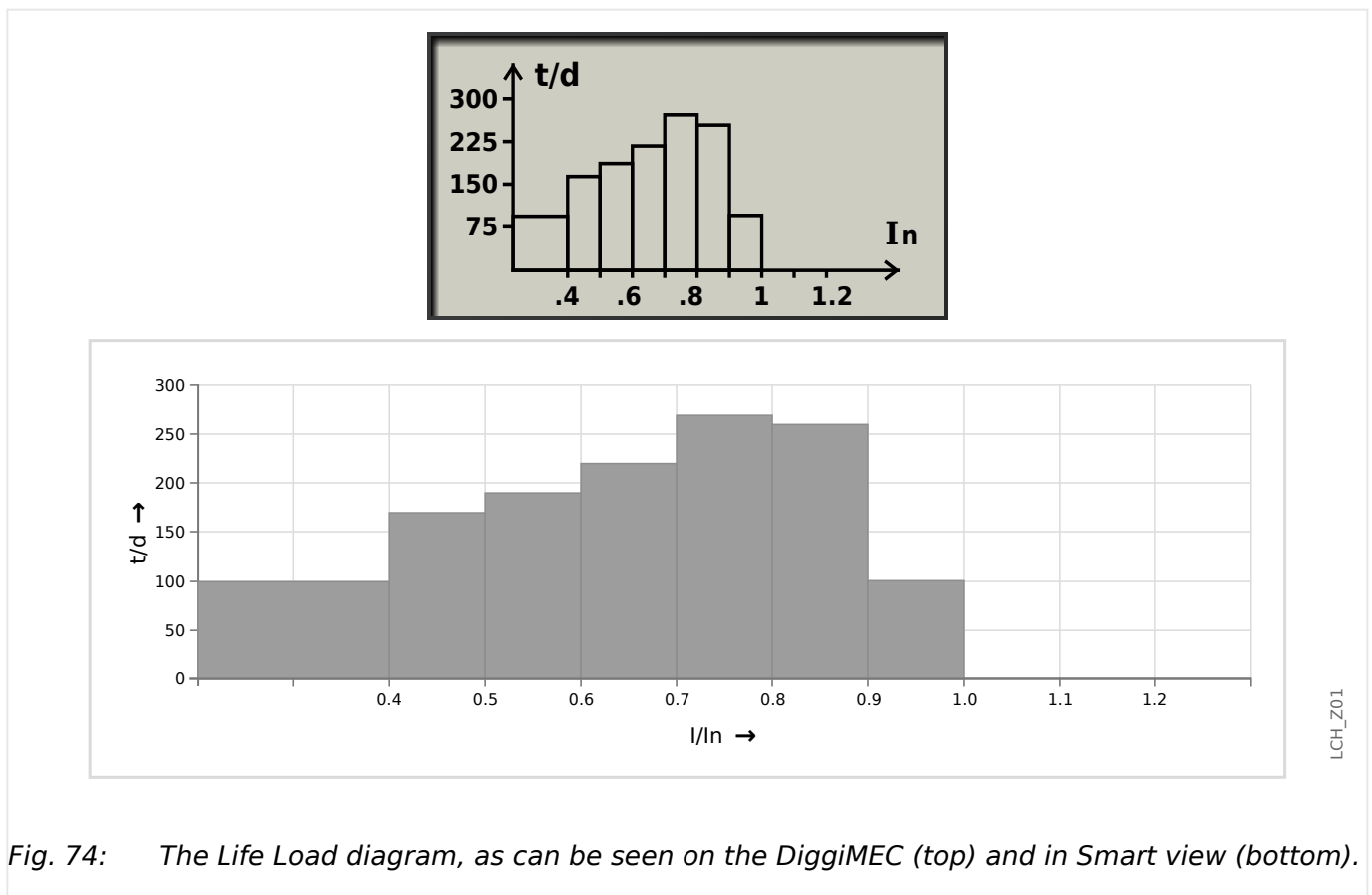

Fig. 74: The Life Load diagram, as can be seen on the DiggiMEC (top) and in Smart view (bottom).

Note that for a self-supplied WIC1, the first interval “< 0.4 In” is influenced by the fact that the WIC1 cannot measure any operating times if the phase current is too low. (An externally supplied WIC1-4, however, evaluates also small phase currents, provided that the breaker position is determined as “closed” – according to the criteria described in [“Criteria for Determining the Switchgear Position”](#).)

### Alarm Signal

The »Life Load« module can (optionally) issue an alarm signal if the WIC1 has been running with too high load for a particular time.

The following settings are available for this:

- [Protection Para / Condition Monitoring / Life Load] »/« - This is the current threshold, above which the alarm might be issued (depending on the set time threshold).
- [Protection Para / Condition Monitoring / Life Load] »Threshold t« - This is the time threshold.

All operating times for the intervals above the current threshold are summed up, and if this sum is above the setting for the time threshold then the alarm signal »Life Load . Alarm« is issued.

- [Operation / Condition Monitoring / Life Load (Values)] »Time to Alarm« - This is the time left until the alarm signal is issued. This value counts backwards from its initial value »Threshold t« to 0.
- [Operation / Reset] »Life Load . Rst. Alarm« - Direct command to reset the alarm signal. The value of »Time to Alarm« also gets reset to its initial value »Threshold t«.

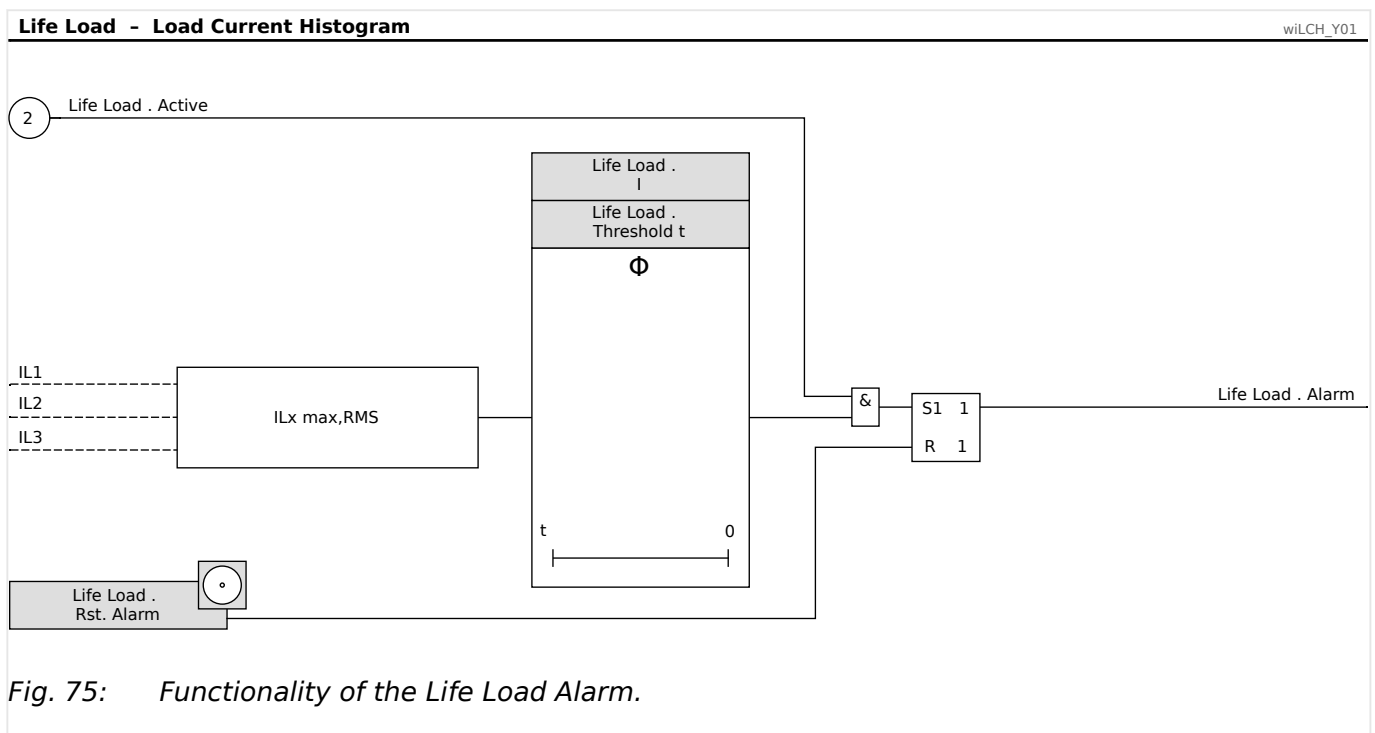

Fig. 75: Functionality of the Life Load Alarm.

### 5.15.4 Condition Monitoring – Peak Current Pointer

The »Peak Current Ptr« mimics an analog pointer instrument by calculating a time-average of the maximum phase current. This allows for checking whether the WIC1 – and therefore the protected object as well – have been under high load.

The resulting values can be checked at these menu items:

- [Operation / Condition Monitoring / Peak Current Ptr (Values)] – Numerical values are shown in tabular form.
- [Operation / Condition Monitoring / Peak Current Ptr] – The values are shown as a diagram. The diagram design is inspired by an analog pointer instrument.

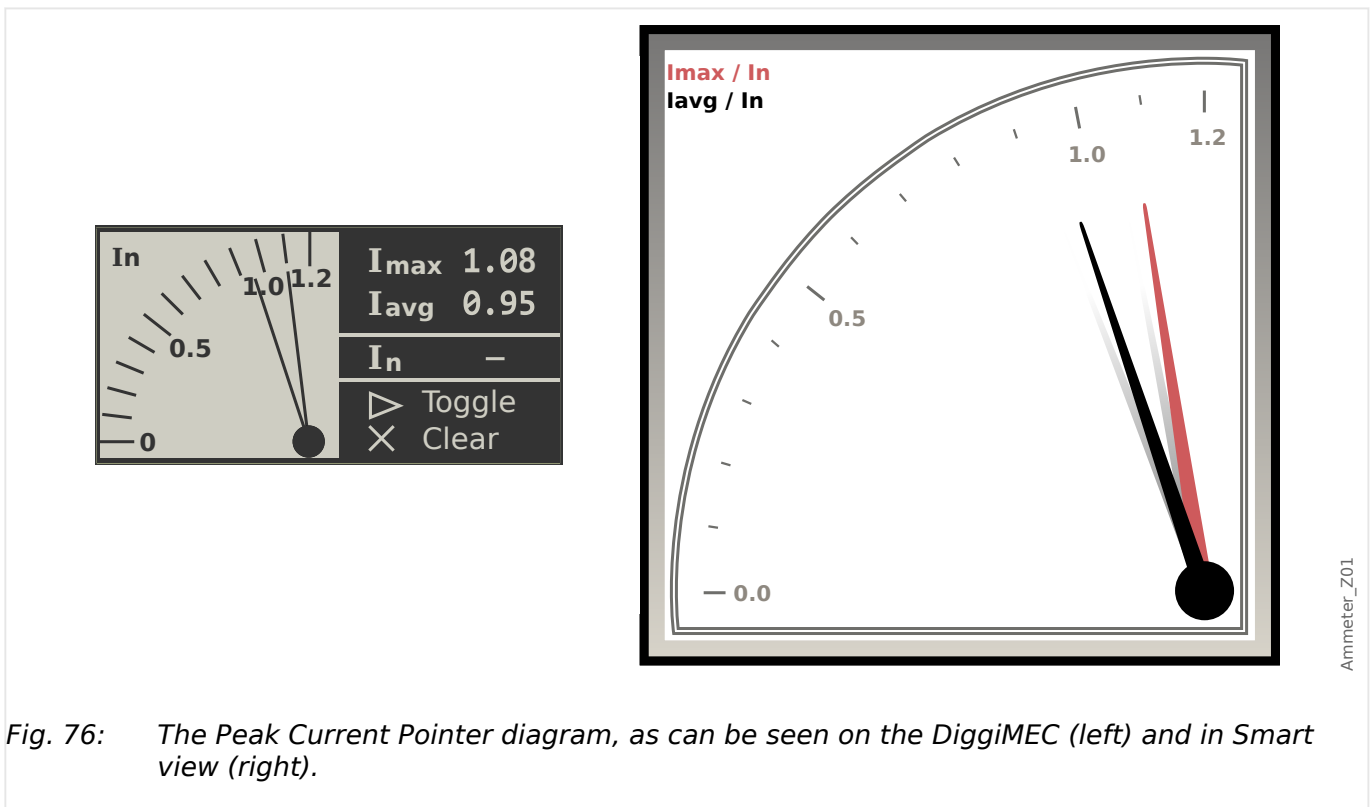

Fig. 76: The Peak Current Pointer diagram, as can be seen on the DiggiMEC (left) and in Smart view (right).

The following values are shown:

- » $I_{avg}$ « – the average of the three maximum RMS phase current values, averaged over the selected time window »*Time win. for calc. avg.*«.

Note that the average value is invalid for some time after a restart of the WIC1 and after a reset. Only after the selected time window has elapsed will the average » $I_{avg}$ « become valid.

- » $I_{max}$ « – the maximum value of the average » $I_{avg}$ « since the last manual reset.

The time window for calculating the average value » $I_{avg}$ « is set here:

- [Protection Para / Condition Monitoring / Peak Current Ptr] »*Time win. for calc. avg.*«

A manual reset of the » $I_{max}$ « maximum value can be carried out either at the DiggiMEC by pressing the » $\times$ « key, or via this Direct Command:

## 5 Protective Elements

### 5.15.4 Condition Monitoring - Peak Current Pointer

- [Operation / Reset] »Clear«



# 6 Fault Recorder

## Purpose of the Fault Recorder

The *Fault Recorder* provides compressed information about faults (e.g. Trip Causes).

If a DiggiMEC is connected when the fault happens, a pop-up window is sent onto the display in order to draw the user's attention to the fault. (See [“6.1 Fault Display screen \(Overlay / Pop-up\) on the DiggiMEC”](#).) This might be helpful for fast fault analysis.

After connecting a PC, a detailed fault analysis can be done by means of Smart view.

## Times and Durations

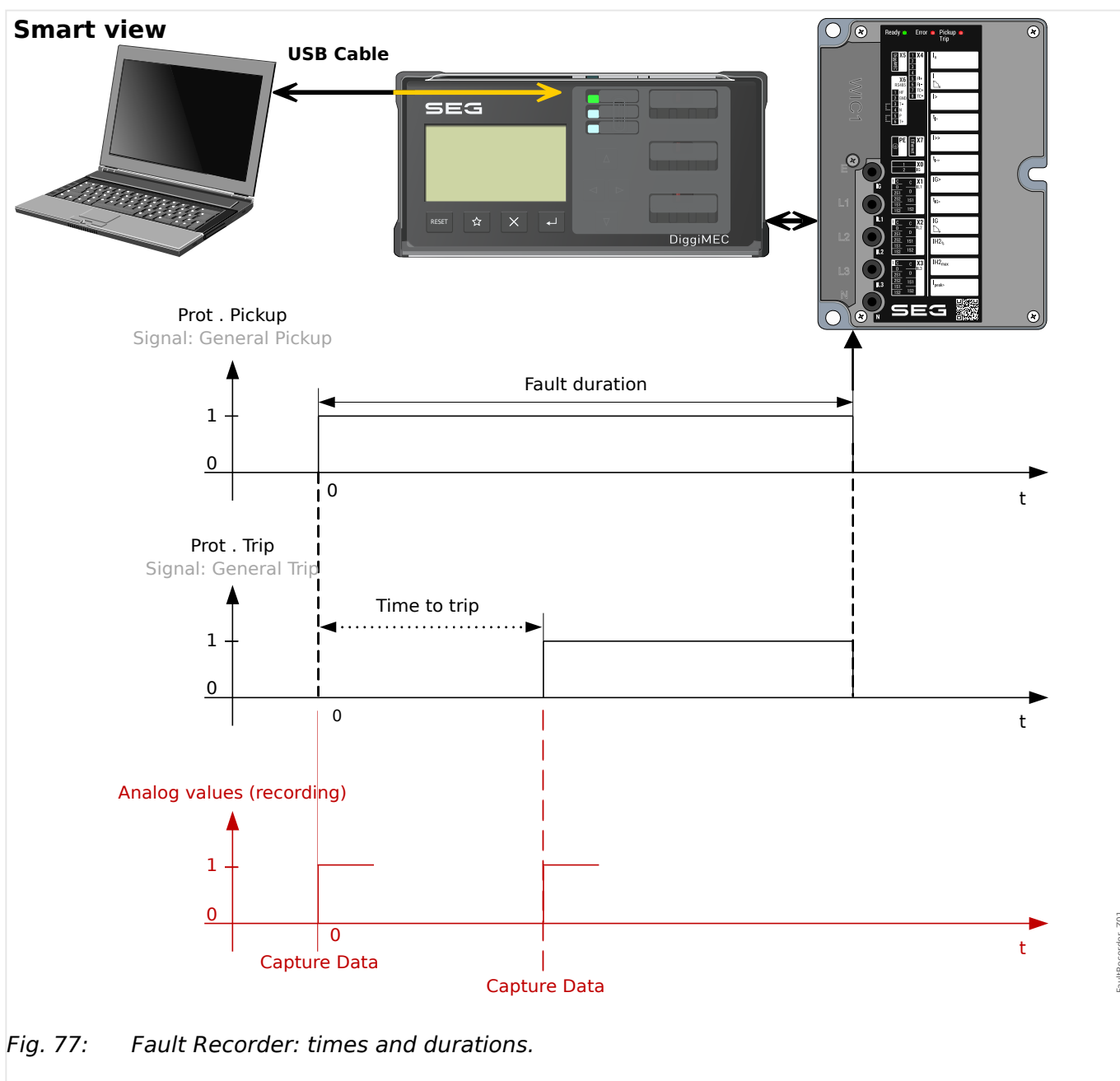

Fig. 77: Fault Recorder: times and durations.

### **Behaviour of the Fault Recorder**

The *Fault Recorder* is triggered by the rising edge of the »Prot . Pickup« (General Pickup) signal. (Note that »Prot . Pickup« (General Pickup) is an OR-connection of all pickup signals, see [↳ “5.1 »Prot« - General Protection Module”](#).) (Since the General Pickup signal triggers the Fault Recorder one can say that the first protection pickup triggers the Fault Recorder.) The *Fault Recorder* is **not** triggered by functions that have been configured as »Definition« = “Alarm” (see [↳ “Definition \(“Alarm ↔ Trip”\) of a Protection Function”](#)).

If the (General) Pickup is followed by a (general) Trip (signal »Prot . Trip«) then the Fault Recorder updates all data. In this case all values describe the fault situation at the moment of the trip.

## 6.1 Fault Display screen (Overlay / Pop-up) on the DiggIMEC

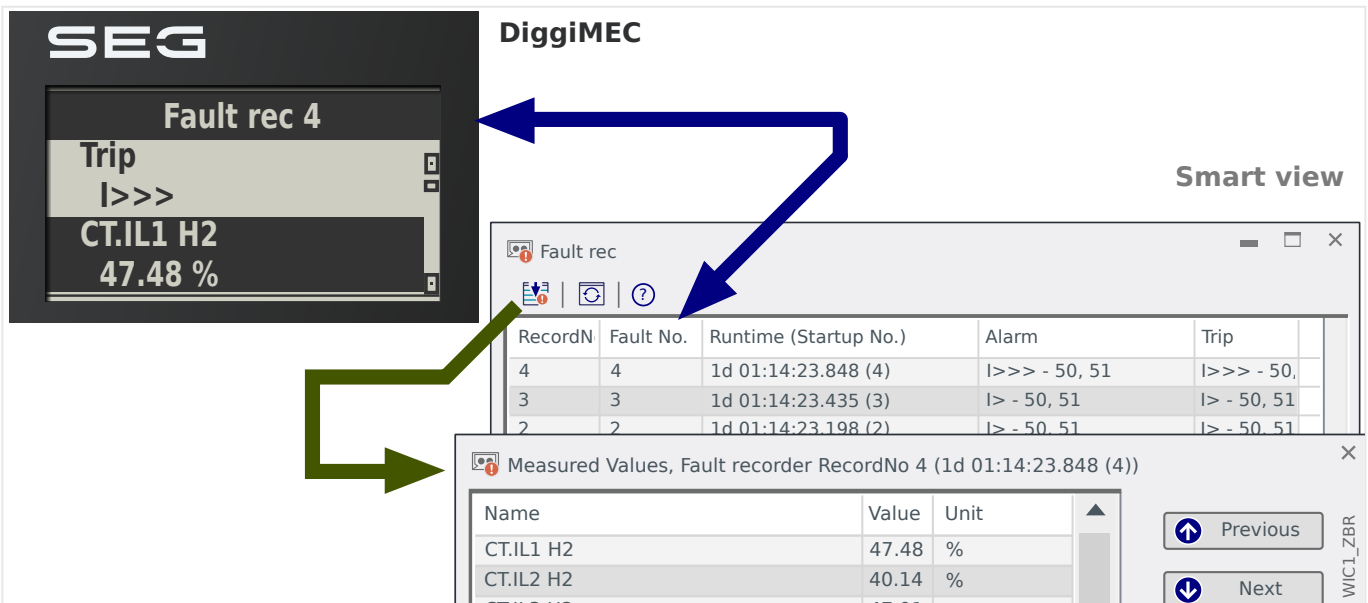

Fig. 78: Fault Display screen on the DiggIMEC HMI and Fault Recorder dialog(s) in Smart view.

A Fault Display screen appears on the DiggIMEC display when the General Pickup («Prot . Pickup») drops off.

### NOTICE!



No time to trip will be shown if the pickup signal that triggers the fault recorder is issued by another protection module than the trip signal. This might happen if more than one protection module is involved into a fault.

### CAUTION!



There is no real-time clock available with the WIC1. Therefore each Fault Record is labeled with a relative time. This relative system time specifies the uptime of the WIC1, that is the duration since the last (warm or cold) restart.

In addition, Smart view also shows the total number of WIC1 restarts (in parentheses).

### NOTICE!



Please note: The parameter settings (thresholds, etc.) that are shown in a fault record are not part of the fault record itself. They are always read out from the current device setting. If it may be the case that the parameter settings shown in a fault record were updated, they are indicated with an asterisk symbol within the fault record.

To prevent this please proceed as follows:

Save any fault record that should be archived to your local network/hard disk before doing any parameter change. Delete all the fault records in your fault recorder afterwards.

## 6 Fault Recorder

### 6.1 Fault Display screen (Overlay / Pop-up) on the DiggIMEC

The fault records are saved (in a power-fail-safe manner) within the *Fault Recorder*. If there is no more memory free, the oldest record will be overwritten (FIFO). Up to 10 records can be stored.

It is always the last (newest) fault that pops up on the DiggIMEC display. By pressing the »←« key (“OK”) the overlay/pop-up is closed, but will re-appear with the next restart. Press the »Reset« key or use the Direct Control »Rst. LEDs, Fls« to close it permanently.

## 6.2 Content of a Fault Record

A fault record comprises information about:

<b>Part 1: Common Information (independent of protection function)</b>	
Runtime (Startup No.)	Timestamp of the Fault. This specifies the uptime of the WIC1, and the total number of WIC1 restarts (in parentheses).  Example: 1d 01:14:23.848 (4) — The fault occurred at 1 day, 1 hour, 14 minutes, 23.848 seconds after the 4 <sup>th</sup> restart. (Restarts counted from WIC1 delivery.)
Fault No.	This counter will be incremented with each fault (i. e. with every (General) Pickup »Prot . Pickup«).
Time to trip	The time between pickup and trip. Please note: No time to trip will be shown if the first pickup and the first trip are issued by different protection stages or modules.
Pickup	Name of the module / protection stage that picked up first.
Trip	Name of the module / protection stage that tripped first.

<b>Part 2: Information depending on the active settings</b>	
Measured Values	Various measuring values at the time of the pickup or trip are displayed.

### 6.3 How to Read Out the Fault Recorder

In order to read out a fault record there are two options available:

- Option 1: A Fault has popped up on the DiggiMEC display (because a trip or pickup has occurred).
- Option 2: Call up the Fault Recorder menu manually.

*Option 1 (in case a fault record pops up on the DiggiMEC display (overlay):*

- Analyze the fault record by using keys “▲” and “▼”.
- Or close the Pop-up by using the »←« key.

*Option 2:*

- Enter the menu branch [Operation / Recorders / Fault rec], using either the DiggiMEC panel or Smart view.
- Select a fault record.

#### **How to Navigate Within the Fault Recorder via DiggiMEC**

<b>Navigation within the Fault Recorder</b>	<b>Key</b>
Back to overview.	◀
Next (upper) item within this fault record.	▲
Next (lower) item within this fault record.	▼

## 7 Self-Supervision

The protection devices apply various check routines during normal operation and during the start-up phase to supervise themselves for faulty operation.

Self-Supervision within the devices		
Supervision of...	Supervised by...	Action on detected issue...
Supervision of data consistency after an outage of the power supply (e. g. outage of the power supply while changing the parameter settings).	An internal logic detects corrupt data after an outage of the power supply.	If the data is corrupt, all software-based protection modules are stopped, and the device continues with the <a href="#">backup protection</a> .
Parameter Setting (Device)	<i>Smart view</i> carries out plausibility checks to protect the parameter settings.  (For the settings via DIP or HEX switches there is no need for any plausibility checks.)	A problem within the parameter configuration can be detected by means of plausibility checks.  Detected implausibilities are highlighted by a question mark symbol on the DiggiMEC and within <i>Smart view</i> .
Quality of the power supply	A hardware circuit ensures that the device can only be used, if the CT-based power (or the external power supply, if available) is in the range specified by the technical data.	If the supply voltage is too low, the device does not start, or it stops operating.  If the voltage is sufficient for the WIC1, but not enough for loading the capacitors of the trip impulse output, then the green "Ready" LED (DiggiMEC: "System" LED) ceases to shine.
Internal data of the device (memory load, internal resources, ...)	An internal module monitors the system utilization.	The module for the supervision of the system utilization initiates in case of a fatal error a reboot of the device. Some fault types are indicated via the System/Error LED, see <a href="#">↪ "The »System« LED(s) - "Ready", "Error"™</a> .  (Please refer to <a href="#">↪ "11 Troubleshooting"</a> .)  The issue will be recorded as a system message.



An externally supplied WIC1-4 allows for connecting an external output relay that operates as a "Healthy" / self-supervision contact. See [↪ "3.8.1 Self-Supervision Contact for the WIC1-4"](#).

## 7.1 Device Start (Reboot)

The WIC1 starts (or reboots) in any of the following situations:

- It is connected to the supply voltage (or gets sufficient electrical energy from the CTs),
- the user initiates (intentionally) a restart of the device,
- the device is set back to factory defaults,
- the internal self-supervision of the device detects a fatal error.

Note that every WIC1 restart also triggers a DiggiMEC restart, if connected. If a PC with Smart view is connected, then the connection is lost. To reconnect, close the previous session in Smart view (menu item [File / Close]), then select [Device / Receive Data from Device].

Every restart of the WIC1 – except for a normal start-up – appears as a new entry within the Self-Supervision messages, [↪ “7.2 Self-Supervision Messages”](#).

The reason for a device start/reboot is shown numerically as “Value”. The value “1” in the example above means a normal start-up. Please see the table below for a full list.

Device Start-up Codes	
1.	<b>Normal Start-up</b> Start-up as a normal cold restart.
2.	<b>Reboot by the Operator</b> Device reboot triggered by the operator via HMI or <i>Smart view</i> .
3.	<b>Forced Reboot (initiated by the WIC1 processor)</b> The WIC1 processor identified invalid conditions or data.
4.	<b>Illegal Memory Access</b> Reboot after illegal memory access.
5.	<b>Exceeded Time Limit of the Protection Cycle</b> Unexpected interruption of the Protection Cycle.
6.	<b>Sags of Power Supply</b> Reboot after short-term sag or outage of the supply voltage / current via CTs.
12.	<b>Reset to Factory Defaults</b> Restart that is carried out due to reset to factory defaults. (See also <a href="#">↪ “2.13 Reset to Factory Defaults”</a> .)
13.	<b>Return from Backup Protection into normal operation</b> After a transition into the operating mode “Backup Protection”, the WIC1 returns to normal operation after approx. 10 seconds via an automatic restart. (See also <a href="#">↪ “5.14.1 Activation of the Backup Protection”</a> .)



## 7.2 Self-Supervision Messages

Enter [Operation / Self-Supervision / Messages] »Messages« to access the list of Self-Supervision messages. In particular, it is recommended to check these in case of some problem with respect to the WIC1 functionality.

The Self-Supervision collects various security-related messages (e. g. restarts or setting changes) and WIC1-internal status messages, warnings and error messages.

All Self-Supervision messages that can potentially appear are described here: [↗](#) “11 Troubleshooting”.

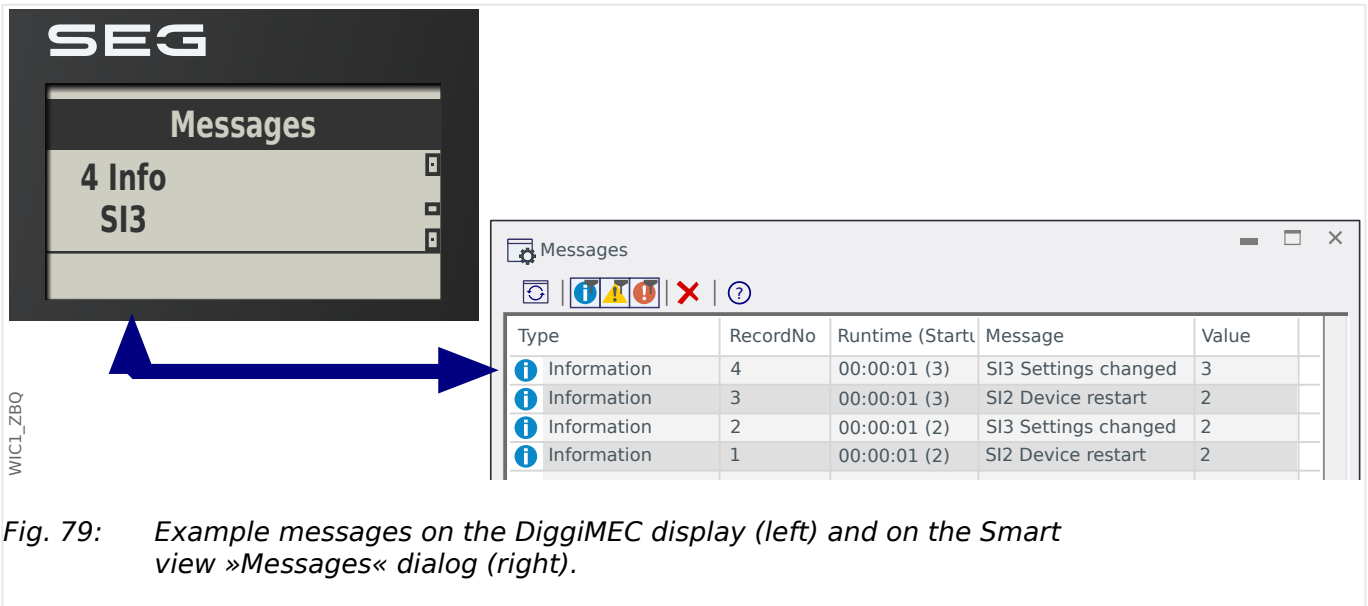

Fig. 79: Example messages on the DigiMEC display (left) and on the Smart view »Messages« dialog (right).

All messages are displayed together with an identifier (e. g. “**S12** Device restart” or “**S13** Settings changed”); this identifier makes it easier to locate detailed information about it. The identifier always starts with an “**S**”, next comes either an “**I**” (for “Information”), a “**W**” (for “Warning”), or an “**E**” (for “Error”).

General idea:

- **E** - Errors indicate serious problems. It is advisable to look up the message and take the recommended actions.
- **W** - Warnings should be checked by the user. They might indicate a problem that needs to be solved, so that - depending on the message and application - it might be advisable to check warnings.
- **I** - Information messages can be helpful for a thorough analysis of a problem, but in general, such messages have indeed only an informative character and do not affect the operation of the WIC1.

The example messages shown above ([↗](#) Fig. 79) are two pairs of device restarts (**S12**) plus setting changes (**S13**). Note that all timestamps (third column) are relative times since the last restart, because the WIC1 lacks a real-time clock. Whenever there is such a pair of **S12** and **S13**, occurring within only a second time, it is a warm restart following a settings change via DIP/HEX switches. (See also [↗](#) “Validity of the DIP-/HEX-Switches”.)

The Self-Supervision messages can be conveniently browsed through using *Smart view*.

All messages are listed in one dialog window. There are buttons  in the toolbar of this dialog that allow for restricting the list to particular severity types: It is possible to e. g. hide all “information” messages and show only the types “warning” and “error”.

There is also a delete button : It allows for removing the currently selected message plus all older ones.



Note that it is not possible to pick only one particular message for deletion. A deletion always removes all messages until (including) the currently selected one.

## 8 Commissioning

Before starting work on an opened switchboard it is imperative that the complete switchboard is dead and the following 5 safety regulations are always met:

### DANGER!



Safety precautions:

- Disconnect from the power supply (if available for the WIC1)
- Secure against reconnection
- Verify if the equipment is dead
- Connect to ground and short-circuit all phases
- Cover or safeguard all live adjacent parts

### DANGER!



The secondary circuit of a current transformer must never be opened during operation. The prevailing high voltages are dangerous to life.

### WARNING!



Even when the auxiliary voltage, or the protective device, is switched off, it is likely that there are still hazardous voltages at the component connections.

All locally applicable national and international installation and safety regulations for working at electrical power installations must always to be followed (e.g. VDE, EN, DIN, IEC).



It is strongly recommended to fasten a permanent label somewhere in the low-voltage cell (e. g. as a banneret fixed to the CT cables) with information about the CT type. After the site has been put into operation the medium-voltage parts must no longer be accessed, so that there is no way anymore to find out the CT type.

**WARNING!**



Prior to the initial voltage connection, the following must be guaranteed:

- Correct grounding of the device
- All signal circuits must be tested
- All control circuits must be tested
- The transformer wiring must be checked
- Correct rating of the CTs
- Correct burden of the CTs
- The operational conditions must be in line with the Technical Data
- Correct rating and function of the CT fuses;
- Correct wiring of all digital inputs
- Polarity and capacity of the supply voltage (if applicable for this WIC1 variant)

### 8.1 Commissioning / Protection Test

**WARNING!**



Putting into operation/Protection test must be carried out by authorized and qualified personnel. Before the device is put into operation the related documentation has to be read and understood.

**WARNING!**



With any test of the protection functions the following has to be checked:

- Are all signals/messages correctly generated?
- Do all general parameterized blocking functions work properly?
- Do all temporary parameterized (via DI) blocking functions work properly?
- To enable checks on all LEDs and relay functions, these have to be provided with the relevant alarm/pickup/tripping signals of the respective protection functions/elements.

**WARNING!**



Check of all temporary blockings:

In order to avoid malfunctions, all blockings related to tripping/non-tripping of protection functions have to be tested.

**NOTICE!**



Prior to the initial operation of the protection device all tripping times and values shown in the adjustment list have to be confirmed by a secondary test

### CAUTION!



In most countries, there are specific national regulations and standards about functional and protection tests that must be carried out on a regular basis.

These must be followed carefully in any case.

#### **Accessories for Commissioning Work**

For commissioning of the protection system, the following accessories should be available:

- For WIC1-1 and WIC1-4: a **DiggiMEC** interface; recommended: a PC with an installed *Smart view* software
- Secondary testing system
- Screwdriver; cross slot type, size 1; 3 mm slot
- Setting parameters

### **8.1.1 Special Features of the WIC1 Test**

For every self-supplied device, it has to be taken into account that the CT has to feed more power than this is the case for protection devices with an additional aux. voltage source. Furthermore, it has to be noted that - with reference to the entire measuring range of the protection devices - the input impedance of the individual phases is not linear.

The WIC1 receives its supply energy out of the measuring circuit. Due to the circuit logic the WIC1 changes its measuring load periodically (with a period of ~1 kHz).

This can have an effect on the feeding source.

### **8.1.2 Selection of the Secondary Test System**

When selecting the secondary test system, the following particulars should be taken into account.

- Secondary test system to be used as current source.
- Three phases for the earth current test, one phase for the phase current test (see [↪ “8.1.5 Functional Test”](#)).
- Sufficient output power for the thresholds to be tested (see [↪ “8.1.5.2 Pickup Thresholds for the Phase Overcurrent Stage I>”](#), [↪ “8.1.5.3 Pickup Thresholds for the Short-Circuit \(Phase Overcurrent\) Stage I>>”](#)).
- The highest possible test current for testing via the test winding is at 22.4 A. A test system with an output current up to 10 A should be sufficient.
- A timer for measuring the time 0 ... 300 s. The time signal can be measured via the WIC1 outputs TC+/TC- or FI+/FI- (WIC1-4: Out+/Out-) as positive edge of a 24 V signal.

### 8.1.3 Measurement of the Resistive Burden

The commissioning often involves measuring the resistive burden at the current inputs, so that the impedance on the secondary side is known.

- One method is to disconnect all wirings between the CTs and the WIC1, so that all the resistances can be measured.
- Another method is to disconnect only the WIC1 current measuring inputs and measure the total resistance (i. e. forward wire + CT winding resistance + back wire).

In this case it is helpful to know the CT winding resistance in advance. For the construction type 2, [the values](#) are listed in the [Technical Data](#).

### 8.1.4 Checks During Commissioning

When putting into operation, the wiring and setting of the protection relay should be checked. Here the person doing the commissioning work is assisted by the integrated test windings of the WIC1 protection system, which are on the front of the relay. Hence any wiring jobs as well as actions in the cable connection area can be disregarded.

#### WARNING!



The [test sockets](#) are not usable at all if [Adapter CTs \(1 A or 5 A\)](#) are connected to the WIC1. For such an application, the usual 1 A / 5 A secondary tests have to be carried out.

We have to stress once again that all usual safety measures must also be taken with the Adapter CTs. In particular, always short-circuit the secondary side (i. e. the WIC1 side in this case) of the Adapter CTs before loosening the terminals (to the WIC1). Ignoring this can result in dangerous voltages at the open contacts.

### 8.1.4.1 Test Windings, Test Sockets

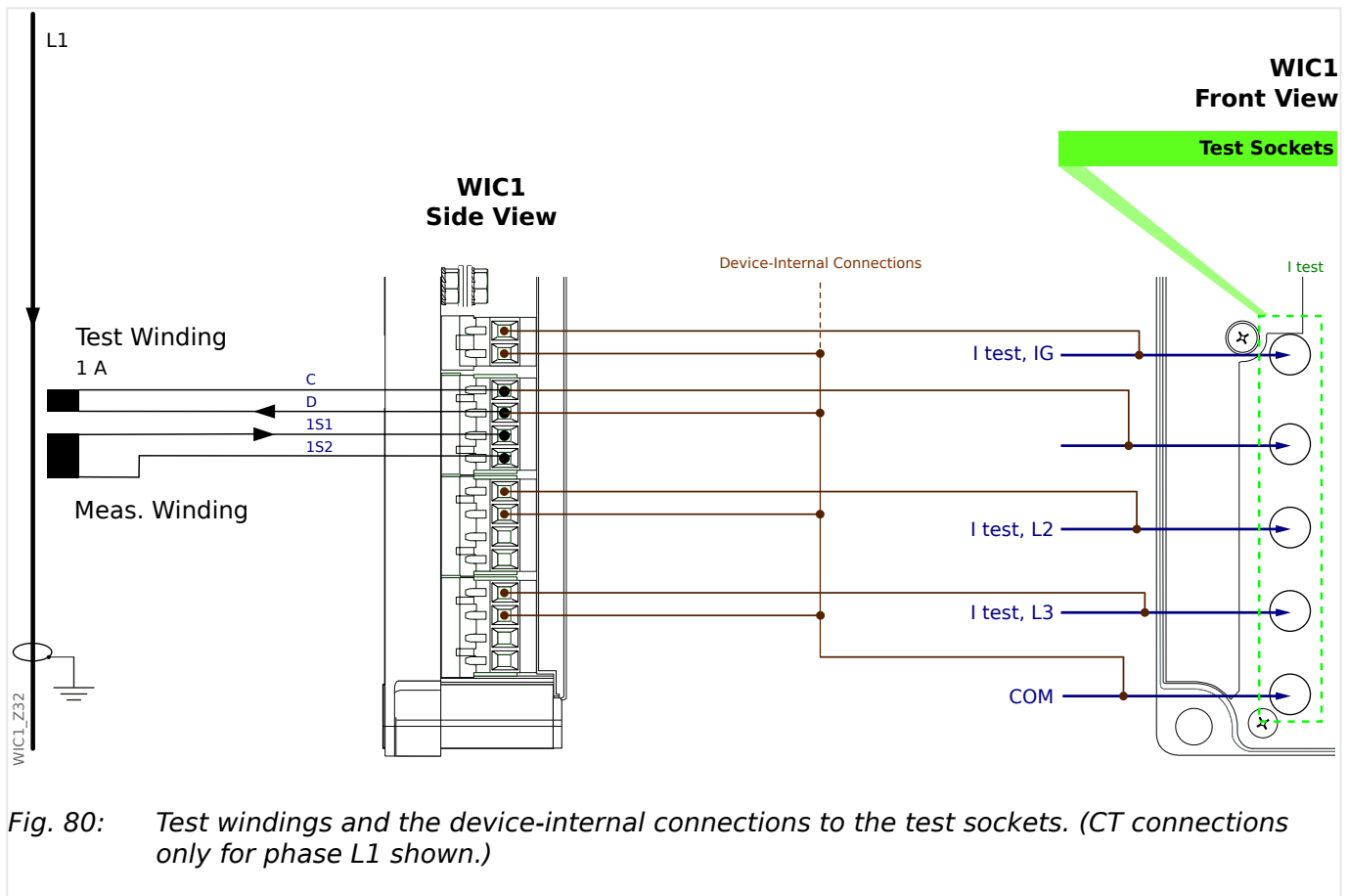

Fig. 80: Test windings and the device-internal connections to the test sockets. (CT connections only for phase L1 shown.)

**This chapter refers only to applications with the WIC1 CTs (WE2, W2,..., W6, because the test sockets cannot be used with the Adapter CTs (1 A or 5 A).)**

The WIC1 uses CTs (see [↳ “2.6.1.3 Order Form of the WIC1-Compatible Current Transformers”](#), [↳ “3.3.2 Selection of a WIC1-Compatible Current Transformer”](#)), with a secondary current that is different from the common values 1 A and 5 A. Therefore it is **not** possible to perform exactly the same tests using the same 1 A / 5 A-testing devices, as with protection devices that are designed for standard CTs.

The usage of standard 1 A testing devices for the secondary test method is possible nonetheless, because the WIC1 CTs have an additional winding that is dedicated for testing purposes. These test windings are connected to the WIC1-terminals C and D for each phase, and there are additional device-internal connections to dedicated test sockets at the front side of the housing.

Via these test sockets, you can inject a test current into the test windings, which results in a simulated primary current. Although this is not a real primary current flowing out of the site to be protected, it induces a current on the secondary side of the CT. Every WIC1 CT is designed such that the ratio between test current and secondary current is the same.

**NOTICE!**



- Injecting currents via the test windings has a lower accuracy, compared to injecting primary currents. However, the accuracy should be sufficient for typical commissioning tests, such as testing the wiring or verifying that the protection device operates as required.
- Moreover, there must be no more primary current flowing during this test, because the injected test current adds to the primary current and this spoils the test results.
- Finally it has to be noted that the test windings transfer only a limited current range in a reliably linear manner. See the related [Technical Data](#).

If you have spent care on all this but the measurements are still wrong, then check the wiring of the contacts and the phase sequence. See also the [Troubleshooting entry about wrong measuring and tripping values](#).

CT Type (See also <a href="#">↳ “2.6.1.3 Order Form of the WIC1-Compatible Current Transformers”</a> .)	Prim. Current Range	Injected C-D Test Current	Induced Current
<b>W2, WE2</b>	16 ... 56 A	1 A	50 A
<b>W3</b>	32 ... 112 A	1 A	100 A
<b>W4</b>	64 ... 224 A	1 A	200 A
<b>W5</b>	128 ... 448 A	1 A	400 A
<b>W6</b>	256 ... 896 A	1 A	800 A

Note: A more detailed table of test current and primary current values can be found in [↳ “8.1.5.1 Test Currents”](#).



### 8.1.4.2 Wiring Checks

Wiring has to be checked with the circuitry shown in the diagram below.

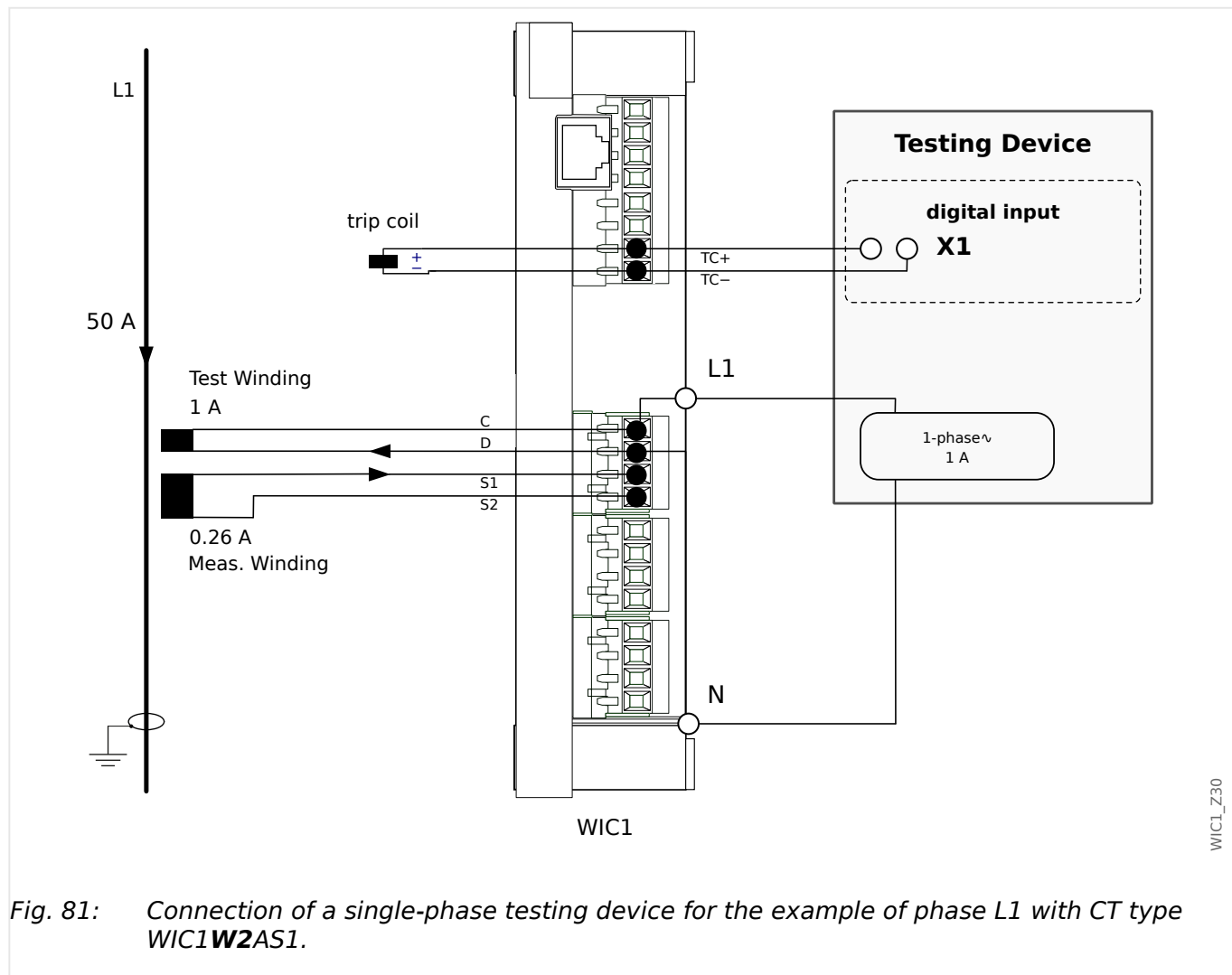

Fig. 81: Connection of a single-phase testing device for the example of phase L1 with CT type WIC1W2AS1.

The testing current is fed via sockets L1, L2, L3 and N. The test winding is rated such that the fed current of 1 A balances a primary current of 50 A (for an example CT type W2 : 16 A ... 56 AAS1).

#### CAUTION!



It is not allowed to connect any active voltage to the trip coil output or to the output (flag indicator / relay output).

The two outputs may be connected at the same time to test equipment (e. g. to binary inputs of an Omicron<sup>®</sup> device) only if these two binary inputs do **not** share a common potential. Otherwise this external potential bridge, together with device-internal circuits, can produce incorrect test results.

**CAUTION!**



For a WIC1-4, it is also necessary that the configured operating mode matches the connected hardware!

(For example, it is not permissible to connect a flag indicator and set the operating mode to “Syst. O.K. & Ext.Suppl.”. See also the related Self-Supervision warnings [SW 3](#), [SW 4](#).)

Moreover, the electrical energy that an output relay drains with operating mode “Syst. O.K. & Ext.Suppl.” requires that the WIC1-4 is supplied by an external auxiliary voltage.

### 8.1.4.3 Self-Supervision Contact for the WIC1-4

An externally supplied WIC1-4 allows for connecting an output relay that operates as a “Healthy” / self-supervision contact. (See [↪](#) “3.8.1 Self-Supervision Contact for the WIC1-4”.)

### 8.1.4.4 WIC1 Settings

The protection parameters must be carefully set, see the respective chapters in this document. For later reference, the setting values can be written directly on the sticker that is affixed on the relay.

### 8.1.5 Functional Test

There are two methods to carry out the tests: Primary test and secondary test.

When the primary test method is used, the test current is impressed via the primary winding.

When the secondary test method is used, the test current is impressed via the C-D test winding, see also [↪](#) “8.1.4.1 Test Windings, Test Sockets”.

### 8.1.5.1 Test Currents

The transformation ratio of primary currents to secondary currents of the CTs are equally proportionate as the test current via the C-D winding to the secondary current. This means, no matter which CT type is in operation, for the secondary test always the same test values are used.

<i>I<sub>n</sub></i>	Test values via C-D winding with the different CT types															
DIP 1-1	OFF	ON	OFF	ON	OFF	ON	OFF	ON	OFF	ON	OFF	ON	OFF	ON	OFF	ON
DIP 1-2	OFF	OFF	ON	ON	OFF	OFF	ON	ON	OFF	OFF	ON	ON	OFF	OFF	ON	ON
DIP 1-3	OFF	OFF	OFF	OFF	ON	ON	ON	ON	OFF	OFF	OFF	OFF	ON	ON	ON	ON
DIP 1-4	OFF	OFF	OFF	OFF	OFF	OFF	OFF	OFF	ON	ON	ON	ON	ON	ON	ON	ON
HEX switch 1	0	1	2	3	4	5	6	7	8	9	A	B	C	D	E	F
» <i>I<sub>n</sub></i> ,relative«	1.0	1.125	1.25	1.375	1.5	1.625	1.75	1.875	2.0	2.125	2.25	2.5	2.75	3.0	3.25	3.5
WIC1-W2 [A]	16	18	20	22	24	26	28	30	32	34	36	40	44	48	52	56
Test current C-D [A]	0.32	0.36	0.40	0.44	0.48	0.52	0.56	0.60	0.64	0.68	0.72	0.80	0.88	0.96	1.04	1.12
WIC1-W3 [A]	32	36	40	44	48	52	56	60	64	68	72	80	88	96	104	112
Test current C-D [A]	0.32	0.36	0.40	0.44	0.48	0.52	0.56	0.60	0.64	0.68	0.72	0.80	0.88	0.96	1.04	1.12
WIC1-W4 [A]	64	72	80	88	96	104	112	120	128	136	144	160	176	192	208	224
Test current C-D [A]	0.32	0.36	0.40	0.44	0.48	0.52	0.56	0.60	0.64	0.68	0.72	0.80	0.88	0.96	1.04	1.12
WIC1-W5 [A]	128	144	160	176	192	208	224	240	256	272	288	320	352	384	416	448
Test current C-D [A]	0.32	0.36	0.40	0.44	0.48	0.52	0.56	0.60	0.64	0.68	0.72	0.80	0.88	0.96	1.04	1.12
WIC1-W6 [A]	256	288	320	352	384	416	448	480	512	544	576	640	704	768	832	896
Test current C-D [A]	0.32	0.36	0.40	0.44	0.48	0.52	0.56	0.60	0.64	0.68	0.72	0.80	0.88	0.96	1.04	1.12

This means when *I<sub>n</sub>* is multiplied with the setting value of the relevant protection element of *I*>, *I*>>, *I*>>> or *IG*>, *IG*>> it equals the test current via the test winding. This is then independent of the CT type. The following tables show all setting values for the protection steps *I*>, *I*>> and *IG*>.

### 8.1.5.2 Pickup Thresholds for the Phase Overcurrent Stage I>

The nominal current  $I_n$  is set via the switches DIP 1-1...1-4 or HEX 1 (independent of the CT type in units of the lower current limit  $I_{n,min}$ ).

Via the switches DIP 2-1...2-4 or HEX 3, the pickup threshold  $I>$  is set, but this is in units of  $I_n$ . (See also [“12.1 Appendix – Settings via DIP / HEX Switches”](#).)

Therefore the pickup threshold  $I>$  in Ampere depends on both DIP 1-1...1-4 / HEX 1 and on DIP 2-1...2-4 / HEX 3, and consequently there is an analogous dependency for the test current (in Ampere) that needs to be fed into the C-D winding. The following table shows this test current (in Ampere):

I>	Setting of the I> threshold															
DIP 2-1	OFF	ON	OFF	ON	OFF	ON	OFF	ON	OFF	ON	OFF	ON	OFF	ON	OFF	ON
DIP 2-2	OFF	OFF	ON	ON	OFF	OFF	ON	ON	OFF	OFF	ON	ON	OFF	OFF	ON	ON
DIP 2-3	OFF	OFF	OFF	OFF	ON	ON	ON	ON	OFF	OFF	OFF	OFF	ON	ON	ON	ON
DIP 2-4	OFF	OFF	OFF	OFF	OFF	OFF	OFF	OFF	ON	ON	ON	ON	ON	ON	ON	ON
HEX switch 3	0	1	2	3	4	5	6	7	8	9	A	B	C	D	E	F*
Resulting setting I> [In] →	0.90	0.95	1.00	1.05	1.10	1.15	1.20	1.30	1.40	1.50	1.60	1.80	2.00	2.25	2.50	— *
Setting for the nominal current $I_n$ [In,min] ↓	Test current via C-D winding [A] ↓															
Hex 1 = „0“ ( $I_n = 1.0$ )	0.288	0.304	0.320	0.336	0.352	0.368	0.384	0.416	0.448	0.480	0.512	0.576	0.640	0.720	0.800	— *
Hex 1 = „1“ ( $I_n = 1.125$ )	0.324	0.342	0.360	0.378	0.396	0.414	0.432	0.468	0.504	0.540	0.576	0.648	0.720	0.810	0.900	— *
Hex 1 = „2“ ( $I_n = 1.25$ )	0.360	0.380	0.400	0.420	0.440	0.460	0.480	0.520	0.560	0.600	0.640	0.720	0.800	0.900	1.000	— *
Hex 1 = „3“ ( $I_n = 1.375$ )	0.396	0.418	0.440	0.462	0.484	0.506	0.528	0.572	0.616	0.660	0.704	0.792	0.880	0.990	1.100	— *
Hex 1 = „4“ ( $I_n = 1.5$ )	0.432	0.456	0.480	0.504	0.528	0.552	0.576	0.624	0.672	0.720	0.768	0.864	0.960	1.080	1.200	— *
Hex 1 = „5“ ( $I_n = 1.625$ )	0.468	0.494	0.520	0.546	0.572	0.598	0.624	0.676	0.728	0.780	0.832	0.936	1.040	1.170	1.300	— *
Hex 1 = „6“ ( $I_n = 1.75$ )	0.504	0.532	0.560	0.588	0.616	0.644	0.672	0.728	0.784	0.840	0.896	1.008	1.120	1.260	1.400	— *
Hex 1 = „7“ ( $I_n = 1.875$ )	0.540	0.570	0.600	0.630	0.660	0.690	0.720	0.780	0.840	0.900	0.960	1.080	1.200	1.350	1.500	— *
Hex 1 = „8“ ( $I_n = 2.0$ )	0.576	0.608	0.640	0.672	0.704	0.736	0.768	0.832	0.896	0.960	1.024	1.152	1.280	1.440	1.600	— *
Hex 1 = „9“ ( $I_n = 2.125$ )	0.612	0.646	0.680	0.714	0.748	0.782	0.816	0.884	0.952	1.020	1.088	1.224	1.360	1.530	1.700	— *
Hex 1 = „A“ ( $I_n = 2.25$ )	0.648	0.684	0.720	0.756	0.792	0.828	0.864	0.936	1.008	1.080	1.152	1.296	1.440	1.620	1.800	— *
Hex 1 = „B“ ( $I_n = 2.5$ )	0.720	0.760	0.800	0.840	0.880	0.920	0.960	1.040	1.120	1.200	1.280	1.440	1.600	1.800	2.000	— *
Hex 1 = „C“ ( $I_n = 2.75$ )	0.792	0.836	0.880	0.924	0.968	1.012	1.056	1.144	1.232	1.320	1.408	1.584	1.760	1.980	2.200	— *
Hex 1 = „D“ ( $I_n = 3.0$ )	0.864	0.912	0.960	1.008	1.056	1.104	1.152	1.248	1.344	1.440	1.536	1.728	1.920	2.160	2.400	— *
Hex 1 = „E“ ( $I_n = 3.25$ )	0.936	0.988	1.040	1.092	1.144	1.196	1.248	1.352	1.456	1.560	1.664	1.872	2.080	2.340	2.600	— *
Hex 1 = „F“ ( $I_n = 3.5$ )	1.008	1.064	1.120	1.176	1.232	1.288	1.344	1.456	1.568	1.680	1.792	2.016	2.240	2.520	2.800	— *

— \* This DIP / HEX setting deactivates the protection stage.

### 8.1.5.3 Pickup Thresholds for the Short-Circuit (Phase Overcurrent) Stage I>>

The nominal current  $I_n$  is set via the switches DIP 1-1...1-4 or HEX 1 (independent of the CT type in units of the lower current limit  $I_{n,min}$ ).

Via the switches DIP 3-1...3-4 or HEX 5, the pickup threshold  $I_{>}$  is set, but this is in units of  $I_n$ . (See also [12.1 Appendix - Settings via DIP / HEX Switches](#).)

Therefore the pickup threshold  $I_{>}$  in Ampere depends on both DIP 1-1...1-4 / HEX 1 and on DIP 3-1...3-4 / HEX 5, and consequently there is an analogous dependency for the test current (in Ampere) that needs to be fed into the C-D winding. The following table shows this test current (in Ampere):

I>>	Setting of the I>> threshold															
DIP 2-1	OFF	ON	OFF	ON	OFF	ON	OFF	ON	OFF	ON	OFF	ON	OFF	ON	OFF	ON
DIP 2-2	OFF	OFF	ON	ON	OFF	OFF	ON	ON	OFF	OFF	ON	ON	OFF	OFF	ON	ON
DIP 2-3	OFF	OFF	OFF	OFF	ON	ON	ON	ON	OFF	OFF	OFF	OFF	ON	ON	ON	ON
DIP 2-4	OFF	OFF	OFF	OFF	OFF	OFF	OFF	OFF	ON	ON	ON	ON	ON	ON	ON	ON
HEX switch 3	0	1	2	3	4	5	6	7	8	9	A	B	C	D	E	F*
Resulting setting I>> [In] →	1	2	3	4	5	6	7	8	9	10	12	14	16	18	20	—*
Setting for the nominal current $I_n$ [In,min] ↓	Test current via C-D winding [A] ↓															
Hex 1 = „0“ ( $I_n = 1.0$ )	0.32	0.64	0.96	1.28	1.60	1.92	2.24	2.56	2.88	3.20	3.84	4.48	5.12	5.76	6.40	—*
Hex 1 = „1“ ( $I_n = 1.125$ )	0.36	0.72	1.08	1.44	1.80	2.16	2.52	2.88	3.24	3.60	4.32	5.04	5.76	6.48	7.20	—*
Hex 1 = „2“ ( $I_n = 1.25$ )	0.40	0.80	1.20	1.60	2.00	2.40	2.80	3.20	3.60	4.00	4.80	5.60	6.40	7.20	8.00	—*
Hex 1 = „3“ ( $I_n = 1.375$ )	0.44	0.88	1.32	1.76	2.20	2.64	3.08	3.52	3.96	4.40	5.28	6.16	7.04	7.92	8.80	—*
Hex 1 = „4“ ( $I_n = 1.5$ )	0.48	0.96	1.44	1.92	2.40	2.88	3.36	3.84	4.32	4.80	5.76	6.72	7.68	8.64	9.60	—*
Hex 1 = „5“ ( $I_n = 1.625$ )	0.52	1.04	1.56	2.08	2.60	3.12	3.64	4.16	4.68	5.20	6.24	7.28	8.32	9.36	10.40	—*
Hex 1 = „6“ ( $I_n = 1.75$ )	0.56	1.12	1.68	2.24	2.80	3.36	3.92	4.48	5.04	5.60	6.72	7.84	8.96	10.08	11.20	—*
Hex 1 = „7“ ( $I_n = 1.875$ )	0.60	1.20	1.80	2.40	3.00	3.60	4.20	4.80	5.40	6.00	7.20	8.40	9.60	10.80	12.00	—*
Hex 1 = „8“ ( $I_n = 2.0$ )	0.64	1.28	1.92	2.56	3.20	3.84	4.48	5.12	5.76	6.40	7.68	8.96	10.24	11.52	12.80	—*
Hex 1 = „9“ ( $I_n = 2.125$ )	0.68	1.36	2.04	2.72	3.40	4.08	4.76	5.44	6.12	6.80	8.16	9.52	10.88	12.24	13.60	—*
Hex 1 = „A“ ( $I_n = 2.25$ )	0.72	1.44	2.16	2.88	3.60	4.32	5.04	5.76	6.48	7.20	8.64	10.08	11.52	12.96	14.40	—*
Hex 1 = „B“ ( $I_n = 2.5$ )	0.80	1.60	2.40	3.20	4.00	4.80	5.60	6.40	7.20	8.00	9.60	11.20	12.80	14.40	16.00	—*
Hex 1 = „C“ ( $I_n = 2.75$ )	0.88	1.76	2.64	3.52	4.40	5.28	6.16	7.04	7.92	8.80	10.56	12.32	14.08	15.84	17.60	—*
Hex 1 = „D“ ( $I_n = 3.0$ )	0.96	1.92	2.88	3.84	4.80	5.76	6.72	7.68	8.64	9.60	11.52	13.44	15.36	17.28	19.20	—*
Hex 1 = „E“ ( $I_n = 3.25$ )	1.04	2.08	3.12	4.16	5.20	6.24	7.28	8.32	9.36	10.40	12.48	14.56	16.64	18.72	20.80	—*
Hex 1 = „F“ ( $I_n = 3.5$ )	1.12	2.24	3.36	4.48	5.60	6.72	7.84	8.96	10.08	11.20	13.44	15.68	17.92	20.16	22.40	—*

— \* This DIP / HEX setting deactivates the protection stage.

## 8.1.6 Special Features for Tests of Calculated Ground (Earth) Overcurrent

### ***Functional Description***

Depending on the WIC1 settings, the ground (earth) current can be calculated instead of being measured. Then it is established from the geometrical amount of the three phase current values, more or less a numerical Holmgreen. If, for instant, a single-phase test current is impressed, the measuring value (tripping value) in the ground (earth) current path equals the current in the tested phase. If, with a phase shift of  $120^\circ$  a three-phase test current is impressed, the measuring value in the ground (earth) current path equals zero.

### ***Requirement for the Test System***

The WIC1 is powered by the phase CTs. In order to guarantee a reliable tripping a minimal current has to flow, see [↳ “10.1.6 Power Supply”](#). If the setting of the ground overcurrent threshold  $I_{G>}$  is lower than the smallest possible 1-phase supply via the phase CTs, then the ground current tripping can only be tested by a three-phase current source. Only if the set ground overcurrent threshold is higher than the smallest possible 1-phase supply via the phase CTs, then the test can be performed with a single-phase current source.

### 8.1.6.1 Tripping Thresholds for the Calculated Ground Overcurrent Stage IG>

NOTICE!

The device variants WIC1-xx**G** feature a ground (earth) current measuring input, and both measuring input and test winding is for 1 A rated ground (earth) current. (This means the test winding simply has a 1:1-ratio.) The values for the test current via C-D winding in the following table are therefore **not** valid for these device variants. (Or, strictly speaking, they can be used if the WIC1 has been set to calculated ground (earth) current DiggiMEC/Smart view but then the DIP/HEX switch settings listed below are invalid)!

In other words: The following description and values about commissioning the ground (earth) overcurrent protection refers to device variants WIC1-xx**N** without ground (earth) current measuring input.

The nominal current  $I_n$  is set via the switches DIP 1-1...1-4 or HEX 1 (independent of the CT type in units of the lower current limit  $I_{n,min}$ ).

Via the switches DIP 4-1...4-4 or HEX 7, the pickup threshold  $I_{G>}$  is set, but this is in units of  $I_n$ . (See also [↪ “12.1 Appendix - Settings via DIP / HEX Switches”](#).)

Therefore the pickup threshold  $I_{G>}$  in Ampere depends on both DIP 1-1...1-4 / HEX 1 and on DIP 4-1...4-4 / HEX 7, and consequently there is an analogous dependency for the test current (in Ampere) that needs to be fed into the C-D winding. The following table shows this test current (in Ampere):

IG>	Setting of the IG> threshold															
DIP 4-1	OFF	ON	OFF	ON	OFF	ON	OFF	ON	OFF	ON	OFF	ON	OFF	ON	OFF	ON
DIP 4-2	OFF	OFF	ON	ON	OFF	OFF	ON	ON	OFF	OFF	ON	ON	OFF	OFF	ON	ON
DIP 4-3	OFF	OFF	OFF	OFF	ON	ON	ON	ON	OFF	OFF	OFF	OFF	ON	ON	ON	ON
DIP 4-4	OFF	OFF	OFF	OFF	OFF	OFF	OFF	OFF	ON	ON	ON	ON	ON	ON	ON	ON
HEX switch 7	0	1	2	3	4	5	6	7	8	9	A	B	C	D	E	F *
Resulting setting IG>	0.2	0.3	0.4	0.5	0.6	0.7	0.8	0.9	1	1.2	1.4	1.6	1.8	2.0	2.5	— *
[In] →																
Setting for the nominal current $I_n$	Test current via C-D winding															
[In,min]	[A]															
↓	↓															
Hex 1 = „0“ ( $I_n = 1.0$ )	0.064	0.096	0.128	0.160	0.192	0.224	0.256	0.288	0.320	0.384	0.448	0.512	0.576	0.640	0.800	— *
Hex 1 = „1“ ( $I_n = 1.125$ )	0.072	0.108	0.144	0.180	0.216	0.252	0.288	0.324	0.360	0.432	0.504	0.576	0.648	0.720	0.900	— *
Hex 1 = „2“ ( $I_n = 1.25$ )	0.080	0.120	0.160	0.200	0.240	0.280	0.320	0.360	0.400	0.480	0.560	0.640	0.720	0.800	1.000	— *
Hex 1 = „3“ ( $I_n = 1.375$ )	0.088	0.132	0.176	0.220	0.264	0.308	0.352	0.396	0.440	0.528	0.616	0.704	0.792	0.880	1.100	— *
Hex 1 = „4“ ( $I_n = 1.5$ )	0.096	0.144	0.192	0.240	0.288	0.336	0.384	0.432	0.480	0.576	0.672	0.768	0.864	0.960	1.200	— *
Hex 1 = „5“ ( $I_n = 1.625$ )	0.104	0.156	0.208	0.260	0.312	0.364	0.416	0.468	0.520	0.624	0.728	0.832	0.936	1.040	1.300	— *
Hex 1 = „6“ ( $I_n = 1.75$ )	0.112	0.168	0.224	0.280	0.336	0.392	0.448	0.504	0.560	0.672	0.784	0.896	1.008	1.120	1.400	— *
Hex 1 = „7“ ( $I_n = 1.875$ )	0.120	0.180	0.240	0.300	0.360	0.420	0.480	0.540	0.600	0.720	0.840	0.960	1.080	1.200	1.500	— *
Hex 1 = „8“ ( $I_n = 2.0$ )	0.128	0.192	0.256	0.320	0.384	0.448	0.512	0.576	0.640	0.768	0.896	1.024	1.152	1.280	1.600	— *
Hex 1 = „9“ ( $I_n = 2.125$ )	0.136	0.204	0.272	0.340	0.408	0.476	0.544	0.612	0.680	0.816	0.952	1.088	1.224	1.360	1.700	— *
Hex 1 = „A“ ( $I_n = 2.25$ )	0.144	0.216	0.288	0.360	0.432	0.504	0.576	0.648	0.720	0.864	1.008	1.152	1.296	1.440	1.800	— *
Hex 1 = „B“ ( $I_n = 2.5$ )	0.160	0.240	0.320	0.400	0.480	0.560	0.640	0.720	0.800	0.960	1.120	1.280	1.440	1.600	2.000	— *
Hex 1 = „C“ ( $I_n = 2.75$ )	0.176	0.264	0.352	0.440	0.528	0.616	0.704	0.792	0.880	1.056	1.232	1.408	1.584	1.760	2.200	— *

## 8 Commissioning

### 8.1.6.1 Tripping Thresholds for the Calculated Ground Overcurrent Stage IG>

IG>	Setting of the IG> threshold															
DIP 4-1	OFF	ON	OFF	ON	OFF	ON	OFF	ON	OFF	ON	OFF	ON	OFF	ON	OFF	ON
DIP 4-2	OFF	OFF	ON	ON	OFF	OFF	ON	ON	OFF	OFF	ON	ON	OFF	OFF	ON	ON
DIP 4-3	OFF	OFF	OFF	OFF	ON	ON	ON	ON	OFF	OFF	OFF	OFF	ON	ON	ON	ON
DIP 4-4	OFF	OFF	OFF	OFF	OFF	OFF	OFF	OFF	ON	ON	ON	ON	ON	ON	ON	ON
HEX switch 7	0	1	2	3	4	5	6	7	8	9	A	B	C	D	E	F *
Resulting setting IG> [In] →	0.2	0.3	0.4	0.5	0.6	0.7	0.8	0.9	1	1.2	1.4	1.6	1.8	2.0	2.5	— *
Hex 1 = „D“ (In = 3.0)	0.192	0.288	0.384	0.480	0.576	0.672	0.768	0.864	0.960	1.152	1.344	1.536	1.728	1.920	2.400	— *
Hex 1 = „E“ (In = 3.25)	0.208	0.312	0.416	0.520	0.624	0.728	0.832	0.936	1.040	1.248	1.456	1.664	1.872	2.080	2.600	— *
Hex 1 = „F“ (In = 3.5)	0.224	0.336	0.448	0.560	0.672	0.784	0.896	1.008	1.120	1.344	1.568	1.792	2.016	2.240	2.800	— *

— \* This DIP / HEX setting deactivates the protection stage.



## 8.2 Putting out of Operation – Plug out the Relay

### WARNING!



Warning! Dismounting the relay will lead to a loss of the protection functionality. Ensure that there is a back-up protection. If you are not aware of the consequences of dismantling the device – stop! Don't start.

### WARNING!



Inform SCADA before you start.

Switch off the power supply (if connected).

Ensure that the cabinet is dead and that there are no voltages that could lead to personal injury. Always short-circuit current transformers before loosening the terminals.

Use a screw-driver to plug out the cables.

Fasten the cables and terminals in the cabinet by means of cable clips to ensure that no accidental electrical connections are caused.

Hold the device at the front-side while opening the mounting nuts.

Remove the device carefully out of the cabinet.

In case no other device is to be mounted or replaced cover/close the cut-out in the front-door.

Close the cabinet.

## 8.3 Restart of the WIC1

Within the menu [Service / General] »Sys . User Restart«, the user can initiate a reboot of the WIC1.



The »System OK« LED is constantly green if – after the boot phase – the protection functions of the WIC1 are working and there is enough energy for issuing a trip signal.

More information can be found in [↪ “3.9.1 LEDs”](#) and in [↪ “11 Troubleshooting”](#).

## 8.4 Measuring the Trip Delay

Variants of type WIC1-xxxxC offer a freely configurable impulse output for a flag indicator. (See [“3.8 Outputs \(Trip Coil, Flag Indicator, Relay Output\)”](#) and the [Order Options](#).)

Although this FI output has its primary use in triggering a flag indicator it can also be used for special testing purposes if it is configurable; for example, it can be connected to the digital input of a testing device. If the TC (trip coil impulse output) is then connected to another digital input, then the testing device is able to measure the trip delay (i. e. the time-span between pickup and trip).

### Hardware

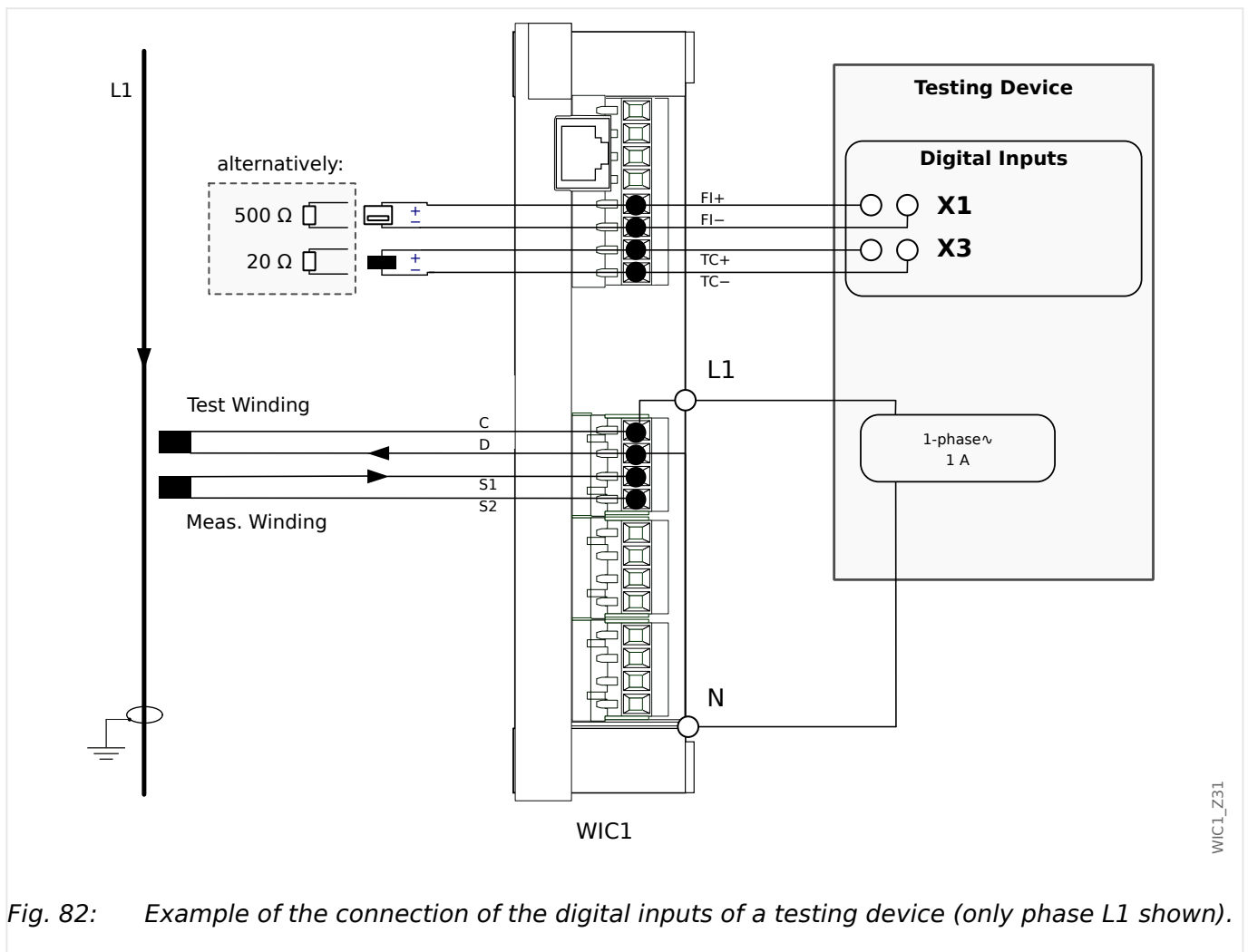

Fig. 82: Example of the connection of the digital inputs of a testing device (only phase L1 shown).

When connecting the impulse outputs for Trip Coil and Flag Indicator to the digital inputs of the testing device, there are important rules to be followed:

### CAUTION!



In the Hardware settings of the testing device, set up the digital inputs so that they accept an input voltage between 17 VDC and 24 VDC as “binary 1”.

This means, in particular, that these digital inputs must not be defined as “potential-free”.

### CAUTION!



It is not allowed to connect any active voltage to the trip coil output or to the output (flag indicator / relay output).

The two outputs may be connected at the same time to test equipment (e. g. to binary inputs of an Omicron<sup>®</sup> device) only if these two binary inputs do **not** share a common potential. Otherwise this external potential bridge, together with device-internal circuits, can produce incorrect test results.

### CAUTION!



For a WIC1-4, it is also necessary that the configured operating mode matches the connected hardware!

(For example, it is not permissible to connect a flag indicator and set the operating mode to “Syst. O.K. & Ext.Suppl.”. See also the related Self-Supervision warnings [SW 3](#), [SW 4](#).)

Moreover, the electrical energy that an output relay drains with operating mode “Syst. O.K. & Ext.Suppl.” requires that the WIC1-4 is supplied by an external auxiliary voltage.

### **WIC1 Settings**

The “TC” (Trip Coil) output is always mapped to the trip command, i. e. to the digital signal »Prot . TripCmd«. (See also [↔ “5.1 »Prot« - General Protection Module”](#).)

For measuring the trip delay, the “FI” (Flag Indicator) output is set as follows:

- [Device Para / WIC1 / Output] »Prot . Out. assign.« = “Prot . Pickup”

### **Testing Device Settings**

Finally, you can use the operating software of your testing device to measure the time-span between the two digital inputs. This is straight-forward for all recent testing devices.

## 9 Servicing and Maintenance

The entire protection system WIC1 is designed for a maintenance-free period of 25 years, hence there are no specific jobs necessary to be done during the operating life of the relays.

However, very often a periodical check of the protection functionality is required by the end user or by legal directives. Such checks can then be carried out as described in [↪ “8.1 Commissioning / Protection Test”](#).

## 10 Technical Data

### 10.1 Technical Data - WIC1

#### NOTICE!



Use an Ethernet cable CAT 3 (or better) with shielding for the connection between WIC1 and DiggiMEC. **Crossover cables must not be used!**

#### 10.1.1 Climatic and Environmental Data

Storage Temperature:	-40°C to +85°C (-40°F to 185°F)
Operating Temperature:	<ul style="list-style-type: none"> <li>• WIC1-1, WIC1-2, WIC1-3: -40°C to +80°C (-40°F to 176°F)</li> <li>• WIC1-4: -40°C to +60°C (-40°F to 140°F)</li> </ul>
Permissible Humidity at Ann. Average:	≤ 75% rel. (on 56 days up to 95% rel.)
Permissible Installation Altitude:	≤ 2000 m (6561.67 ft) above sea level

#### 10.1.2 Housing

Housing (Height / Width / Depth): (see also dimension drawings in <a href="#">↳ "3.2 Dimension Drawings"</a> )	170 mm (6.693 in.) / 125 mm (4.921 in.) / 39.8 mm (1.567 in.)
Material, Housing:	Aluminum. Cover of terminals: plastic
Weight:	<ul style="list-style-type: none"> <li>• WIC1 (without packaging): approx. 940 g</li> <li>• WIC1 (incl. packaging): approx. 1100 g</li> </ul>

#### 10.1.3 Degree of Protection EN 60529

Housing	IP40
Electronic circuit	IP65
Terminals	IP20

### 10.1.4 Phase Current Measurement

The measuring inputs for phase currents are matching the allocated CTs. Moreover, the power requirement of the relay and the CT output power match.

<b>CAUTION!</b>	
	It is not permissible to connect common CTs with secondary currents of 1 A or 5 A to the measuring inputs.

Nominal frequency:	50 Hz / 60 Hz
Nominal Current (at the CT inputs of the WIC1):	83.33 mA 75 mA at $I_n = 0.9 I_{n,min}$  Remark: These values equal in every respect the nominal current data of the previous/ original version of the WIC1 so that full compatibility is guaranteed.
Max. Measuring Range:	20 × highest rated CT current
Capacity:	permanently: 2.5 × highest rated CT current
Thermal load capacity:	1 s: 25 kA CT primary current
Screws	<ul style="list-style-type: none"> <li>Inputs for <b>WIC1</b> CTs:  M3 slotted, tightening torque 0.5 Nm (4.4 lb·in)</li> </ul>

### 10.1.5 Ground Current Measurement

<b>CAUTION!</b>	
	The measuring input for ground (earth) current is permissible only for a CT with secondary current of 1 A.

<b>Ground Current Input:</b>	
Nominal Current:	1 A
Max. Measuring Range:	Up to 20 x $I_n$
Capacity:	4 x $I_n$ /continuously
Overcurrent Proof:	50 x $I_n$ / 1 s

<b>Ground Current Input:</b>	
Power Consumption:	$S \leq 0.1 \text{ VA}$

## 10.1.6 Power Supply

### *Supply via CTs*

- Minimum supply current, 1 Phase:  $0.35 I_{n,\min}$
- Minimum supply current, 3 Phases:  $0.25 I_{n,\min}$

### *Auxiliary Power Supply (WIC1-4)*

Aux. Voltage:	<ul style="list-style-type: none"> <li>• 18 ... 300 VDC</li> <li>• 40 ... 250 VAC</li> </ul>
Buffer Time in Case of Supply Failure:	<p><math>\geq 50 \text{ ms}</math> at minimal aux. voltage</p> <p>The device will shut down if the buffer time is expired.</p> <p>Note: communication can be interrupted.</p>

The auxiliary voltage supply must be protected by an external fuse of:

- 2.5 A time-lag miniature fuse 5 x 20 mm (approx. 1/5 x 0.8 in.) according to IEC 60127
- 3.5 A time-lag miniature fuse 6.3 x 32 mm (approx. 1/4 x 1 1/4 in.) according to UL 248-14

## 10.1.7 LEDs

LED type:	1 green LED, 2 red LEDs
-----------	-------------------------

## 10.1.8 Outputs

### **CAUTION!**



It is not allowed to connect any active voltage to the trip coil output or to the output (flag indicator / relay output).

The two outputs may be connected at the same time to test equipment (e. g. to binary inputs of an Omicron<sup>®</sup> device) only if these two binary inputs do **not** share a common potential. Otherwise this external potential bridge, together with device-internal circuits, can produce incorrect test results.

**CAUTION!**



For a WIC1-4, it is also necessary that the configured operating mode matches the connected hardware!

(For example, it is not permissible to connect a flag indicator and set the operating mode to “Syst. O.K. & Ext.Suppl.”. See also the related Self-Supervision warnings [SW 3](#), [SW 4](#).)

Moreover, the electrical energy that an output relay drains with operating mode “Syst. O.K. & Ext.Suppl.” requires that the WIC1-4 is supplied by an external auxiliary voltage.

**10.1.8.1 Impulse Output for the Tripping Coil**

The low-energy trip coil of the circuit breaker is connected to terminals TC+ and TC– of the terminal block X4. The trip energy is provided by a capacitor store integrated in the protection relay. See also [↳ “5.1.1.1 Trip Pulse and WIC1 LEDs”](#).

Length of each trip impulse:	(approx.) 50 ms  The pause between the individual pulses depends on the impedance of the tripping coil and the current level. Pulsing is continued until the protection function’s tripping state drops off.
Trip energy:	$E \geq 0.1 \text{ Ws}$
Voltage:	24 VDC nominal voltage

Examples for compatible low energy trip coils:

- Manufacturer Siemens, type: 3AX 1104-0B; (0.1 Ws; 10 Ω)
- Manufacturer Siemens, type: 3AX 1104-2B; (0.1 Ws; 20 Ω)

**10.1.8.2 Impulse Output for a Flag Indicator**

Depending on the [order option](#), the WIC1 can feature an impulse output for a flag indicator.

A flag indicator can be connected to terminals FI+/- (WIC1-4: Out+/-) of the terminal block X4, e. g. for a power-safe signaling of a trip. See also [↳ “3.8.3 Impulse Signal for the Flag Indicator”](#).

Length of each trip impulse:	(approx.) 50 ms  The pause between the individual pulses depends on the impedance of the flag indicator and the current level. Pulsing is continued until the protection function’s tripping state drops off.
Energy:	$\geq 0.01 \text{ Ws}$
Voltage:	24 VDC nominal voltage



### 10.1.8.3 Relay Output (WIC1-4)

With the device variant WIC1-4, it is possible via setting [Device Para / WIC1 / Output] »Prot. Out. Mode« = "Syst. O.K. & Ext.Suppl." to set the output "Out+/-" up for connecting an external output relay.

This output relay must fulfill the following conditions:

Nominal voltage of the coil:	24 VDC, max. 36 VDC No internal overvoltage protection allowed
Input current:	max. 10 mA
Wiring length:	max. 5 m

Example of a usable output relay: Phoenix Relay Module – RIF-0-RSC-24DC/21 – 2903374

### 10.1.9 Remote (External) Trip Input / Digital Input (WIC1-1, WIC1-2, WIC1-3)

A device of type WIC11, WIC12, WIC13 can feature a Digital Input (depending on the [order option](#)).

To the terminals X4-2, X4-3, X4-4 (for the connection of 230 VAC, 115 VAC, COM, resp., see [↳ "3.5 Digital Input \(only WIC1-1... / WIC1-2... / WIC1-3...\)"](#)) of the terminal block X4 the relevant signaling AC voltage for the input is connected. This input is electrically isolated.

#### CAUTION!



It is not allowed to connect any continuous voltage to the 115 VAC or 230 VAC input!  
Any continuous voltage can destroy the internal signal transformer.

Input voltage range, 115 Volt terminal:	<ul style="list-style-type: none"> <li>If operated up to max. 3000 m (above sea-level): 115 VAC ± 15%</li> </ul>
Input voltage range, 230 Volt terminal:	<ul style="list-style-type: none"> <li>230 VAC ± 15% (d. h. 195,5 V ... 264,5 V)</li> </ul> <p>An operation above 3500 m (above sea-level) is outside the specifications and therefore not permitted.</p>
Terminals:	Screw-type terminal
Reaction Time:	<ul style="list-style-type: none"> <li>&lt; 20 ms (*)</li> </ul>

Tripping time of the <b>External Protection</b> in case of a cold restart:	≤ 0.5 s
--	---------

(\*) The reaction times have been measured with a WIC1 that is ready to trip (i. e. green Ready LED is lit). They are the time-span for the **External Protection** from activation of the trigger signal until activation of the “TC+/-” impulse output.

### 10.1.10 Digital Inputs (WIC1-4)

A device of type WIC1-4 can feature 2 Digital Inputs (depending on the [order option](#)). For variants WIC1-4xxxx**F** there is a fixed assignment to “External Trip” and “External Reset”, respectively. For variants WIC1-4xxxx**C**, this is a default assignment that can be re-defined.

The Digital Inputs are **not** potential-free, i. e. they are not isolated from the housing and from the internal electronics. Moreover, the two Digital Inputs of the WIC14 are *grouped*, i. e. share a common electrical potential.

The input voltage range can be selected by software parametrization.

Voltage Range	Nominal Voltage	Digital “Low” / “0” below 0.4 Vn  (20% below switching threshold)	Switching Threshold at 0.6 Vn (± 20%)	Digital “High” / “1” above 0.8Vn  (20% above switching threshold)
24 VDC	24.0 VDC	9.6 VDC	14.4 VDC	19.2 VDC
48 VDC ... 60 VDC	52.0 VDC	20.8 VDC	31.2 VDC	41.6 VDC
110 VDC / 110 VAC	110.0 VDC / 110.0 VAC	44.0 VDC / 44.0 VAC	66.0 VDC / 66.0 VAC	88.0 VDC / 88.0 VAC
230 VDC / 230 VAC	220.0 VDC / 220.0 VAC	88.0 VDC / 88.0 VAC	132.0 VDC / 132.0 VAC	176.0 VDC / 176.0 VAC

Terminals:	Screw-type terminal
Max. Input Voltage:	300 VDC / 259 VAC
Input Current:	< 1 mA
Reaction Time:	<ul style="list-style-type: none"> <li>• for DC: &lt; 10 ms (*)</li> <li>• for AC: &lt; 20 ms (*)</li> </ul>

(\*) The reaction times have been measured with a WIC1 that is ready to trip (i. e. green Ready LED is lit). They are the time-span for the **External Protection** from activation of the trigger signal until activation of the “TC+/-” impulse output.

### 10.1.11 Smart view Connections

The WIC1 can communicate with the operating software *Smart view* via a USB connection to a DigiMEC. (See also [Fig. in “2.7 Settings - Operation”](#).)

The DigiMEC is an [optional separate accessory](#).

- Use a standard network (Ethernet) cable to connect the WIC1 with the DiggiMEC. (See [↪ “2.7 Settings - Operation”](#).)

(Note, however, that the communication between WIC1 and DiggiMEC is based on a proprietary protocol.)





### 10.1.12 Self-Supervision Messages

The storage capacity for Self-Supervision messages (see [↪ “7.2 Self-Supervision Messages”](#)) is as follows:

- **E** - Errors - up to 37 messages. Each new error beyond this number deletes the oldest error message.
- **W** - Warnings - up to 25 messages. Each new warning beyond this number deletes the oldest warning message.
- **I** - Information messages - up to 25 messages. Each new information message beyond this number deletes the oldest information message.

### 10.1.13 Standards - WIC1

#### 10.1.13.1 Approvals

	
	
	UL File Nr.: E217753 cULuc Certification of WIC1 and DiggiMEC - UL508, E217753 - NRGU
	EAC certified by EAC (Eurasian Conformity)

### 10.1.13.2 Design Standards

<p>Generic standards</p>	<p>2014/35/EU (2014-02-26, on the harmonisation of the laws of the Member States relating to making available on the market of electrical equipment designed for use within certain voltage limits)</p> <p>2014/30/EU (2014-02-26, on the harmonisation of the laws of the Member States relating to electromagnetic compatibility)</p> <p>2011/65/EU (2011-06-08, on the restriction of the use of certain hazardous substances in electrical and electronic equipment, with the following allowed exemptions: 6(a), 6(a)-I, 6(c), 7(a), 7(c)-I)</p> <p>2015/863/EU (2015-03-31, amending Annex II to Directive 2011/65/EU of the European Parliament and of the council as regards the list of restricted substances)</p>
<p>Product standards</p>	<p>IEC 60255-1, 2009</p> <p>IEC 60255-26, 2013</p> <p>IEC 60255-27, 2013</p>

**10.1.13.3 Electrical Tests**

**EMC Tests**

<b>Electrical Discharge Immunity Test (ESD)</b>		
IEC 60255-26 [03/14]	Air discharge	8 kV
DIN EN 61000-4-2 [12/09] class 3	Contact discharge	6 kV
<b>Fast Transient Disturbance Immunity Test (Burst)</b>		
IEC 60255-26 [03/14]	Power supply, mains inputs	±4 kV, 2.5 kHz
DIN EN 61000-4-4 [04/13] class 4	Other in- and outputs	±2 kV, 5 kHz
<b>Interference immunity against 1 MHz burst disturbance tests</b>		
IEC 60255-26 [03/14]	differential mode	2.5 kV, 1 MHz
DIN EN 61000-4-18 [09/20]	common mode	1 kV, 2 s
<b>Interference immunity against surge immunity test</b>		
IEC 60255-26 [03/14]		4 kV / 2 kV
DIN EN 61000-4-5 [03/19]		
<b>Interference immunity against high-frequent electromagnetic fields</b>		
IEC 60255-26 [03/14]		30 V/m
DIN EN 61000-4-3 [04/11]		
<b>Interference immunity against magnetic fields of energy based frequency</b>		
IEC 60255-26 [03/14]	continuously	100 A/m
DIN EN 61000-4-8 [11/10]	3 s	1000 A/m
<b>Interference immunity against line conducted interference quantities induced by high-frequent fields</b>		
IEC 60255-26 [03/14]		10 V/m
DIN EN 61000-4-6 [08/14]		

**Interference immunity against surge voltage**

IEC 60255-26 [03/14]	within a current circuit	1 kV
IEC 60255-27 [11/14]	current circuit to earth	5 kV

**Measuring of the radio interference voltage**

DIN EN 55011 [05/18]		Limit value class B
----------------------	--	---------------------

**Measuring of the radio interference radiation**

DIN EN 55011 [05/18]		Limit value class B
----------------------	--	---------------------

**10.1.13.4 Safety-Related Tests**

Overvoltage category	IEC 60255-27 [11/14]	III
Pollution degree	IEC 60255-27 [11/14]	3
Protection class	IEC 60255-27 [11/14]	II
Test of withstand alternating voltage for 1 min	IEC 60255-27 [11/14]	4 kV / 1 kV
Test of lightning surge voltage 1.2/50 $\mu$ s, 0.5 J	IEC 60255-27 [11/14]	5 kV / 1 kV
Inflammability	IEC 60255-27 [11/14]	rated
Single Defect Condition	IEC 60255-27 [11/14]	rated



### 10.1.13.5 Environmental Tests

Vibration and continuous vibration test:	IEC 60255-27 [11/14]	1 / 2 gn
	DIN EN 60255-21-1 [05/96]	Class 2
Shock and continuous shock test:	IEC 60255-27 [11/14]	10 / 20 gn
	DIN EN 60255-21-2 [05/96]	Class 2

#### **Classification:**

IEC 60255-27 [11/14] DIN EN 60068-1 [09/15]	Climate category	<ul style="list-style-type: none"> <li>• WIC1-1, WIC1-2, WIC1-3: 40/085/10</li> <li>• WIC1-4: 40/060/10</li> </ul>
--	------------------	--

#### **Test Ad: Kälte**

IEC 60255-27 [11/14]	Temperature	−40°C
DIN EN 60068-2-1 [01/08]	Period of stress	16 h

#### **Test Bd: Dry heat**

IEC 60255-27 [11/14] DIN EN 60068-2-2 [07/07]	Temperature	<ul style="list-style-type: none"> <li>• WIC1-1, WIC1-2, WIC1-3: +85°C (185°F)</li> <li>• WIC1-4: +60°C (140°F)</li> </ul>
	Rel. humidity	<50%
	Period of stress	72 h

#### **Test Cab: Humid heat (constantly)**

IEC 60255-27 [11/14]	Temperature	+60°C (140°F)
IEC 60068-2-78 [02/14]	Rel. humidity	93%
	Period of stress	10 Tage

**Test Db: Humid heat (cyclic)**

IEC 60255-27 [11/14]	Temperature	<ul style="list-style-type: none"> <li>• WIC1-1, WIC1-2, WIC1-3: +85°C (185°F)</li> <li>• WIC1-4: +60°C (140°F)</li> </ul>
IEC 60068-2-30 [06/06]	Rel. humidity	95%
	Cycles (12 + 12 hours)	2

## 10.2 Tolerances / Accuracy - WIC1

### NOTICE!



The tripping delay relates to the time between alarm and trip. The accuracy of the operating time relates to the time between fault entry and the time when the protection element is picked-up.

### 10.2.1 Protection Elements Accuracy

Reference conditions for all protection elements:

- sine wave at rated frequency (50 Hz / 60 Hz),
- THD < 1%, measuring method: fundamental,
- Load current / supply:
  - either: minimum current in 3 phases >  $0.35 \cdot I_{n_{min}}$  for at least 1 s,
  - or: externally supplied (only WIC1-4).

#### 10.2.1.1 Phase Overcurrent Protection

Overcurrent Protection Stages <i>I&gt;, I&gt;&gt;, I&gt;&gt;&gt;</i>	Accuracy
Pickup value »I« for $I > 0.5 I_n$	$\pm 5\%$ of the setting value or $\pm 5\% I_n$ .
Dropout Ratio	95%

Overcurrent Protection Stages <i>I&gt;, I&gt;&gt;, I&gt;&gt;&gt;</i> <b>Definite time</b> »Char« = "DEFT"	Accuracy
Tripping delay »t«	$\pm 1\%$ or $\pm 10$ ms
Operate time (for »t« = 0 ms) at testing current $\geq 2$ times pickup value	$< 30$ ms *1) *2) *3)
Operate time (for »t« = 0 ms) at testing current $\geq 2$ times pickup value and pickup value $\geq 1,1 \cdot I_n$	22 ms typical

<b>Overcurrent Protection Stages</b> <b>I&gt;, I&gt;&gt;, I&gt;&gt;&gt;</b> <b>Inverse-Time / Characteristic curve</b>	<b>Accuracy</b>
Start time (pickup time) At testing current $\geq 2$ times pickup value	$< 30 \text{ ms}^{*1) *2) *3)}$
Tripping delay For testing current in the range 2 ... 20 times pickup value	$\pm 5\%$ or $\pm 30 \text{ ms}$ (according to the selected curve, see <a href="#">↪ "12.2.1 Characteristics (I&gt;, I&gt;&gt;, I&gt;&gt;&gt;)"</a> )
Operate time	$= \text{Start time} + \text{Tripping delay}$

\*1) These start / pickup times are only valid under the following conditions:

- either: minimum current in 3 phases  $> 0.35 \cdot I_{n_{min}}$  for at least 1 s,
- or: externally supplied (only WIC1-4).

\*2) While being CT-supplied, the start times might be longer because the WIC1 has to collect enough electrical energy for a trip pulse. See also [↪ "10.2.2 Measured Trip Times \(fN = 50 Hz, 1-/3-phase\)"](#).

\*3) if the protection stage is used together with [Inrush Blocking](#) it is necessary to set the tripping delay to at least 30 ms.

### 10.2.1.2 Ground (Earth) Overcurrent Protection

(Measurement of ground (earth) current is not available for all device variants.)

Ground (Earth) Current Protection Stages IG>, IG>>	Accuracy
Pickup value »IG« for measured ground (earth) current and IG within 0.02 ... 10 In:	±2% of the setting value or ±2% In.
Pickup value »IG« for calculated ground (earth) current and I within 0.35 ... 10 In *4)	<ul style="list-style-type: none"> <li>±3% of the greatest phase current value or ±9% of the setting value.</li> <li>with setting »Measuring method« = "True RMS":  ±15% of the setting value.</li> </ul>
Dropout Ratio	95%

Ground (Earth) Current Protection Stages IG>, IG>>	Accuracy
<b>Definite time</b> »Char« = "DEFT"	
Tripping delay »t«	±1% or ±10 ms
Operate time (for »t« = 0 ms) at testing current ≥ 2 times pickup value	<40 ms *1) *2) *3)

Ground (Earth) Current Protection Stages IG>, IG>>	Accuracy
<b>Inverse-Time / Characteristic curve</b>	
Start time (pickup time) At testing current ≥ 2 times pickup value	<40 ms *1) *2) *3)
Tripping delay For testing current in the range 2 ... 10 times pickup value and I = 0.5 ... 2 In	±9% or ±40 ms (according to the selected curve, see <a href="#">↳ "12.2.2 Characteristics (IG&gt;, IG&gt;&gt;)"</a> )
Operate time	= Start time + Tripping delay

\*1) These start / pickup times are only valid under the following conditions:

- either: minimum current in 3 phases  $> 0.5 \cdot I_{n_{min}}$  for at least 0.5 s,
- or: externally supplied (only WIC1-4).

\*2) While being CT-supplied, the start times might be longer because the WIC1 has to collect enough electrical energy for a trip pulse.

\*3) if the protection stage is used together with [Inrush Blocking](#) it is necessary to set the tripping delay to at least 30 ms.

\*4) The calculated ground current values are released if there is at least  $0.25 \cdot I_{n_{min}}$  in all 3 phases or at least  $0.35 \cdot I_{n_{min}}$  in one phase, otherwise the value is assumed as 0.

**10.2.1.3 Unbalanced Load [46], Negative-Sequence Current Protection [51Q]**

Protection Stage I2>	Accuracy
Pickup value »I2« for I within 0.5 ... 2 In	±6% of the setting value or ±3% of the greatest phase current value.
Dropout Ratio	95%

Protection Stage I2/I1>	Accuracy
Pickup value »I2/I1« *5) for I within 0.5 ... 2 In	±2% (absolute)
Dropout Ratio	95%

Protection Stages I2/I1>, I2>	Accuracy
<b>Definite time</b> (»Char« = "DEFT")	
Tripping delay »t«	±1% or ±10 ms
Operate time (for »t« = 0 ms) at testing current ≥ 2 times pickup value	<70 ms *1) *2) *3)

Protection Stage I2>	Accuracy
<b>Inverse-Time / Characteristic curve</b>	
Start time (for »t« = 0 ms) at testing current ≥ 2 times pickup value	<70 ms *1) *2) *3)
Tripping delay For testing current in the range 2 ... 10 times pickup value	±6% or ±70 ms (according to the selected curve, see <a href="#">↳ "12.2.3 Characteristics »I2&gt;«"</a> )
Operate time	= Start time + Tripping delay

\*1) These start / pickup times are only valid under the following conditions:

- either: minimum current in 3 phases >  $0.5 \cdot I_{n_{min}}$  for at least 0.5 s,
- or: externally supplied (only WIC1-4).

\*2) While being CT-supplied, the start times might be longer because the WIC1 has to collect enough electrical energy for a trip pulse.

\*3) if the protection stage is used together with **Inrush Blocking** it is necessary to set the tripping delay to at least 30 ms.

\*5) The measuring value  $I_2/I_1$  is released under the conditions  $I_1 > 20\% I_n$  and  $I_2 > 0,5\% I_n$ , otherwise it is assumed as 0.

**10.2.1.4 Peak Overcurrent Protection**

Peak Overcurrent Protection $I_{peak}$ >	Accuracy
Pickup value »/«	$\pm 10\%$ of the setting value
Tripping delay »t«	$\pm 1\%$ or $\pm 10$ ms
Operate time (for »t« = 0 ms)	$< 20$ ms *1) *2)
at testing current $\geq 2$ times pickup value	15 ms typical

\*1) These start / pickup times are only valid under the following conditions:

- either: minimum current in 3 phases  $> 0.5 \cdot I_{nmin}$  for at least 0.5 s,
- or: externally supplied (only WIC1-4).

\*2) While being CT-supplied, the start times might be longer because the WIC1 has to collect enough electrical energy for a trip pulse.



### 10.2.1.5 Inrush Blocking

Inrush Blocking IH2	Accuracy
Pickup value $\gg IH2 / IH1 \ll$ *6) *7) for $I$ within the range $0.5 \dots 2 I_n$	$\pm 2\%$ absolute
Blocking of the Inrush Blocking based on a short-circuit current  Starting threshold $\gg I_{max} \ll$ *8)	$\pm 15\%$ of the setting value
Time limit of the blocking  Timer $\gg IH2 . t_{max} \ll$	$\pm 5\%$ or $\pm 30$ ms

\*6) The tripping delay must be at least 30 ms for all overcurrent stages that shall be stabilized by the Inrush Blocking.

\*7) The measuring value  $IH2 / IH1$  is released under the conditions  $IH1 > 0,3 I_n$  and  $IH2 > 0,03 I_n$ , otherwise it is assumed as 0.

\*8) If the limit current  $\gg I_{max} \ll$  is used then the threshold should be at least 15% below the current threshold of the protection stage that shall not be blocked in case of a short-circuit current.

### 10.2.1.6 Switch Onto Fault (SOTF)

The accuracy and tripping times depend on the protection function that triggers the SOTF.

In case of the smallest possible setting values and SOTF tripping delay  $\gg t \ll = 0$  ms, it is possible to reach the following accuracy for switching onto a 3-pole short-circuit when the WIC1 is self-powered:

Switch Onto Fault SOTF	Accuracy
Tripping delay $\gg t \ll$	$\pm 1\%$ or $\pm 10$ ms
Operate time (for $\gg t \ll = 0$ ms) at testing current $\geq 5$ times minimum pickup value  (including the duration of a WIC1 restart in self-powered mode)	$< 30$ ms  15 ms typical

### 10.2.1.7 Thermal Overload Protection

Thermal Overload Stage $ThR$	Accuracy
$K \cdot I_b$	$\pm 5\%$ of the setting value or $\pm 5\% I_n$ .
Tripping delay according to the equation in <a href="#">↪</a> “Tripping Time” in cold state (i. e. without previous warming)	$\pm 5\%$ of the calculated value or $\pm 1$ s.
Limiting error as multiple of assigned error	<ul style="list-style-type: none"> <li><math>I = 1.2 \dots 1.4 K \cdot I_b</math>: 2.0 (<math>\pm 10\%</math>)</li> <li><math>I = 1.4 \dots 1.6 K \cdot I_b</math>: 1.5 (<math>\pm 7,5\%</math>)</li> <li><math>I = 1.6 \dots 2.0 K \cdot I_b</math>: 1.0 (<math>\pm 5\%</math>)</li> </ul>

### 10.2.1.8 External Protection

External Protection $I_{peak}$ >	Accuracy
Tripping delay »t«	$\pm 1\%$ or $\pm 10$ ms
Operate time (for »t« = 0 ms)	<ul style="list-style-type: none"> <li>If externally supplied (WIC1-4), or if supplied via CTs with <math>I &gt; 0.5 I_n</math>: &lt;30 ms (typical 20 ms) in case of AC signaling &lt;20 ms (typical 8 ms) in case of DC signaling</li> <li>Triggered only <a href="#">via the Digital Input</a>, without any additional supply: &lt;500 ms (including the duration of a WIC1 restart in self-powered mode) *9)</li> </ul>

\*9) For a cold restart of a WIC1, the operate time is mainly characterized by the charging time of the capacitors for the trip pulse.

### 10.2.2 Measured Trip Times (fN = 50 Hz, 1-/3-phase)

Measurements for phase overcurrent:

- $I_n = I_{n,min}$
- Definite-time overcurrent (»Char« = "DEFT").
- Without additional trip delay (»I> . t« = 0).
- Measured from power off until trip impulse signal.
- Blue curve in the diagram below: 1 phase, 15 tests for each current value. Red curve: 3 phases, 5 tests for each current value.
- The setting »I« - labeled as  $I_{> . I}$  in the diagram below - varies in the range  $0.5I_n \dots 2.5I_n$ .

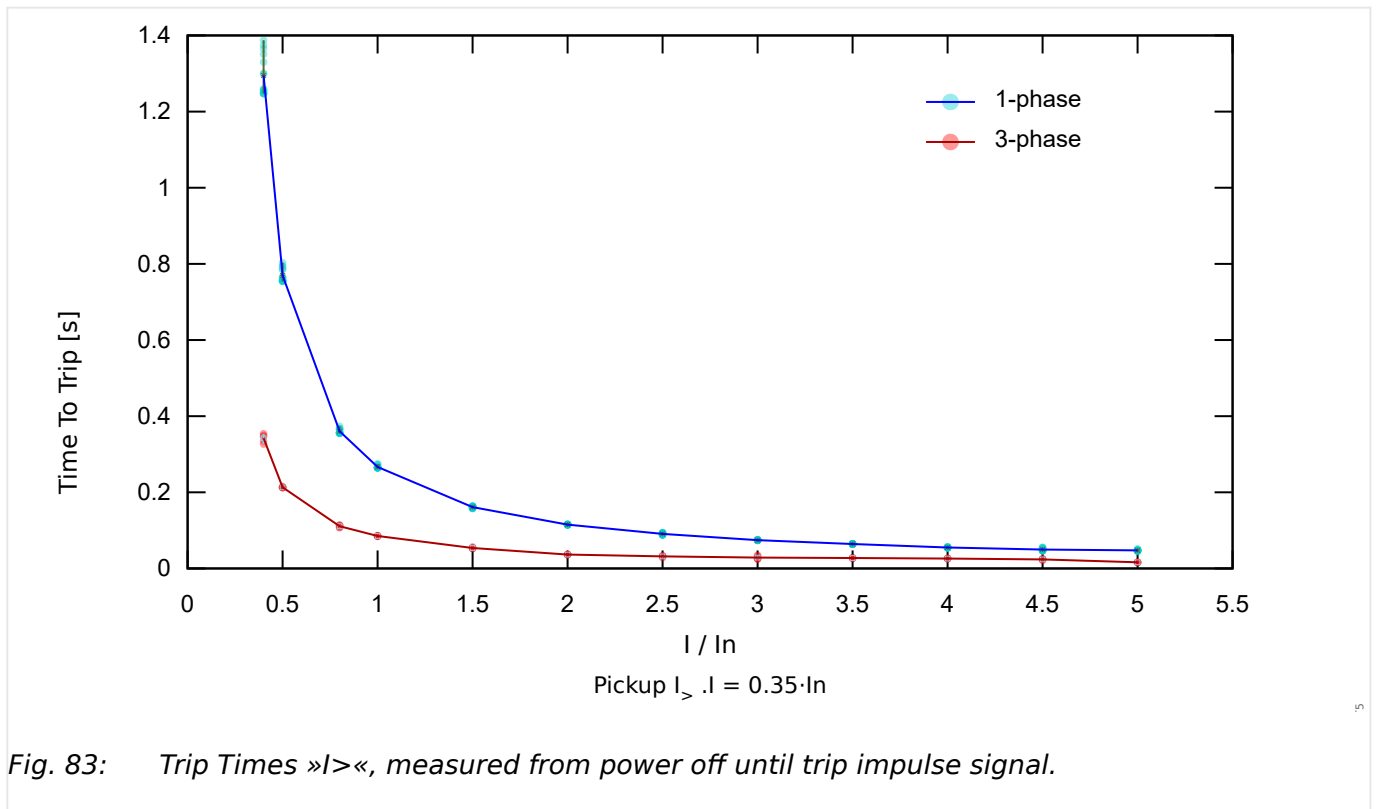

Fig. 83: Trip Times »I>«, measured from power off until trip impulse signal.

Pickup Setting I [In]	I [In]	Average Measured Trip Times [ms]	
		1-phase	3-phase
0.35	0.4	1295	342
	0.5	770	213
	0.8	360	111
	1.0	267	85
	1.5	161	54
	2.0	115	37
	2.5	90	32

## 10 Technical Data

### 10.2.2 Measured Trip Times (fN = 50 Hz, 1-/3-phase)

Pickup Setting I [In]	I [In]	Average Measured Trip Times [ms]	
		1-phase	3-phase
	3.0	74	29
	3.5	64	27
	4.0	55	26
	4.5	50	24
	5.0	48	16

## 10.3 Technical Data - DiggiMEC

### NOTICE!



Use copper conductors only, 75°C.  
Conductor size  $\leq$  AWG 14 [2.5 mm<sup>2</sup>].

### NOTICE!



Use an Ethernet cable CAT 3 (or better) with shielding for the connection between WIC1 and DiggiMEC. **Crossover cables must not be used!**

### 10.3.1 Climatic and Environmental Data

Storage Temperature:	-30°C to +80°C (-22°F to 176°F)
Operating Temperature:	-20°C to +60°C (-4°F to 140°F)
Permissible Humidity at Ann. Average:	<75% rel. (on 56 days up to 95% rel.)
Permissible Installation Altitude:	$\leq$ 2000 m (6561.67 ft) above sea level

### 10.3.2 Housing

Housing (Height / Width / Depth):	53 mm / 102 mm / 55,8 mm (see also dimension drawings in <a href="#">↪ "3.2.2 DiggiMEC Dimension Drawings"</a> )
Door cutout (Height / Width):	45 mm / 92 mm
Material, Housing:	Plastic
Weight:	<ul style="list-style-type: none"> <li>• DiggiMEC-A (without packaging): approx. 160 g</li> <li>• DiggiMEC-A (incl. packaging): approx. 300 g</li> <li>• DiggiMEC-B (without packaging): approx. 190 g</li> <li>• DiggiMEC-B (incl. packaging): approx. 330 g</li> </ul>

### 10.3.3 Degree of Protection EN 60529

Front panel with seal	IP52
Front panel without seal	IP50
Rear side terminals	IP20

### 10.3.4 Voltage Supply

#### **Supply via WIC1 CTs**

With the setting »Operation Preference« = “Early wake-up”:

- 1-phase wakeup =  $0.6 I_{n,min}$
- 3-phases wakeup =  $0.4 I_{n,min}$

With the setting »Operation Preference« = “Precise meas.”:

- 1-phase wakeup =  $1.1 I_{n,min}$
- 3-phases wakeup =  $0.75 I_{n,min}$

Since the setting »Operation Preference« = “Early wake-up” results in less accurate measurement values it is recommended in general to keep the default value “Precise meas.”.

### 10.3.5 Binary Output Relays

Continuous current, max. switching current:	1 A AC
Max. switching voltage:	250 VAC
Contact type:	1 or 3 bistable relays, depending on device type: <ul style="list-style-type: none"> <li>• DiggiMEC-A: <ul style="list-style-type: none"> <li>1 normally open (Form A) contact</li> </ul> </li> <li>• DiggiMEC-B: <ul style="list-style-type: none"> <li>1 changeover contact, 2 normally open (Form A) contacts</li> </ul> </li> </ul>
Terminals:	Screw-type terminals

## 10.3.6 Standards - DiggiMEC

### 10.3.6.1 Approvals

	
	
	UL File Nr.: E217753 cULuc Certification of WIC1 and DiggiMEC - UL508, E217753 - NRGU

### 10.3.6.2 Design Standards

Generic standards	<p>2014/35/EU (2014-02-26, on the harmonisation of the laws of the Member States relating to making available on the market of electrical equipment designed for use within certain voltage limits)</p> <p>2014/30/EU (2014-02-26, on the harmonisation of the laws of the Member States relating to electromagnetic compatibility)</p> <p>2011/65/EU (2011-06-08, on the restriction of the use of certain hazardous substances in electrical and electronic equipment, with the following allowed exemptions: 6(a), 6(a)-I, 6(c), 7(a), 7(c)-I)</p> <p>2015/863/EU (2015-03-31, amending Annex II to Directive 2011/65/EU of the European Parliament and of the council as regards the list of restricted substances)</p>
Product standards	<p>IEC 60255-1, 2009</p> <p>IEC 60255-26, 2013</p> <p>IEC 60255-27, 2013</p>



### 10.3.6.3 Electrical Tests

#### EMC Tests

##### **Electrical Discharge Immunity Test (ESD)**

IEC 60255-26 [03/14]	Air discharge	8 kV
DIN EN 61000-4-2 [12/09] class 3	Contact discharge	6 kV

##### **Fast Transient Disturbance Immunity Test (Burst)**

IEC 60255-26 [03/14]	Power supply, mains inputs	±4 kV, 2.5 kHz
DIN EN 61000-4-4 [04/13] class 4	Other in- and outputs	±2 kV, 5 kHz

##### **Interference immunity against 1 MHz burst disturbance tests**

IEC 60255-26 [03/14]	differential mode	2.5 kV, 1 MHz
DIN EN 61000-4-18 [09/20]	common mode	1 kV, 2 s

##### **Interference immunity against surge immunity test**

IEC 60255-26 [03/14]		4 kV / 2 kV
DIN EN 61000-4-5 [03/19]		

##### **Interference immunity against high-frequent electromagnetic fields**

IEC 60255-26 [03/14]		30 V/m
DIN EN 61000-4-3 [04/11]		

##### **Interference immunity against magnetic fields of energy based frequency**

IEC 60255-26 [03/14]	continuously	100 A/m
DIN EN 61000-4-8 [11/10]	3 s	1000 A/m

##### **Interference immunity against line conducted interference quantities induced by high-frequent fields**

IEC 60255-26 [03/14]		10 V/m
DIN EN 61000-4-6 [08/14]		

**Interference immunity against surge voltage**

IEC 60255-26 [03/14]	within a current circuit	1 kV
IEC 60255-27 [11/14]	current circuit to earth	5 kV

**Measuring of the radio interference voltage**

DIN EN 55011 [05/18]		Limit value class B
----------------------	--	---------------------

**Measuring of the radio interference radiation**

DIN EN 55011 [05/18]		Limit value class B
----------------------	--	---------------------

#### 10.3.6.4 Safety-Related Tests

Overvoltage category	IEC 60255-27 [11/14]	III
Pollution degree	IEC 60255-27 [11/14]	3
Protection class	IEC 60255-27 [11/14]	II
Test of withstand alternating voltage for 1 min	IEC 60255-27 [11/14]	4 kV / 1 kV
Test of lightning surge voltage 1.2/50 $\mu$ s, 0.5 J	IEC 60255-27 [11/14]	5 kV / 1 kV
Inflammability	IEC 60255-27 [11/14]	rated
Single Defect Condition	IEC 60255-27 [11/14]	rated

**10.3.6.5 Environmental Tests**

Vibration and continuous vibration test:	IEC 60255-27 [11/14]	0.5 / 1 gn
	DIN EN 60255-21-1 [05/96]	Class 2
Shock and continuous shock test:	IEC 60255-27 [11/14]	5 / 10 gn
	DIN EN 60255-21-2 [05/96]	Class 2

**Classification:**

IEC 60255-27 [11/14]	Climate category	20/060/10
DIN EN 60068-1 [09/15]		

**Test Ad: Kälte**

IEC 60255-27 [11/14]	Temperature	-20°C
DIN EN 60068-2-1 [01/08]	Period of stress	16 h

**Test Bd: Dry heat**

IEC 60255-27 [11/14]	Temperature	+60°C (140°F)
DIN EN 60068-2-2 [07/07]	Rel. humidity	<50%
	Period of stress	72 h

**Test Cab: Humid heat (constantly)**

IEC 60255-27 [11/14]	Temperature	+60°C (140°F)
IEC 60068-2-78 [02/14]	Rel. humidity	93%
	Period of stress	10 Tage

**Test Db: Humid heat (cyclic)**

IEC 60255-27 [11/14]	Temperature	+60°C (140°F)
IEC 60068-2-30 [06/06]	Rel. humidity	95%
	Cycles (12 + 12 hours)	2

## 10.4 Technical Data - WIC1 CTs

CT types and respective order codes: See [↳ “2.6.1.3 Order Form of the WIC1-Compatible Current Transformers”](#).

Dimensions: See [↳ “3.2.3 Dimension Drawings of the WIC1-Compatible Current Transformers”](#).

### 10.4.1 Technical Data - WIC1 CTs, Construction Type 1

<b>CT (Construction Type 1: WIC1-WE2AS1, WIC1-W2AS1, ... , WIC1-W6AS1)</b>	
Standard:	IEC 61869-2
Protection degree:	IP20
Insulation class:	E (120°C)
Accuracy class:	5P80 (WIC1-W2AS1: 10P80)
Nominal frequency:	50 Hz / 60 Hz
Rated short-time thermal current $I_{th}$ :	20 kA for 1 s, or 25 kA for 1 s
Ambient temperature:	-5°C to +40°C (23°F to 104°F)
Primary window suitable for cable:	max. ø 50 mm
Material:	PU, PA6.6
Secondary terminal:	6 mm <sup>2</sup> solid / 4 mm <sup>2</sup> stranded, screw connection
Test wiring rated current:	0.288 A

### 10.4.2 Technical Data - WIC1 CTs, Construction Type 2

<b>CT (Construction Type 2)</b>		<b>Transformer Ratio</b>	<b>Prim. Rated Current Range</b>	<b>Test wiring</b>
WE2	WIC1-CT2-5P:	16 A / 0.083 A (14.4 A / 0.075 A)	16 ... 56 A	1 A / 50 A
W2	WIC1-CT2-10P:	16 A / 0.083 A (14.4 A / 0.075 A)	16 ... 56 A	1 A / 50 A
W3	WIC1-CT3:	32 A / 0.083 A (28.8 A / 0.075 A)	32 ... 112 A	1 A / 100 A
W4	WIC1-CT4:	64 A / 0.083 A (57.6 A / 0.075 A)	64 ... 224 A	1 A / 200 A
W5	WIC1-CT5:	128 A / 0.083 A (115.2 A / 0.075 A)	128 ... 448 A	1 A / 400 A

<b>WIC1-CT2-5P, WIC1-CT2-10P, WIC1-CT3, WIC1-CT4, WIC1-CT5</b>	
Standards:	IEC 61869-1, IEC 61869-2. Fire resistance according to UL94 V-0
Insulation peak voltage:	0.72 / 3 / - kV
Insulation class:	E
Accuracy class:	5P80 (WIC1-CT2-10P: 10P80)

<b>WIC1-CT2-5P, WIC1-CT2-10P, WIC1-CT3, WIC1-CT4, WIC1-CT5</b>	
Nominal frequency:	50 Hz / 60 Hz
Rated continuous thermal current:	extd. 1000%
Rated short-time thermal current $I_{th}$ :	21 kA for 3 s, or 25 kA for 1 s
Peak current:	$I_{th} = 2.5 \cdot I_{th}$
Ambient temperature:	-40°C ... +85°C (-40°F ... 185°F)
Primary window suitable for cable:	max. $\varnothing$ 50 mm
Material:	Thermoplast housing filled with polyurethane resin. The housing is flame resistant and free from halogen.
Secondary terminal:	Screw connection, M3 screws for wires with section up to 4 mm <sup>2</sup>

<b>Measured Winding Resistance at 23°C (73°F)</b>		
WE2	WIC1-CT2-5P:	2.1 Ω
W2	WIC1-CT2-10P:	2.8 Ω
W3	WIC1-CT3:	4.1 Ω
W4	WIC1-CT4:	4.0 Ω
W5	WIC1-CT5:	7.9 Ω

**Maximum Cable Length for the WIC1 CTs**

The maximum allowed impedance of the cable connections (i. e. the sum for both contacts) between WIC1 and CT is **1.5 Ω**.

From this follows that for a usual copper cable with 0.5 mm<sup>2</sup> cross-section (and typical ambient temperatures) a maximum length of **22 meters** per cable is allowed.

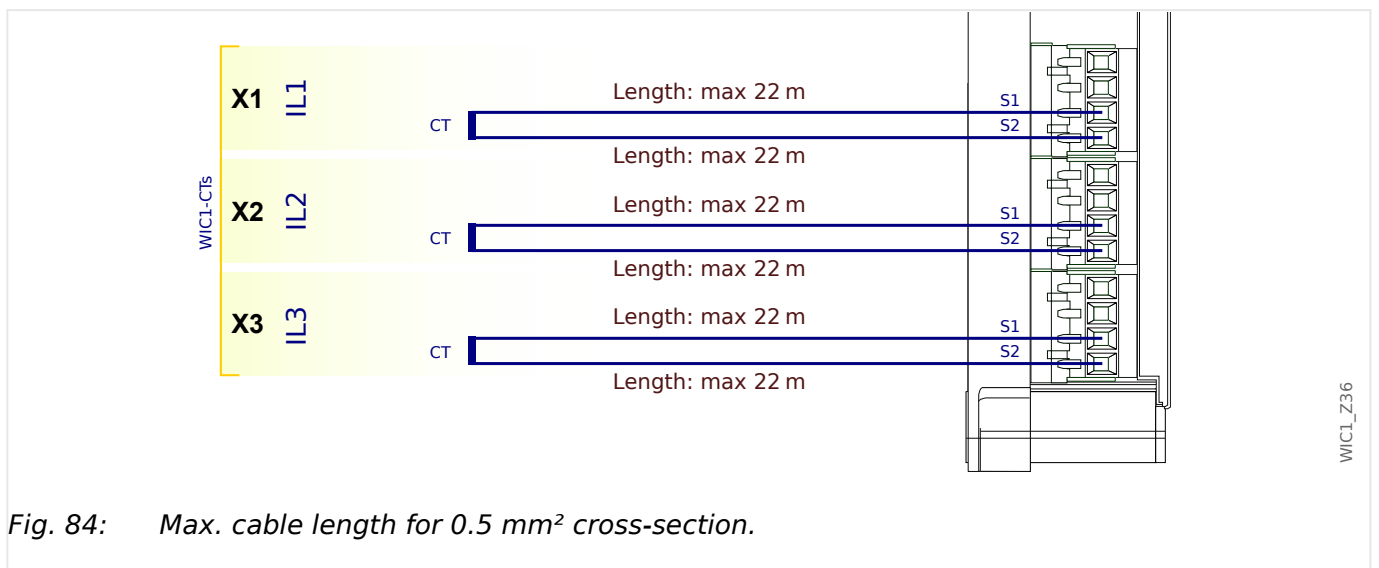

Fig. 84: Max. cable length for 0.5 mm<sup>2</sup> cross-section.

### 10.4.3 Technical Data – Adapter CTs for 1 A, 5 A

Adapter CTs (for 3 phases, combined in 1 housing)		Primary rated current	Secondary rated current
Adapter 1 A → WIC1	WIC1-CT-1A:	1 A	0.083 A
Adapter 5 A → WIC1	WIC1-CT-5A:	5 A	0.083 A

WIC1-CT-1A, WIC1-CT-5A	
Standard:	IEC 61869-1, IEC 61869-2
Rated insulation level:	0.72 / 3 / - kV
Insulation class:	E
Accuracy class:	5P80
Nominal frequency:	50 Hz / 60 Hz
Rated continuous thermal current:	extd. 120%
Rated short-time thermal current $I_{th}$ :	$I_{th} = 100 \cdot I_r / 1 \text{ s}$
Dynamic current:	$I_{dyn} = 2.5 \cdot I_{th}$
Ambient temperature:	-40°C ... +85°C
Material:	Thermoplast housing filled with polyurethane resin. The housing is flame resistant and free from halogen.
Connections:	2 cables (for input/primary and output/secondary current), length 3000 mm. (The cables may be shortened to fit the given application.)

**Maximum Cable Length:** The requirements for the Adapter CTs differ from those for the WIC1 CTs. See [↪ “12.3 Requirements for 1 A/5 A Standard CTs with WIC1 Adapter CTs”](#).

#### WARNING!



Due to technical constraints with respect to construction, the Adapter CT has a window, just like the feed-through of a standard CT. But it is not permitted to mount an MV / primary current cable through this Adapter CT window!

Ignoring this can result in dangerous voltages at the contacts, and due to wrong measuring values there would not be any effective protection of your equipment.

#### NOTICE!



Please note also these peculiarity, that are inherent to the construction of the Adapter CTs:

- The housing (see [↪ Fig. 15](#)) contains three Adapter CTs, so that all three phase currents are covered. Therefore you need to buy only one unit, see also [↪ “Adapter CTs for 1 A or 5 A”](#).
- There are no test windings. Therefore the test sockets of the WIC1 **cannot** be used with the Adapter CTs.

### 10.4.4 Test Windings, Test Sockets

The Adapter CTs do not feature any test winding, therefore these data are valid only for the WIC1 CTs (construction type 1 or 2).

CT Type	Prim. Current Range	Injected C-D Test Current	Induced Current
<b>W2, WE2</b>	16 ... 56 A	1 A	50 A
<b>W3</b>	32 ... 112 A	1 A	100 A
<b>W4</b>	64 ... 224 A	1 A	200 A
<b>W5</b>	128 ... 448 A	1 A	400 A
<b>W6</b>	256 ... 896 A	1 A	800 A

The test windings transfer only a limited current range in a reliably linear magnetic induction. There is a limit current, above which the induced secondary current does not increase any further. As a consequence, it is not possible to perform a secondary test using the test sockets if the pickup threshold is above this limit current.

These limit currents for the test sockets depend on the CT type. At SEG, the following values have been measured.

CT Type (see also <a href="#">↪ “WIC1 CTs”</a> , <a href="#">↪ “3.3.2 Selection of a WIC1-Compatible Current Transformer”</a> )	Maximum Test Current [In,min]	Maximum Test Current as Injected C-D Test Current [A]	Maximum Test Current as a Primary Value [A]
WE2 [16 - 56 A], Construction Type 1, WIC1-WE2AS1	17.5	5.6	280
W2 [16 - 56 A], Construction Type 1, WIC1-W2AS1	25	8.0	400
W3 [32 - 112 A], Construction Type 1, WIC1-W3AS1	17.5	5.6	560
W4 [64 - 224 A], Construction Type 1, WIC1-W4AS1	12.5	4	800
W5 [128 - 448 A], Construction Type 1, WIC1-W5AS1	4	1.28	512
WE2 [16 - 56 A], Construction Type 2, WIC1-CT2-5P	22.5	7.2	360
W2 [16 - 56 A], Construction Type 2, WIC1-CT2-10P	25	8.0	400
W3 [32 - 112 A], Construction Type 2, WIC1-CT3	20	6.4	640
W4 [64 - 224 A], Construction Type 2, WIC1-CT4	20	6.4	1280
W5 [128 - 448 A], Construction Type 2, WIC1-CT5	10	3.2	1280



## 10.5 Technical Data - WI1SZ4

Coil voltage: 24 V DC  $\pm$  10%

- The WI1SZ4 can be set electrically.
- The WI1SZ4 can be reset mechanically.

Cable Color	Diameter	Function
black	0.25mm <sup>2</sup>	Ground / Set

Table 1: Coil connection

Maximum cable connection length: 1 m

## 10.6 Technical Data - WI1SZ5

Coil voltage: 24 V DC  $\pm$  10%

Contact Rating:

- 230 V AC / 3 A
- 230 V DC / 0.12 A
- 115 V DC / 0.2 A
- 24 V DC / 2 A
- The WI1SZ5 has two potential-free changeover contacts.
- The WI1SZ5 can be set and reset electrically.

The WI1SZ5 can be reset mechanically.

	Cable Color	Diameter	Function
Coil connection	brown	0.25mm <sup>2</sup>	(-) Ground
	violet	0.25mm <sup>2</sup>	(+) Set
	orange	0.25mm <sup>2</sup>	(+) Reset
Changeover contact 1	black	0.5mm <sup>2</sup>	NO contact
	blue	0.5mm <sup>2</sup>	changeover contact
	red	0.5mm <sup>2</sup>	NC contact
Changeover contact 2	white	0.5mm <sup>2</sup>	NO contact
	yellow	0.5mm <sup>2</sup>	changeover contact
	green	0.5mm <sup>2</sup>	NC contact

“NO”: normally open. “NC”: normally closed.

Maximum cable connection length: 1 m

# 11 Troubleshooting

## 11.1 In Case You Need to Contact Our Service-Team

Our service-team will need detailed information depending on the type of problem. If possible, we ask you kindly to have the following information ready; this will speed up our analysis of your problem.

We always need the following data:

- A detailed description of the problem.
- The serial number of the device, either from the type label, or from here: [Device Para / Version] »S/N«
- The build number of the firmware, either from the type label (if still up to date), or from here: [Device Para / Version] »Build«
- If the device has issued an error message our service-team needs to know the message text / type and the displayed "Value". (For example: Self-Supervision Message "SE1" with Value = 24307.)

The Self-Supervision Messages can be checked here: [Operation / Self-Supervision / Messages]

Depending on the type of the problem the following might also be useful for analysis:

- The settings file. (Transfer all settings into Smart view and save as a file in format \*.WiPara.)

## 11.2 Self-Supervision Messages

The protection device supervises its normal operation by executing various self-supervision checks during runtime of the device.

Please check the self-supervision messages under [Operation / Self-Supervision / Messages].



Hint: You can assign the event, that a new error or warning message occurs, to a DiggiMEC LED. This way you can see immediately if something noteworthy has happened:

- [Device Para / DiggiMEC / LEDs] »*LEDx assign.*« = "Sys . New error/warning", see also [↪ "3.9.1.2 LED Configuration \(DiggiMEC\)"](#).
- [Device Para / DiggiMEC / LEDs] »*LEDx latching*« = "With latching" (or = "Latch. w. Auto-Reset"), see also [↪ "3.9.1.3 Latching of the DiggiMEC LEDs"](#).

**Note:** A device with a firmware labeled as "Prototype" (e. g. a specimen for trade fairs) has the following special behavior: If the Self-Supervision of the protection device has detected a (device-internal) error (as listed in [↪ "11.2.1 Self-Supervision - Error Messages"](#)), the WIC1 System-ERROR-LED starts flashing red (in addition to the message that is recorded in the internal memory). The flashing can be reset via the direct command [Operation / Reset] »Sys . Rst. Err. LED«.

## 11.2.1 Self-Supervision - Error Messages

Description	Information	Corrective Action
<b>SE 1</b> Abort	<i>The WIC1 underwent an unscheduled restart.</i>	Get in contact with our service-team. We recommend having the information listed in <a href="#">↳ "11.1 In Case You Need to Contact Our Service-Team"</a> ready. In case of an error <b>SE 1</b> , in particular the displayed "Value" is needed for further analysis.  Depending on the type of problem, you will either be told how to fix the problem, or - if further device-internal data is needed - you will be supplied with a tool for error analysis.
<b>SE 2...5</b> Problem w. resources	<i>Critical level of WIC1-internal resources. It is not possible for the user to take any actions.</i>	Get in contact with our service-team.  You will be supplied with a tool for error analysis.
<b>SE 18</b> Back-up Prot	<i>The WIC1 has unexpectedly launched the Backup Protection.</i>	Get in contact with our service-team.
<b>SE 19...23</b> DiggiMEC Problem w. resources	<i>Critical level of DiggiMEC-internal resources. It is not possible for the user to take any actions.</i>	Get in contact with our service-team.
<b>SE 24</b> DiggiMEC Abort	<i>The DiggiMEC underwent an unscheduled restart.</i>	Get in contact with our service-team.

## 11.2.2 Self-Supervision - Warning Messages

Description	Information	Corrective Action
<b>SW 1</b> <i>SSV Idx Overflow</i>	<i>There have been so many Self-Supervision messages (more than 65535) that the running number underwent an overflow.</i>	You might want to check all the listed messages for the potential reason of this excessive number of messages.
<b>SW 2</b> <i>Run Mode</i>		<p>The displayed "Value" specifies whether the WIC1 is running in normal mode (Value = 1, full functionality) or in protection-only mode (Value = 2).</p> <p>After two device-internal errors within a short time, the WIC1 enters a protection-only mode. In this mode, all communication functionality (including connections to Smart view) is unavailable.</p> <p>(See also the signaling via LEDs, <a href="#">↪ "The »System« LED(s) - "Ready", "Error"").</a></p> <p>You can try to leave the protection-only mode (and re-enter normal mode) by a cold restart of the WIC1.</p>
<b>SW 3</b> <i>V Superv.</i>	<i>A problem with the internal power supply of the WIC1 has been detected. This may affect the capability of the device to operate a trip coil and outputs.</i>	<p>A further safe operation of the WIC1 can be assumed only if you check the WIC1, proceeding as follows:</p> <p>WIC1-4 with external power:</p> <ul style="list-style-type: none"> <li>• 1. ▷ Make sure the supplied voltage (and power) is sufficient.</li> <li>• 2. ▷ Restart the WIC1-4, executing the Direct Command [Service / General] »Sys . User Restart«.</li> <li>• 3. ▷ Wait for 5 minutes.</li> <li>• 4. ▷ Check whether this warning message has been issued again, and check that the Ready/System LED is lit in green color.</li> </ul> <p>Self-powered WIC1:</p> <ul style="list-style-type: none"> <li>• 1. ▷ Verify that there is no phase current flow (nor any supply via USB), so that the WIC1 is off.</li> <li>• 2. ▷ Feed in a phase current &gt; 0.5 I<sub>nmin</sub> in all 3 phases.</li> <li>• 3. ▷ Wait for 5 minutes.</li> <li>• 4. ▷ (Re-)connect a DiggiMEC. Check whether this warning message has been issued again, and check that the Ready/System LED is lit in green color.</li> </ul> <p>In addition to the checks mentioned above (i. e. re-issue of the warning message, Ready/System LED), you should also check the outputs: Is it possible that the assigned signals rattle (e. g. a ground overcurrent pickup with a low pickup threshold)?</p> <p>It is also advisable to check the connection cable between WIC1 and</p>

Description	Information	Corrective Action
		<p>DiggiMEC (if there is one). (See also the related message in <a href="#">↳ Chapter 3.10.</a>)</p> <p>If the problem still persists after all these potential problems have been checked/ fixed get in contact with our service-team.</p>
<b>SW 4</b> <i>V Superv. FI</i>	<p><i>A wrong configuration or usage of the output seems to have caused a problem with the internal power supply of the WIC1. This may affect the capability of the device to operate a trip coil and outputs.</i></p>	<p>For a WIC1-4: The setting »Prot . Out. assign.« = "Prot . Syst. OK. &amp; Ext.Suppl." is not allowed with the setting »Prot . Out. Mode« = "Impulse Output". Change the configuration. Then perform a restart and all the checks described for <a href="#">warning SW 3.</a></p> <p>(More information about the use of the setting »Prot . Out. Mode« can be found in <a href="#">↳ "3.8.1 Self-Supervision Contact for the WIC1-4"</a>.)</p> <p>For a WIC1-1, WIC1-2 or WIC1-3: Follow the description for warning message <a href="#">SW 3.</a></p>
<b>SW 5</b> <i>Modbus TX-stall</i>	<p><i>There was an internal problem with Modbus communication. The communication channel has been reset and restarted.</i></p>	<p>If the problem occurs often then get in contact with our service-team.</p>

### 11.2.3 Self-Supervision - Information Messages

Description	Information	Corrective Action
<b>SI 1</b> <i>Firmware Update</i>	<i>Information that a new device firmware has been installed on the WIC1. The displayed "Value" is the new Build number after the update.</i>	
<b>SI 2</b> <i>Device restart</i>	<i>Information that the WIC1 has been restarted.</i>	<p>The displayed "Value" shows the reason for the device restart. See the table in <a href="#">↪ "7.1 Device Start (Reboot)"</a>.</p> <p>However, the restart reasons number 1 and 6 are intentionally omitted, i. e. get never listed as <b>SI 2</b> messages.</p>
<b>SI 3</b> <i>Settings changed</i>	<i>Information that the settings (e.g. the protection parameters) have been modified.</i>	<p>The message value is a counter value. Each change of the settings – independent of the number of changed parameters – increases this counter by 1.</p> <p>This is also true of settings that are made via DIP/HEX switches.</p>
<b>SI 4</b> <i>DiggiMEC Restart Reason</i>	<i>Information that the DiggiMEC has been restarted.</i>	<p>The displayed "Value" shows the reason for the device restart. See the table in <a href="#">↪ "7.1 Device Start (Reboot)"</a>.</p> <p>However, the restart reasons number 1 and 6 are intentionally omitted, i. e. get never listed as <b>SI 4</b> messages.</p>
<b>SI 5</b> <i>DiggiMEC HMI Issue</i>	<i>Information about communication problems between WIC1 and the DiggiMEC HMI.</i>	<p>The message value is a counter value. Each failure of data transfer between WIC1 and DiggiMEC increases this counter by 1.</p> <p>Note that the flag indicators / output relays are not affected.</p>
<b>SI 6</b> <i>Password changed</i>	<i>Information that the password has been changed by the user.</i>	The message value is the number of password changes that have been made within some time.
<b>SI 7</b> <i>Invalid password</i>	<i>Information that a wrong password was entered.</i>	The message value is the number of wrong passwords that have been entered within some time.



### 11.3 Signals via LEDs (at WIC1 or DiggiMEC)

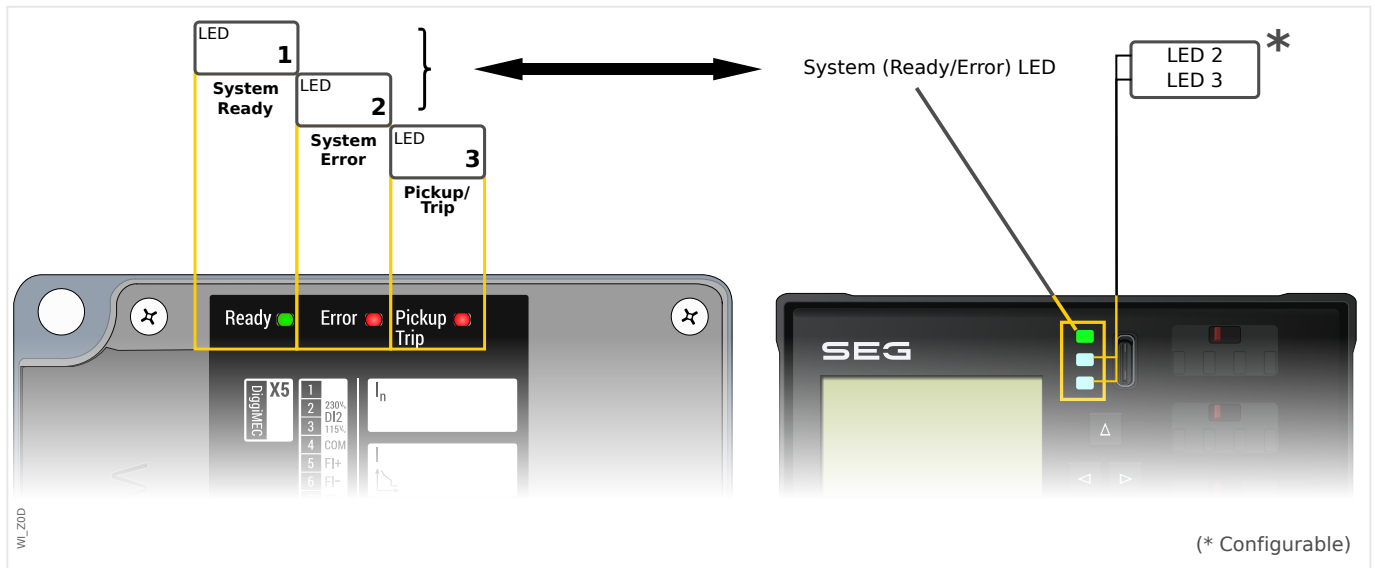

**i** The WIC1 features one green “READY” LED and a red “ERROR” LED. These two show the WIC1 overall health, so that they function as a “System LED”.

The DiggiMEC features three two-colored (red/green) LEDs, and the first LED corresponds to the “System LED”, as it (also) shows the WIC1 overall health.

#### System-LED is Off (Not Illuminated)

Description	Information	Corrective Action
The WIC1 <b>System-READY-LED is off</b> (not illuminated), and (if a DiggiMEC is connected) the DiggiMEC System LED is also off.	The WIC1 is not ready (yet). Either it is still starting up, or there is no sufficient power supply (via the CTs).	If the WIC1 is still starting up wait for a while. The System LED is illuminated green only after all protection functions have become active and there is enough power for a trip pulse.  Otherwise, please check the connected current inputs (and/or the supply voltage in case of a dual-powered variant). If it is OK, send the device back to SEG to be repaired.
	WIC1 and/or DiggiMEC have been started into the “Service Mode” (by pressing the »RESET« key during start-up).	This is not an error: This mode allows for resetting all parameters to the factory defaults, or you can install a firmware update. The DiggiMEC display should be working, and the displayed messages guide you through the available resetting or updating options.  Afterwards, you can simply leave the “Service Mode” by another restart (of the DiggiMEC).
The <b>DiggiMEC System LED is off</b> (not illuminated), and the DiggiMEC display is also off.	The DiggiMEC is not supplied with electricity, neither from the WIC1, nor via the USB interface from a connected PC.	Check the connection to the WIC1. If the problem persists try to connect a PC to the DiggiMEC USB interface. (Note that the DiggiMEC is not usable without WIC1.)
The <b>DiggiMEC System LED is off</b> (not illuminated), but the DiggiMEC display is working.	The DiggiMEC is properly connected to the WIC1, but the	If the WIC1 is still starting up wait for a while. The System LED is illuminated green only after all protection functions

Description	Information	Corrective Action
	<p>WIC1 reports that protection or tripping is <b>not</b> available.</p>	<p>have become active and there is enough power for a trip pulse.</p> <p>Otherwise, please check the connected current inputs (and/or the supply voltage in case of a dual-powered variant). Note that the supply via the DiggiMEC USB interface is sufficient for starting both WIC1 and DiggiMEC, but is <b>not</b> sufficient for enabling the WIC1 to issue a trip pulse. (The reason for this is that the pulse output needs to deliver 24 Volts, see <a href="#">↳ “10.1.8.1 Impulse Output for the Tripping Coil”</a>, but USB supplies only 5 Volts.)</p> <p>Furthermore, check the WIC1 and its LEDs, check the System Recorder for recent entries. If it turns out that the WIC1 is defective send it back to SEG to be repaired.</p>

**System-READY-LED is Lit Constantly Green**

Description	Information	Corrective Action
<p>The WIC1 <b>“READY” LED is constantly green</b> (and the same for the DiggiMEC System LED).</p>	<p>This is not a device error. The WIC1 is ready for operation and protects your electrical equipment, all protection functions have become active, and enough energy for a trip pulse has been stored. If you have the impression that the relay is not working correctly or you have any problems with setting the parameters, please check the next troubleshooting entries.</p>	<p>—</p>
<p>The WIC1 <b>“READY” LED is constantly green</b>, and the same for the DiggiMEC System LED, but the display shows: <b>“Level 2 - Smart view only”</b></p>	<p>The WIC1 is ready for operation and protects your electrical equipment, all protection functions have become active, and enough energy for a trip pulse has been stored. The DiggiMEC, however, can be used only as a communication proxy between WIC1 and a Windows-PC.</p>	<p>The firmware of the WIC1 has become incompatible to the DiggiMEC after an upgrade. (Fact is that the whole menu and parameter structure of the WIC1 must also be stored within the DiggiMEC.)</p> <p>You can still connect a Windows-PC (with an installed <i>Smart view</i>) to the DiggiMEC, so that you can operate the WIC1 as usual, via <i>Smart view</i>. But the DiggiMEC will be re-enabled to show values and settings only by bringing WIC1 and DiggiMEC to the same firmware version again. This can be done by installing the latest firmware upgrades onto WIC1 and/or DiggiMEC.</p>

**System-LED is Flashing Red**

Description	Information	Corrective Action
<p>The <b>DiggiMEC System LED is flashing red ↔ green</b>. The DiggiMEC display shows: <b>“Level 1 - WIC1 stopped HMI support”</b></p>	<p>The WIC1 has probably done an automatic restart (due to previous device-internal errors) and entered the “Protection-Only” operating mode.</p>	<p>In this mode, only the protection and supervision functions have been started. (This might hopefully reduce the risk of another error.) Although the protection functionality is fully active it is recommended to check (and/or replace) the WIC1. Contact the SEG Support.</p>

### System-(ERROR-)LED is Lit Constantly Red

Description	Information	Corrective Action
The WIC1 "Error" LED is constantly red.	The (hardware-based) backup protection is up and running, but the WIC1 could not start as normal due to a serious software or hardware error.	The backup protection has become active automatically, so that there is at least some basic protection. Nevertheless, the WIC1 needs to be checked as soon as possible. Try a restart, and/or contact SEG Support.
The DiggiMEC System LED is constantly red. The DiggiMEC display shows: "Level 0 - No communication to WIC1"	This is only possible if the DiggiMEC is supplied with electricity via the USB interface from a connected PC, but there is no connection to the WIC1.	<p>Check the connection between DiggiMEC and WIC1.</p> <p>Check whether the WIC1 is running in the "Backup Protection" mode, see <a href="#">↪</a>. (For information about the "Backup Protection", see <a href="#">↪</a> "5.14 Integrated Backup Phase Overcurrent Protection".)</p> <p>Check whether the WIC1 is defective.</p> <p>If everything turns out to be o.k. contact the SEG Support.</p>

## 11.4 Problems with the Device

### 11.4.1 Hardware

Description	Information	Corrective Action
Supply via <b>Powerbank</b> is not possible.	The so-called powerbanks are constructed with respect to charging batteries, and many of them cannot be used as a permanent power supply.	<p>It is possible to supply the WIC1 with connected DiggiMEC by a PC, via the USB interface. This way it is possible to make settings without the supply via the CTs. (But keep in mind that the USB voltage of 5 Volt is not sufficient for the trip coil output or the flag indicators / output relays.)</p> <p>But this kind of supply via USB is not possible, if a powerbank is connected, instead of a PC. This is due to the design of a powerbank and cannot be solved by any means related to the DiggiMEC or WIC1!</p> <p>There are powerbank models with a key for power-on/wake-up/testing; these models output the USB voltage only after the key has been pressed.</p> <p>Independent of this, many powerbank models feature a device-internal automatic switch-off. As soon as the current flow drops below a particular value (typical 100 mA) the powerbank switches the voltage off. The reason is that the risk of overcharging a battery shall be minimized. But since DiggiMEC and WIC1 are designed for very low power consumption they use much less than 100 mA, and this fact makes such types of powerbanks unusable as a power supply of DiggiMEC und WIC1.</p>
Wrong measuring and tripping values.	Wrong wiring	Verify that the wiring of the <a href="#">contacts S1, S2</a> and of the <a href="#">test windings C, D</a> is

Description	Information	Corrective Action
		correct. Check the phase sequence and phase angle.
	<i>Test winding short-circuited.</i>	Make sure that the secondary side of a test winding is always – except when the relays is tested – operated openly.
	<i>Grounding of a winding terminal of the measuring winding.</i>	No winding terminal of the measuring winding must be grounded! Grounding is done internally and connected with terminal “PE”, see <a href="#">↪ “3.3.1 Grounding”</a> .
<b>Low-energy tripping coil does not trip.</b>	<i>The coil polarized with permanent magnet has been connected to TC+ und TC– with the wrong polarity.</i>	Check the wiring.
<b>Failure of a binary output</b> (DiggiMEC).	<i>The physical status does not match the reported state, as it is being shown via Smart view.</i>	Check the following issues: <ul style="list-style-type: none"> <li>• Is the binary output in latched state? (»BOx latching« = „With latching“)?</li> <li>• Try to reset the output, e. g. via the Direct Command [Operation / Reset] »Rst. LEDs, Fls«.</li> <li>• Check the wiring.</li> <li>• See also the entry <a href="#">Binary outputs do not react</a>.</li> <li>• If all these checks do not yield any results, send the device back to the manufacturer.</li> </ul>
<b>Failure of a binary input</b> (WIC1).	<i>The physical status does not match the reported state, as it is being shown via Smart view.</i>	Check the following issues: <ul style="list-style-type: none"> <li>• Check the typecode of the WIC1 – Does this device variant feature configurable Digital Inputs?</li> <li>• Is the voltage level set correctly? Check the setting at [Device Para / WIC1 / Digital Inputs] »Nom voltage«.</li> <li>• Is the voltage level of the digital input (i. e. the signal level) correct?</li> <li>• Check the wiring.</li> <li>• If all these checks do not yield any results, send the device back to the manufacturer.</li> </ul>
<b>No system time</b> is shown via Smart view.	<i>This is not an error, as the WIC1 does not feature a real-time clock.</i>	All timestamps, as shown e. g. in the Fault Recorder, refer to the device uptime, i. e. this is the time since the last reboot.

## 11.4.2 Operation of the Device

Description	Information	Corrective Action
<p>The <b>binary outputs or LEDs are in unexpected state.</b></p>	<p>A binary output or an LED has been reconfigured from latched to unlatched.</p>	<p>Try to reset the WIC1, e. g. via the Direct Command [Operation / Reset] »Rst. LEDs, Fls«.</p> <p>Independent of this, note that the set value of »t-Off Delay« has to elapse before the binary outputs / LEDs will change their state.</p> <p>Moreover, note that a latched state even »survives« a restart of the device.</p>
<p>Smart view is set to the <b>wrong language (e. g. English).</b></p>	<p>You have installed Smart view with English language. Now you want to switch to a different language.</p>	<p>Select [Settings / Language] within Smart view and select your desired language. A window will pop up. This informs you that the language will get activated after a restart of Smart view. Accept this information, close and restart Smart view.</p>

### 11.4.3 Parameter Settings

Description	Information	Corrective Action
<p><b>All settings are locked</b> against changes in Smart view.</p>	<p><i>This is probably not an error, but due to the parameter setting [Device planning / WIC1 + DiggiMEC] »Prot . Settings valid« = "Switches".</i></p>	<p>Set »Prot . Settings valid« = "Software" to enable a configuration via DiggiMEC and/or Smart view.</p> <p>(Be aware, however, that DIP/Hex switches are ignored by then. See also <a href="#">↳ "Validity of the DIP-/HEX-Switches".</a>)</p>
<p><b>Settings via DIP/HEX switches are not possible anymore.</b></p>	<p><i>This is probably not an error, but due to the parameter setting [Device planning / WIC1 + DiggiMEC] »Prot . Settings valid« = "Software".</i></p>	<p>The DIP/HEX switches are taken into account again only after a reset to factory defaults. This is achieved by the direct command [Service / General] »Factory Reset«.</p> <p>(See also <a href="#">↳ "2.13 Reset to Factory Defaults".</a>)</p>

## 11.4.4 Protection and Control

Description	Information	Corrective Action
<b>Problem with current measurement.</b>	<i>The measured values of current show a big fluctuation.</i>	Adjust [Field Para / General Settings] »f« to the connected grid frequency (50 Hz or 60 Hz).
<b>Binary outputs do not react.</b>	<i>The contacts of the binary outputs do not open or close. This can be checked by simulating a fault and checking the binary output contacts with measurement equipment.</i>	<p>Check the following issues:</p> <ul style="list-style-type: none"> <li>• Has the DiggiMEC been correctly set within the WIC1 settings? (Check menu branches [Device planning / WIC1 + DiggiMEC] and [Device Para / DiggiMEC].)</li> <li>• Acknowledge the binary outputs, if applicable.</li> <li>• Is the status of the binary output forced to a dedicated value? (The binary output can be overwritten for commissioning purpose, see menu branch [Service / Test (Prot inhibit)].)</li> <li>• Is the required protection function active?</li> <li>• Is overall protection active?</li> <li>• Are the field parameters set correctly (CT ratio etc.)?</li> <li>• Are the protection parameters set correctly (trip value, trip time)?</li> <li>• Is the assigned protection function blocked?</li> <li>• Is the wiring correct?</li> </ul>

### 11.4.5 Communication

Description	Information	Corrective Action
<p>The DiggiMEC is correctly connected to a PC, but the <b>USB COM port is not visible</b> on the PC.</p>	<p>The USB port (e. g. COM 5) is not visible in Smart view.</p>	<p>Open the <i>Device Manager</i> of the Windows PC, and check the entries below “Connections (COM &amp; LPT)”.</p> <ul style="list-style-type: none"> <li>If the DiggiMEC is listed as a generic “Serial USB Device (COM n)” [Windows 10], or as an “Unknown Device” [Windows 7] then the USB driver has not been properly installed during the installation of <i>Smart view</i>.</li> </ul> <p>(Re-)Install the USB driver that comes with the <i>Smart view</i> setup. (Driver installations require Administrator privileges.)</p> <p>A PC-DiggiMEC-WIC1 connection must be listed as “WI Line DiggiMEC USB (COM n)” in the <i>Device Manager</i>.</p>
	<p>It is not possible to connect Smart view to the DiggiMEC via USB. The corresponding USB port (e. g. COM 5) is not visible in the application.</p>	<p>Check the following issues:</p> <ul style="list-style-type: none"> <li><i>Smart view</i>: Is a sufficiently up-to-date version installed (4.90 or higher)?</li> <li>Plug off the USB cable from the protective device and plug it in again. After 10 seconds try again to connect <i>Smart view</i> to the relay.</li> <li>Restart your PC.</li> </ul>
<p>The <b>USB COM port is visible, but no connection</b> is possible.</p>	<p>It is not possible to communicate with Smart view to the WIC1 (via DiggiMEC and) via USB. The corresponding USB port (e. g. COM 5) is available and has been selected correctly.</p>	<p>Check the following issues:</p> <ul style="list-style-type: none"> <li>Are the DiggiMEC and the WIC1 started up completely and connected with each other)?</li> <li>Is the USB port of the PC still occupied by another application (or program)? Close those applications.</li> <li>Have special applications for communication analysis been installed on the PC? (In very rare cases it has been observed that some so-called “sniffers” – applications that monitor or log the serial communication messages – interfere with or even prevent the USB connection with the protective device.)</li> </ul>
	<p>The corresponding USB port (e. g. COM 5) is available and has been selected correctly, but the Windows operating system reports an “Error 720” as soon as Smart view tries to talk to the DiggiMEC over USB.</p>	<p>The communication between <i>Smart view</i> and DiggiMEC uses the IPv4 internet protocol, wrapped into a PPP (“Point-to-Point Protocol”) serial connection.</p> <p>Therefore make sure that your Windows PC supports the IPv4 internet protocol. (The connection is not possible if only IPv6 is available on the Windows PC.)</p>
<p>Smart view <b>cannot connect to the DiggiMEC / WIC1</b> although this has been possible before using the same PC.</p>	<p>A connection between Smart view and DiggiMEC / WIC1 has been possible before using the same PC. Now it is no longer possible to connect to the device.</p>	<p>Check the following issues:</p> <ul style="list-style-type: none"> <li>Are the connection settings of <i>Smart view</i> correct? (Check</li> </ul>



Description	Information	Corrective Action
		<p>at menu [Settings / Device Connection...].)</p> <ul style="list-style-type: none"> <li>• Check the wiring between PC and device.</li> <li>• Wait for 15 minutes and then try again to connect to the device.</li> <li>• Restart your PC and then try again to connect to the device.</li> </ul>
<p><b>No communication (data transfer)</b> <i>with Smart view possible, even though a connection has been established.</i></p>	<p><i>Required TCP/IP ports are not available.</i></p>	<p>Make sure that all TCP/IP ports in the range 52152 ... 52164 are available. They must neither be blocked by a firewall nor be used by any other software.</p>

## 12 Appendix

### 12.1 Appendix - Settings via DIP / HEX Switches

#### 12.1.1 Settings via DIP Switches (WIC1-2)

For the WIC1-2, the following settings can be made directly at the device, using the built-in switches:

- Setting of the Rated CT current, see [↪ “12.1.3 Setting of the Rated CT current In”](#).
- Setting of Characteristic, Pickup Current and Tripping Time / Characteristic Time of Phase Overcurrent Protection, stages I> and I>>, see [↪ “5.3.2 Phase Overcurrent Protection - Settings”](#).
- Setting of the Characteristic, Pickup Current and Tripping Time / Characteristic Time of the Earth (Ground) Overcurrent Protection, stage IG>, see [↪ “5.5.2 Earth \(Ground\) Overcurrent Protection - Settings”](#).
- Setting of the harmonics ratio and maximum current for the Inrush Protection, see [↪ “5.4 IH2 - Inrush Blocking”](#).
- Setting of the Pickup Current and Supervision Mode for the Peak Overcurrent Protection, see [↪ “5.9 Ipeak> - Peak Overcurrent Protection”](#).

The upper four DIP switch blocks are compatible with the four DIP switch blocks of the first WIC1 version (except for the additional overcurrent characteristics).

Although the enhanced protection functionality has made us increase the number of DIP switches with this second WIC1 version, however, the total number of DIP switches is obviously limited by the size of the housing. Therefore some settings cannot be set via a switch. These settings can be set only via DigiMEC or via Smart view. However, SEG has selected the meanings of the switches with great care, so that the usual settings for typical applications should be covered.

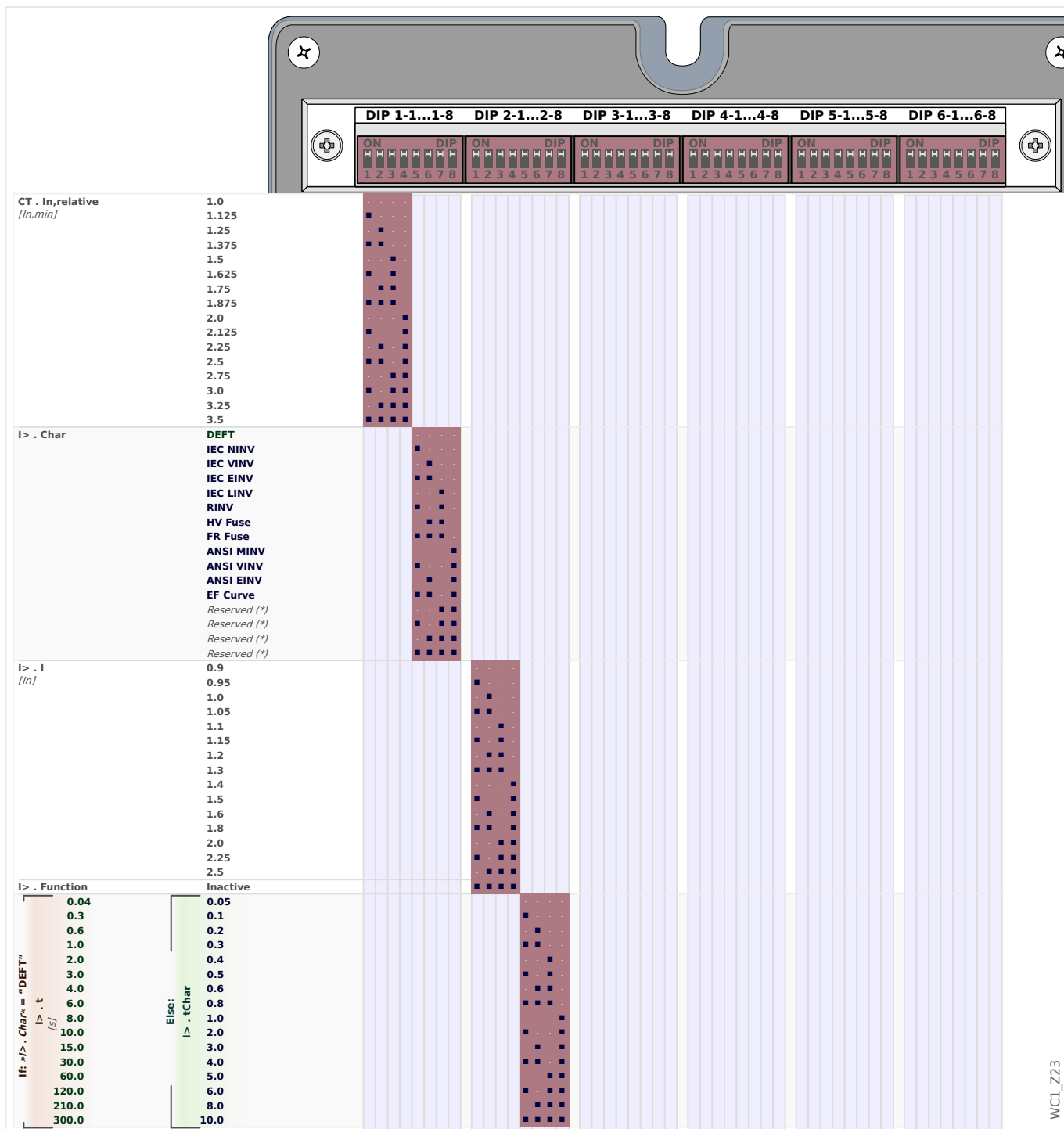

WIC1\_Z23

Fig. 85: Overview of the DIP switches for WIC1-2, part 1. (black "■" = ON, white "." = OFF)

(\*) This switch setting is assigned to the DEFT characteristic but reserved for additional characteristics to be added with future WIC1 versions.

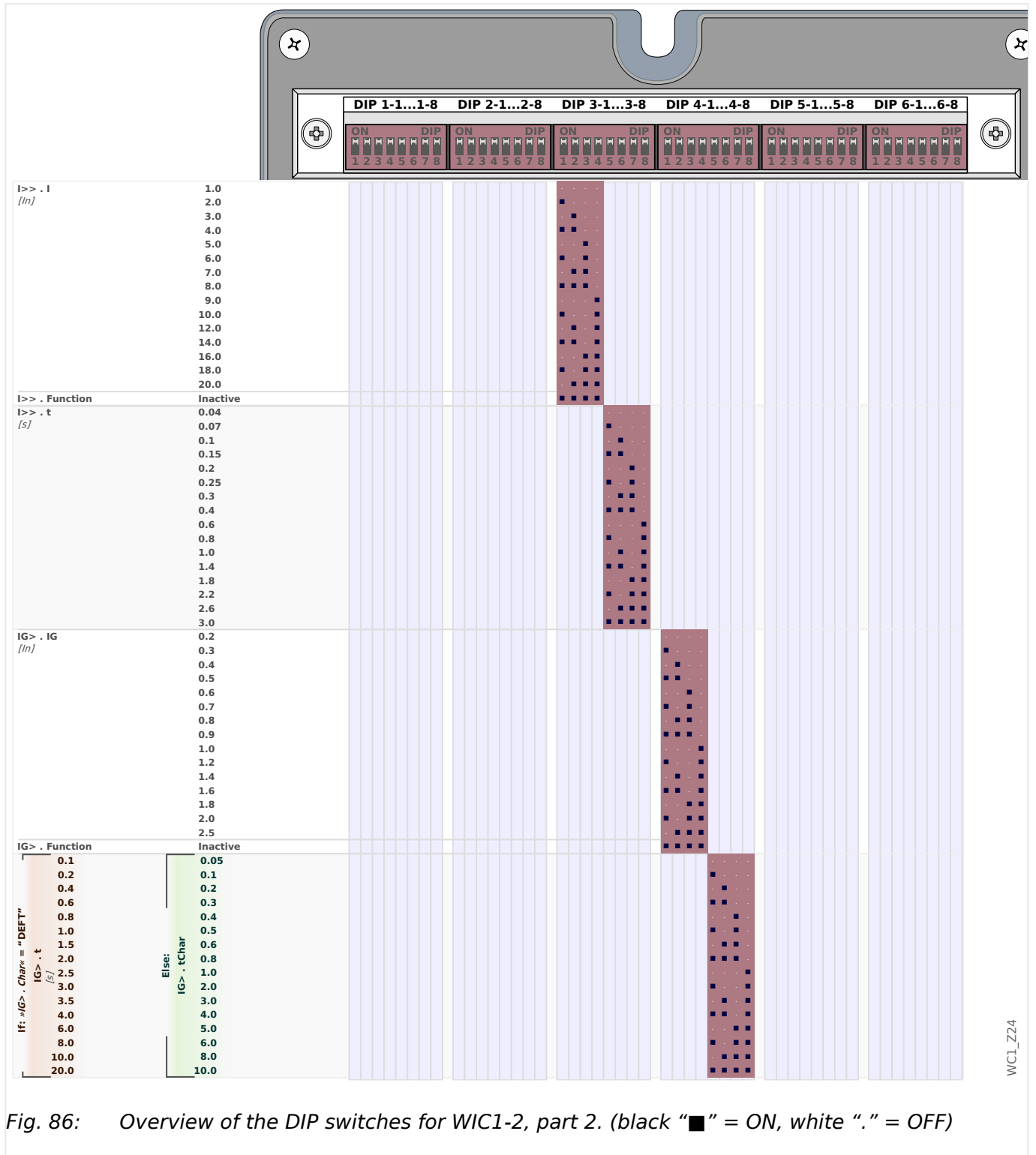
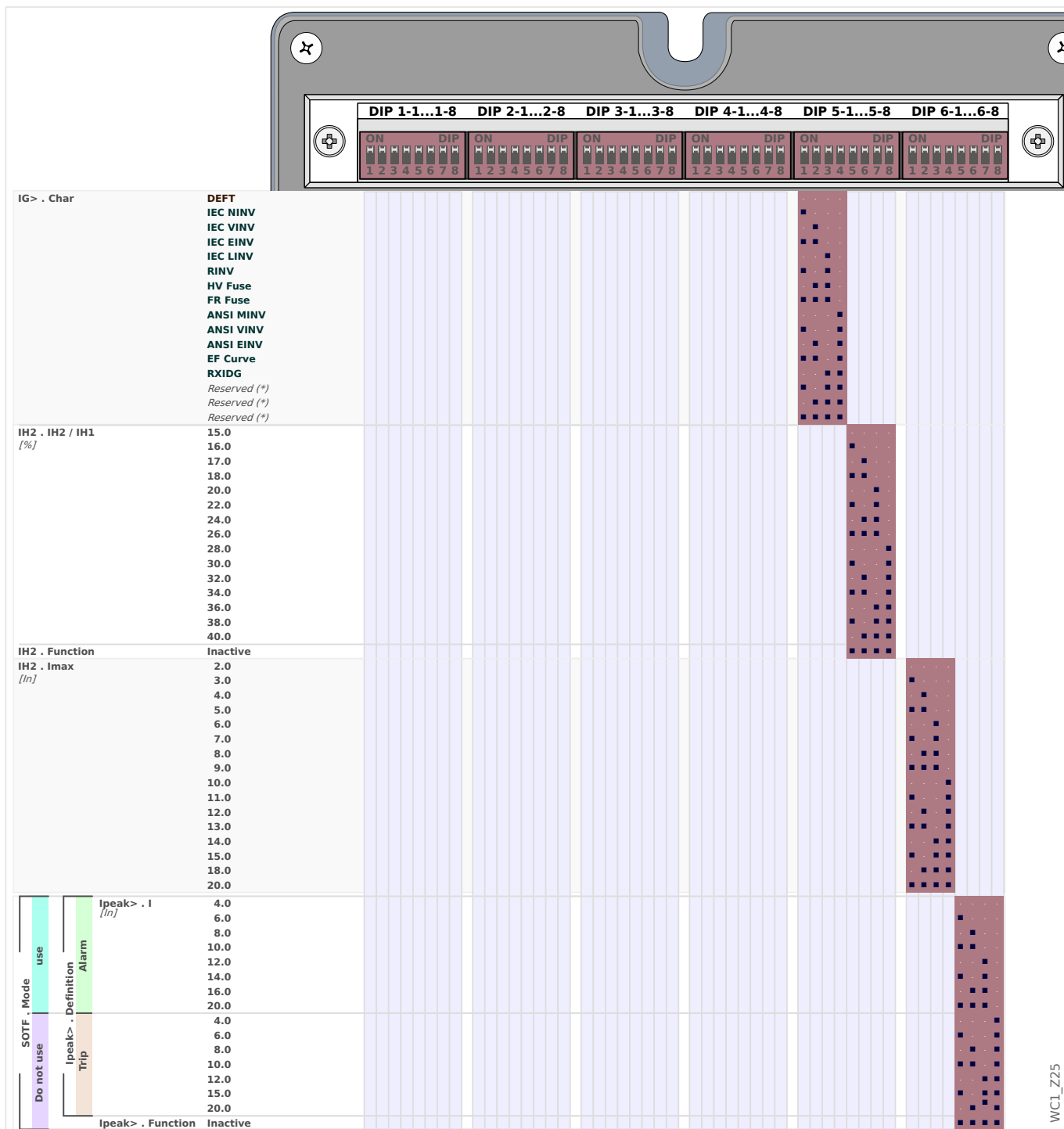

Fig. 86: Overview of the DIP switches for WIC1-2, part 2. (black "■" = ON, white "." = OFF)



WIC1\_Z25

Fig. 87: Overview of the DIP switches for WIC1-2, part 3. (black "■" = ON, white "." = OFF)

(\*) This switch setting is assigned to the DEFT characteristic but reserved for additional characteristics to be added with future WIC1 versions.

## 12.1.2 Settings via HEX Switches (WIC1-3)

For the WIC1-3, the following settings can be made directly at the device, using the built-in switches:

- Setting of the Rated CT current, see [↪](#) “12.1.3 Setting of the Rated CT current  $I_n$ ”.
- Setting of Characteristic, Pickup Current and Tripping Time / Characteristic Time of Phase Overcurrent Protection, stages  $I_{>}$  and  $I_{>>}$ , see [↪](#) “5.3.2 Phase Overcurrent Protection - Settings”.
- Setting of the Characteristic, Pickup Current and Tripping Time / Characteristic Time of the Earth (Ground) Overcurrent Protection, stage  $I_{G>}$ , see [↪](#) “5.5.2 Earth (Ground) Overcurrent Protection - Settings”.
- Setting of the harmonics ratio and maximum current for the Inrush Protection, see [↪](#) “5.4 IH2 - Inrush Blocking”.
- Setting of the Pickup Current and Supervision Mode for the Peak Overcurrent Protection, see [↪](#) “5.9  $I_{peak>}$  - Peak Overcurrent Protection”.

The upper eight HEX switches are compatible with the eight HEX switches of the first WIC1 version (except for the additional overcurrent characteristics).

Although the enhanced protection functionality has made us increase the number of HEX switches with this second WIC1 version, however, the total number of HEX switches is obviously limited by the size of the housing. Therefore some settings cannot be set via a switch. These settings can be set only via DigiMEC or via Smart view. However, SEG has selected the meanings of the switches with great care, so that the usual settings for typical applications should be covered.

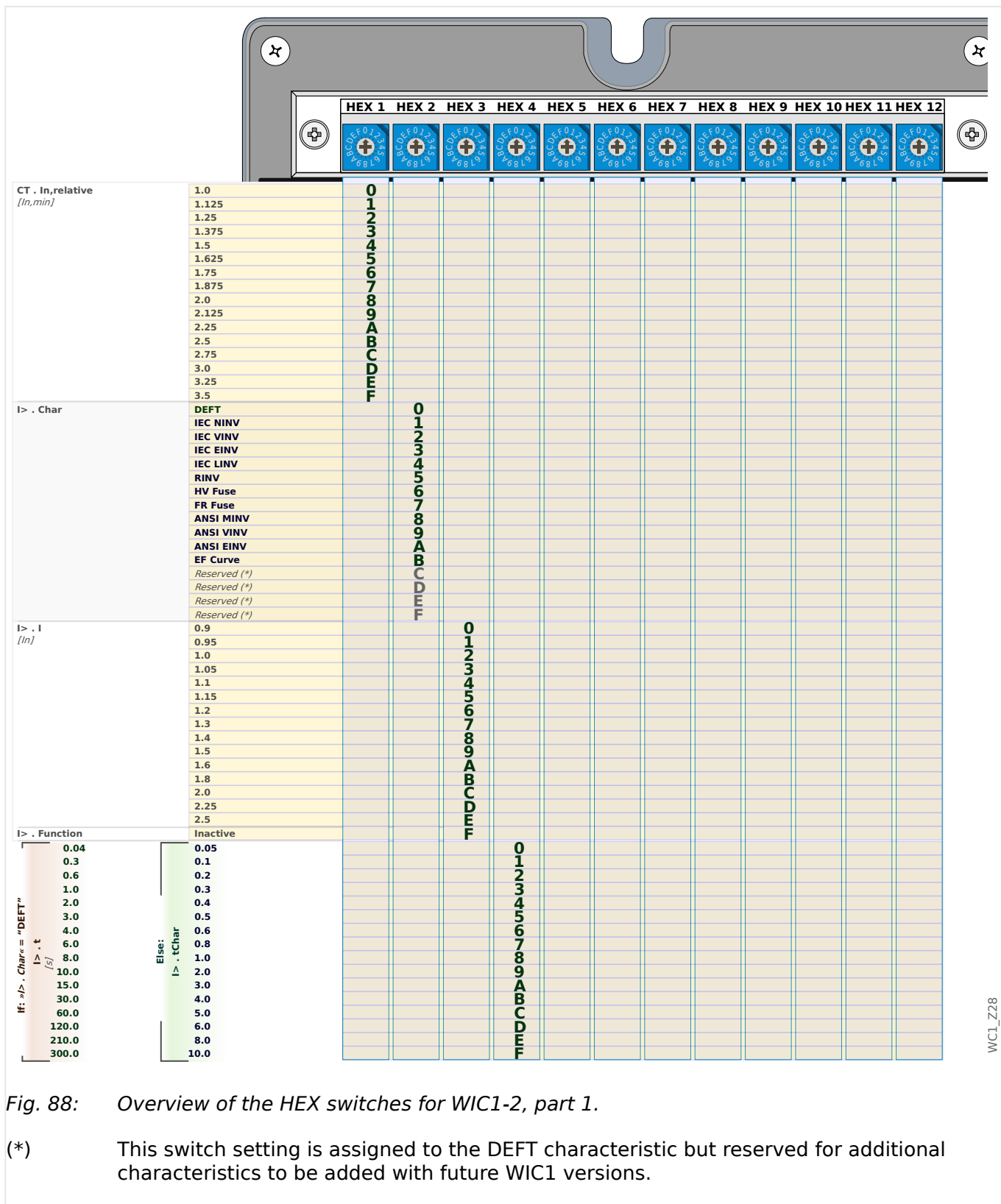

WIC1\_Z28

Fig. 88: Overview of the HEX switches for WIC1-2, part 1.

(\*) This switch setting is assigned to the DEFT characteristic but reserved for additional characteristics to be added with future WIC1 versions.

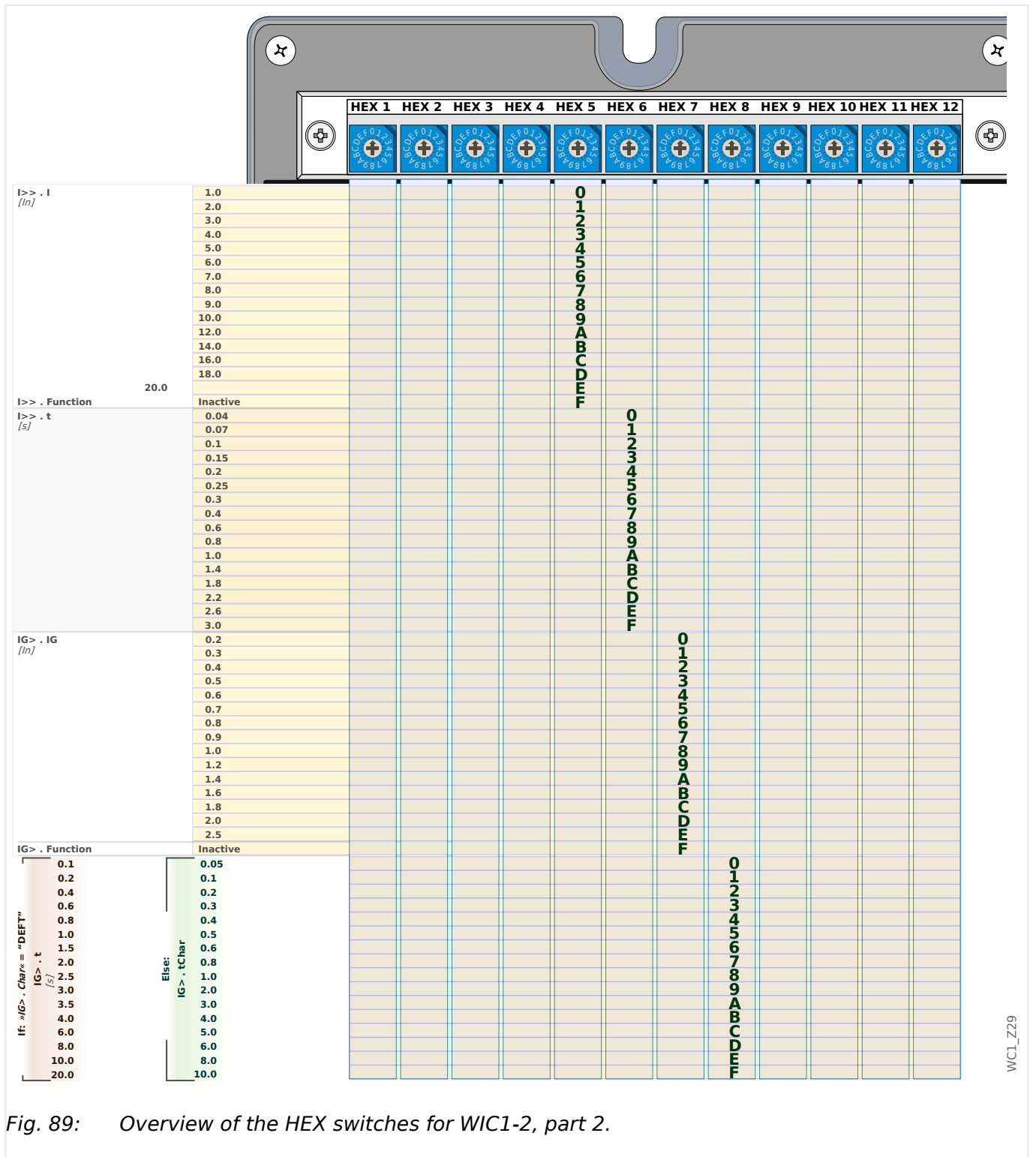

WIC1\_Z29

Fig. 89: Overview of the HEX switches for WIC1-2, part 2.



	HEX 1	HEX 2	HEX 3	HEX 4	HEX 5	HEX 6	HEX 7	HEX 8	HEX 9	HEX 10	HEX 11	HEX 12
IG> . Char	DEFT								0			
	IEC NINV								1			
	IEC VINV								2			
	IEC EINV								3			
	IEC LINV								4			
	RINV								5			
	HV Fuse								6			
	FR Fuse								7			
	ANSI MINV								8			
	ANSI VINV								9			
	ANSI EINV								A			
	EF Curve								B			
	RXIDG								C			
Reserved (*)								D				
Reserved (*)								E				
Reserved (*)								F				
IH2 . IH2 / IH1 [%]	15.0								0			
	16.0								1			
	17.0								2			
	18.0								3			
	20.0								4			
	22.0								5			
	24.0								6			
	26.0								7			
	28.0								8			
	30.0								9			
	32.0								A			
	34.0								B			
	36.0								C			
IH2 . Function IH2 . I <sub>max</sub> [In]	Inactive								D			
	2.0								E			
	3.0								F			
	4.0								0			
	5.0								1			
	6.0								2			
	7.0								3			
	8.0								4			
	9.0								5			
	10.0								6			
	11.0								7			
	12.0								8			
	13.0								9			
I <sub>peak</sub> > . I [In]	2.0								A			
	4.0								B			
	6.0								C			
	8.0								D			
	10.0								E			
	12.0								F			
	14.0								0			
	16.0								1			
	20.0								2			
	4.0								3			
	6.0								4			
	8.0								5			
	10.0								6			
12.0								7				
15.0								8				
20.0								9				
I <sub>peak</sub> > . Function	Inactive								A			
	4.0								B			
	6.0								C			
	8.0								D			
	10.0								E			
	12.0								F			
	15.0								0			
	20.0								1			
	4.0								2			
	6.0								3			
	8.0								4			
	10.0								5			
	12.0								6			
15.0								7				
20.0								8				
Inactive								9				

WIC1\_Z33

Fig. 90: Overview of the HEX switches for WIC1-2, part 3.

(\*) This switch setting is assigned to the DEFT characteristic but reserved for additional characteristics to be added with future WIC1 versions.

### 12.1.3 Setting of the Rated CT current In

#### WIC1-2: DIP switch block 1, switches 1...4

#### WIC1-3: HEX switch 1

The primary values in Ampere in the following tables depend on the CT type. (See also the considerations in [↳ “3.3.2 Selection of a WIC1-Compatible Current Transformer”](#).)

(CT types: See [↳ “2.6.1.3 Order Form of the WIC1-Compatible Current Transformers”](#))

Related setting via DiggiMEC or via Smart view:

- [Field Para / CT] »CT . *In,relative*«, see also [↳ “5.2 Field Parameters”](#).

This is a relative rated current in units of  $[I_{n,min}]$ , i. e. a rated current value without the CT type dependency.

**12.1.3.1 DIP-/HEX-Switch Settings for CT Types W2, WE2**

CT Type W2 or WE2 Primary Rated CT Current <i>I<sub>n</sub></i> in Ampere	Relative Rated Current » <i>I<sub>n,relative</sub></i> « in <i>I<sub>n,min</sub></i>  (Prim. Rated Current for WIC1- W2 = 16 · Relative Rated Current)	HEX 1	DIP 1-1	DIP 1-2	DIP 1-3	DIP 1-4
16	1.0	0	OFF	OFF	OFF	OFF
18	1.125	1	ON	OFF	OFF	OFF
20	1.25	2	OFF	ON	OFF	OFF
22	1.375	3	ON	ON	OFF	OFF
24	1.5	4	OFF	OFF	ON	OFF
26	1.625	5	ON	OFF	ON	OFF
28	1.75	6	OFF	ON	ON	OFF
30	1.875	7	ON	ON	ON	OFF
32	2.0	8	OFF	OFF	OFF	ON
34	2.125	9	ON	OFF	OFF	ON
36	2.25	A	OFF	ON	OFF	ON
40	2.5	B	ON	ON	OFF	ON
44	2.75	C	OFF	OFF	ON	ON
48	3.0	D	ON	OFF	ON	ON
52	3.25	E	OFF	ON	ON	ON
56	3.5	F	ON	ON	ON	ON

**12.1.3.2 DIP-/HEX-Switch Settings for CT Type W3**

CT Type W3 Primary Rated CT Current <i>I<sub>n</sub></i> in Ampere	Relative Rated Current » <i>I<sub>n,relative</sub></i> « in <i>I<sub>n,min</sub></i>  (Prim. Rated Current for WIC1- W3 = 32 · Relative Rated Current)	HEX 1	DIP 1-1	DIP 1-2	DIP 1-3	DIP 1-4
32	1.0	0	OFF	OFF	OFF	OFF
36	1.125	1	ON	OFF	OFF	OFF
40	1.25	2	OFF	ON	OFF	OFF
44	1.375	3	ON	ON	OFF	OFF
48	1.5	4	OFF	OFF	ON	OFF
52	1.625	5	ON	OFF	ON	OFF
56	1.75	6	OFF	ON	ON	OFF
60	1.875	7	ON	ON	ON	OFF
64	2.0	8	OFF	OFF	OFF	ON
68	2.125	9	ON	OFF	OFF	ON
72	2.25	A	OFF	ON	OFF	ON
80	2.5	B	ON	ON	OFF	ON
88	2.75	C	OFF	OFF	ON	ON
96	3.0	D	ON	OFF	ON	ON
104	3.25	E	OFF	ON	ON	ON
112	3.5	F	ON	ON	ON	ON

## 12.1.3.3 DIP-/HEX-Switch Settings for CT Type W4

CT Type W4 Primary Rated CT Current $I_n$ in Ampere	Relative Rated Current » $I_n,relative$ « in $I_{n,min}$  (Prim. Rated Current for WIC1- W4 = 64 · Relative Rated Current)	HEX 1	DIP 1-1	DIP 1-2	DIP 1-3	DIP 1-4
64	1.0	0	OFF	OFF	OFF	OFF
72	1.125	1	ON	OFF	OFF	OFF
80	1.25	2	OFF	ON	OFF	OFF
88	1.375	3	ON	ON	OFF	OFF
96	1.5	4	OFF	OFF	ON	OFF
104	1.625	5	ON	OFF	ON	OFF
112	1.75	6	OFF	ON	ON	OFF
120	1.875	7	ON	ON	ON	OFF
128	2.0	8	OFF	OFF	OFF	ON
136	2.125	9	ON	OFF	OFF	ON
144	2.25	A	OFF	ON	OFF	ON
160	2.5	B	ON	ON	OFF	ON
176	2.75	C	OFF	OFF	ON	ON
192	3.0	D	ON	OFF	ON	ON
208	3.25	E	OFF	ON	ON	ON
224	3.5	F	ON	ON	ON	ON

**12.1.3.4 DIP-/HEX-Switch Settings for CT Type W5**

<b>CT Type W5 Primary Rated CT Current <i>I<sub>n</sub></i> in Ampere</b>	<b>Relative Rated Current »<i>I<sub>n,relative</sub></i>« in <i>I<sub>n,min</sub></i>  (Prim. Rated Current for WIC1- W5 = 128 · Relative Rated Current)</b>	<b>HEX 1</b>	<b>DIP 1-1</b>	<b>DIP 1-2</b>	<b>DIP 1-3</b>	<b>DIP 1-4</b>
128	1.0	0	OFF	OFF	OFF	OFF
144	1.125	1	ON	OFF	OFF	OFF
160	1.25	2	OFF	ON	OFF	OFF
176	1.375	3	ON	ON	OFF	OFF
192	1.5	4	OFF	OFF	ON	OFF
208	1.625	5	ON	OFF	ON	OFF
224	1.75	6	OFF	ON	ON	OFF
240	1.875	7	ON	ON	ON	OFF
256	2.0	8	OFF	OFF	OFF	ON
272	2.125	9	ON	OFF	OFF	ON
288	2.25	A	OFF	ON	OFF	ON
320	2.5	B	ON	ON	OFF	ON
352	2.75	C	OFF	OFF	ON	ON
384	3.0	D	ON	OFF	ON	ON
416	3.25	E	OFF	ON	ON	ON
448	3.5	F	ON	ON	ON	ON

## 12.1.3.5 DIP-/HEX-Switch Settings for CT Type W6

CT Type W6 Primary Rated CT Current $I_n$ in Ampere	Relative Rated Current » $I_n,relative$ « in $I_{n,min}$  (Prim. Rated Current for WIC1- W6 = $256 \cdot$ Relative Rated Current)	HEX 1	DIP 1-1	DIP 1-2	DIP 1-3	DIP 1-4
256	1.0	0	OFF	OFF	OFF	OFF
288	1.125	1	ON	OFF	OFF	OFF
320	1.25	2	OFF	ON	OFF	OFF
352	1.375	3	ON	ON	OFF	OFF
384	1.5	4	OFF	OFF	ON	OFF
416	1.625	5	ON	OFF	ON	OFF
448	1.75	6	OFF	ON	ON	OFF
480	1.875	7	ON	ON	ON	OFF
512	2.0	8	OFF	OFF	OFF	ON
544	2.125	9	ON	OFF	OFF	ON
576	2.25	A	OFF	ON	OFF	ON
640	2.5	B	ON	ON	OFF	ON
704	2.75	C	OFF	OFF	ON	ON
768	3.0	D	ON	OFF	ON	ON
832	3.25	E	OFF	ON	ON	ON
896	3.5	F	ON	ON	ON	ON

### 12.1.4 Phase Overcurrent Protection - Settings via DIP Switches (WIC1-2) or via HEX Switches (WIC1-3)

**Setting of the Characteristic of Phase Overcurrent Protection Stage I>**

**WIC1-2: DIP switch block 1, switches 5...8**

**WIC1-3: HEX switch 2**

Characteristic »I> . Char«	HEX 2	DIP 1-5	DIP 1-6	DIP 1-7	DIP 1-8
DEFT	0	OFF	OFF	OFF	OFF
IEC NINV	1	ON	OFF	OFF	OFF
IEC VINV	2	OFF	ON	OFF	OFF
IEC EINV	3	ON	ON	OFF	OFF
IEC LINV	4	OFF	OFF	ON	OFF
RINV	5	ON	OFF	ON	OFF
HV Fuse	6	OFF	ON	ON	OFF
FR Fuse	7	ON	ON	ON	OFF
IEEE C37.2 MINV	8	OFF	OFF	OFF	ON
IEEE C37.2 VINV	9	ON	OFF	OFF	ON
IEEE C37.2 EINV	A	OFF	ON	OFF	ON
EF Curve	B	ON	ON	OFF	ON
(reserved *)	C	OFF	OFF	ON	ON
(reserved *)	D	ON	OFF	ON	ON
(reserved *)	E	OFF	ON	ON	ON
(reserved *)	F	ON	ON	ON	ON

(\*) This switch setting is assigned to the DEFT characteristic but reserved for additional characteristics to be added with future WIC1 versions.



**Setting of the Pickup Current of Phase Overcurrent Protection Stage I >****WIC1-2: DIP switch block 2, switches 1...4****WIC1-3: HEX switch 3**

If “DEFT” is set as the characteristic ([↪ “Setting of the Characteristic of Phase Overcurrent Protection Stage I >”](#)) this is the setting  $I_{>}$  for the pickup current.

If any of the inverse characteristics is set ([↪ “Setting of the Characteristic of Phase Overcurrent Protection Stage I >”](#)) this is the start value of the inverse-time characteristic.

The pickup currents in this table are given in units of the rated CT current  $I_n$ . ([↪ “12.1.3 Setting of the Rated CT current  \$I\_n\$ ”](#))

Pickup » $I_{>}$ . $I_{<<}$ (as a multiple of $I_n$ )	HEX 3	DIP 2-1	DIP 2-2	DIP 2-3	DIP 2-4
0.90	0	OFF	OFF	OFF	OFF
0.95	1	ON	OFF	OFF	OFF
1.00	2	OFF	ON	OFF	OFF
1.05	3	ON	ON	OFF	OFF
1.10	4	OFF	OFF	ON	OFF
1.15	5	ON	OFF	ON	OFF
1.20	6	OFF	ON	ON	OFF
1.30	7	ON	ON	ON	OFF
1.40	8	OFF	OFF	OFF	ON
1.50	9	ON	OFF	OFF	ON
1.60	A	OFF	ON	OFF	ON
1.80	B	ON	ON	OFF	ON
2.00	C	OFF	OFF	ON	ON
2.25	D	ON	OFF	ON	ON
2.50	E	OFF	ON	ON	ON
This setting deactivates the protection stage.	F	ON	ON	ON	ON

**Setting of the Tripping Delay or »tChar« Factor of the Phase Overcurrent Protection Stage I>**

**WIC1-2: DIP switch block 2, switches 5...8**

**WIC1-3: HEX switch 4**

If “DEFT” is set as the characteristic ( [↪ “Setting of the Characteristic of Phase Overcurrent Protection Stage I>”](#) ) this is the setting for the tripping delay in seconds.

If any of the inverse characteristics is set ( [↪ “Setting of the Characteristic of Phase Overcurrent Protection Stage I>”](#) ) this is the »tChar« factor of the inverse-time characteristic.

Tripping Delay »I> . t« in seconds	Characteristic Factor »I> . tChar«	HEX 4	DIP 2-5	DIP 2-6	DIP 2-7	DIP 2-8
0.04	0.05	0	OFF	OFF	OFF	OFF
0.3	0.1	1	ON	OFF	OFF	OFF
0.6	0.2	2	OFF	ON	OFF	OFF
1.0	0.3	3	ON	ON	OFF	OFF
2.0	0.4	4	OFF	OFF	ON	OFF
3.0	0.5	5	ON	OFF	ON	OFF
4.0	0.6	6	OFF	ON	ON	OFF
6.0	0.8	7	ON	ON	ON	OFF
8.0	1	8	OFF	OFF	OFF	ON
10.0	2	9	ON	OFF	OFF	ON
15.0	3	A	OFF	ON	OFF	ON
30.0	4	B	ON	ON	OFF	ON
60.0	5	C	OFF	OFF	ON	ON
120.0	6	D	ON	OFF	ON	ON
210.0	8	E	OFF	ON	ON	ON
300.0	10	F	ON	ON	ON	ON

**Setting of the Pickup Current of Phase Overcurrent Protection Stage I>>****WIC1-2: DIP switch block 3, switches 1...4****WIC1-3: HEX switch 5**

This is the setting for the pickup current of the short-circuit element I>>.

The pickup currents in this table are given in units of the rated CT current  $I_n$ . ([↪](#) “12.1.3 Setting of the Rated CT current  $I_n$ ”)

Pickup »I>> . I« (as a multiple of $I_n$ )	HEX 5	DIP 3-1	DIP 3-2	DIP 3-3	DIP 3-4
1	0	OFF	OFF	OFF	OFF
2	1	ON	OFF	OFF	OFF
3	2	OFF	ON	OFF	OFF
4	3	ON	ON	OFF	OFF
5	4	OFF	OFF	ON	OFF
6	5	ON	OFF	ON	OFF
7	6	OFF	ON	ON	OFF
8	7	ON	ON	ON	OFF
9	8	OFF	OFF	OFF	ON
10	9	ON	OFF	OFF	ON
12	A	OFF	ON	OFF	ON
14	B	ON	ON	OFF	ON
16	C	OFF	OFF	ON	ON
18	D	ON	OFF	ON	ON
20	E	OFF	ON	ON	ON
This setting deactivates the protection stage.	F	ON	ON	ON	ON

**Setting of the Tripping Delay of Phase Overcurrent Protection Stage I>>**

**WIC1-2: DIP switch block 3, switches 5...8**

**WIC1-3: HEX switch 6**

This is the setting for the tripping delay of the short-circuit protection »I>>« in seconds.

Tripping Delay »I>> . t« in seconds	HEX 6	DIP 3-5	DIP 3-6	DIP 3-7	DIP 3-8
0.04	0	OFF	OFF	OFF	OFF
0.07	1	ON	OFF	OFF	OFF
0.1	2	OFF	ON	OFF	OFF
0.15	3	ON	ON	OFF	OFF
0.2	4	OFF	OFF	ON	OFF
0.25	5	ON	OFF	ON	OFF
0.3	6	OFF	ON	ON	OFF
0.4	7	ON	ON	ON	OFF
0.6	8	OFF	OFF	OFF	ON
0.8	9	ON	OFF	OFF	ON
1.0	A	OFF	ON	OFF	ON
1.4	B	ON	ON	OFF	ON
1.8	C	OFF	OFF	ON	ON
2.2	D	ON	OFF	ON	ON
2.6	E	OFF	ON	ON	ON
3.0	F	ON	ON	ON	ON

## 12.1.5 Earth (Ground) Overcurrent Protection - Settings via DIP Switches (WIC1-2) or via HEX Switches (WIC1-3)

### **Setting of the Characteristic of the Earth (Ground) Overcurrent Protection Stage IG>**

**WIC1-2: DIP switch block 5, switches 1...4**

**WIC1-3: HEX switch 9**

Characteristic »IG> . Char«	HEX 9	DIP 5-1	DIP 5-2	DIP 5-3	DIP 5-4
DEFT	0	OFF	OFF	OFF	OFF
IEC NINV	1	ON	OFF	OFF	OFF
IEC VINV	2	OFF	ON	OFF	OFF
IEC EINV	3	ON	ON	OFF	OFF
IEC LINV	4	OFF	OFF	ON	OFF
RINV	5	ON	OFF	ON	OFF
HV Fuse	6	OFF	ON	ON	OFF
FR Fuse	7	ON	ON	ON	OFF
IEEE C37.2 MINV	8	OFF	OFF	OFF	ON
IEEE C37.2 VINV	9	ON	OFF	OFF	ON
IEEE C37.2 EINV	A	OFF	ON	OFF	ON
EF Curve	B	ON	ON	OFF	ON
RXIDG	C	OFF	OFF	ON	ON
(reserved *)	D	ON	OFF	ON	ON
(reserved *)	E	OFF	ON	ON	ON
(reserved *)	F	ON	ON	ON	ON

(\*) This switch setting is assigned to the DEFT characteristic but reserved for additional characteristics to be added with future WIC1 versions.

### **Setting of the Pickup Current of the Earth (Ground) Overcurrent Protection Stage IG>**

**WIC1-2: DIP switch block 4, switches 1...4**

**WIC1-3: HEX switch 7**

The pickup currents in this table are given in units of the rated CT current  $I_n$ .

**NOTICE!**



The „nominal current“ (rated current)  $I_n$  is for all Earth (Ground) Overcurrent stages dependent on whether the ground (earth) current is measured or calculated. This is especially true of all settings parameters that are defined in units of  $I_n$ .

- Measured ground (earth) current, [Field Para / General Settings] »CT . IG Source« = “measured”:

$I_n$  is the rated current of the ground (earth) CT, and the WIC1 currently supports 1 A ground (earth) CTs.

- Calculated ground (earth) current, [Field Para / General Settings] »CT . IG Source« = “calculated”:

$I_n$  is the rated current of the phase CTs, and this corresponds to the setting [Field Para / CT] »CT . In,relative«. (See also [↪](#) “12.1.3 Setting of the Rated CT current  $I_n$ ” and [↪](#) “5.2 Field Parameters”.)

Pickup »IG> . IG« (as a multiple of $I_n$ )	HEX 7	DIP 4-1	DIP 4-2	DIP 4-3	DIP 4-4
0.2	0	OFF	OFF	OFF	OFF
0.3	1	ON	OFF	OFF	OFF
0.4	2	OFF	ON	OFF	OFF
0.5	3	ON	ON	OFF	OFF
0.6	4	OFF	OFF	ON	OFF
0.7	5	ON	OFF	ON	OFF
0.8	6	OFF	ON	ON	OFF
0.9	7	ON	ON	ON	OFF
1.0	8	OFF	OFF	OFF	ON
1.2	9	ON	OFF	OFF	ON
1.4	A	OFF	ON	OFF	ON
1.6	B	ON	ON	OFF	ON
1.8	C	OFF	OFF	ON	ON
2.0	D	ON	OFF	ON	ON
2.5	E	OFF	ON	ON	ON
This setting deactivates the protection stage.	F	ON	ON	ON	ON

### Setting of the Tripping Delay »t« or »tChar« Factor of the Earth (Ground) Overcurrent Protection Stage IG>

**WIC1-2: DIP switch block 4, switches 5...8**

**WIC1-3: HEX switch 8**

If "DEFT" is set as the characteristic ( [↳ "Setting of the Characteristic of the Earth \(Ground\) Overcurrent Protection Stage IG>"](#) ) this is the setting for the tripping delay in seconds.

If any of the inverse characteristics is set ( [↳ "Setting of the Characteristic of the Earth \(Ground\) Overcurrent Protection Stage IG>"](#) ) this is the »tChar« factor of the inverse-time characteristic.

Tripping Delay »IG> . t« in seconds	Characteristic Factor »IG> . tChar«	HEX 8	DIP 4-5	DIP 4-6	DIP 4-7	DIP 4-8
0.1	0.05	0	OFF	OFF	OFF	OFF
0.2	0.1	1	ON	OFF	OFF	OFF
0.4	0.2	2	OFF	ON	OFF	OFF
0.6	0.3	3	ON	ON	OFF	OFF
0.8	0.4	4	OFF	OFF	ON	OFF
1.0	0.5	5	ON	OFF	ON	OFF
1.5	0.6	6	OFF	ON	ON	OFF
2.0	0.8	7	ON	ON	ON	OFF
2.5	1	8	OFF	OFF	OFF	ON
3.0	2	9	ON	OFF	OFF	ON
3.5	3	A	OFF	ON	OFF	ON
4.0	4	B	ON	ON	OFF	ON
6.0	5	C	OFF	OFF	ON	ON
8.0	6	D	ON	OFF	ON	ON
10.0	8	E	OFF	ON	ON	ON
20.0	10	F	ON	ON	ON	ON

### 12.1.6 Inrush - Settings via DIP Switches (WIC1-2) or via HEX Switches (WIC1-3)

- For device variants with DIP/HEX switches and **without** ground current measurement (WIC1-xxN), the [Inrush Blocking module](#) always also blocks the [ground overcurrent protection](#).
- For device variants with DIP/HEX switches and **with** ground current measurement (WIC1-xxG), there is no such blocking of the [ground overcurrent protection](#).

**Threshold »IH2 / IH1«**

**WIC1-2: DIP switch block 5, switches 5...8**

**WIC1-3: HEX switch 10**

The »IH2 / IH1« values are percentages, that specify the ratio of the 2<sup>nd</sup> harmonic to the 1<sup>st</sup> harmonic.

Related setting via DiggiMEC or via Smart view:

- [Protection Para / IH2] »IH2 . IH2 / IH1«,  
see  “5.4.2.1 Inrush – Settings via DiggiMEC or via Smart view”,

Threshold »IH2 / IH1«	HEX 10	DIP 5-5	DIP 5-6	DIP 5-7	DIP 5-8
15.0	0	OFF	OFF	OFF	OFF
16.0	1	ON	OFF	OFF	OFF
17.0	2	OFF	ON	OFF	OFF
18.0	3	ON	ON	OFF	OFF
20.0	4	OFF	OFF	ON	OFF
22.0	5	ON	OFF	ON	OFF
24.0	6	OFF	ON	ON	OFF
26.0	7	ON	ON	ON	OFF
28.0	8	OFF	OFF	OFF	ON
30.0	9	ON	OFF	OFF	ON
32.0	A	OFF	ON	OFF	ON
34.0	B	ON	ON	OFF	ON
36.0	C	OFF	OFF	ON	ON
38.0	D	ON	OFF	ON	ON
40.0	E	OFF	ON	ON	ON
This setting deactivates the Inrush Blocking.	F	ON	ON	ON	ON



**Threshold »I<sub>max</sub>«****WIC1-2: DIP switch block 6, switches 1...4****WIC1-3: HEX switch 11**

The Inrush threshold current »I<sub>max</sub>« in this table is given in units of the rated CT current I<sub>n</sub>.  
 (↳ “12.1.3 Setting of the Rated CT current I<sub>n</sub>”)

Related setting via DiggiMEC or via Smart view:

- [Protection Para / IH2] »IH2 . I<sub>max</sub>«,

see ↳ “5.4.2.1 Inrush – Settings via DiggiMEC or via Smart view”.

Threshold »I <sub>max</sub> « (as a multiple of I <sub>n</sub> )	HEX 11	DIP 6-1	DIP 6-2	DIP 6-3	DIP 6-4
2.0	0	OFF	OFF	OFF	OFF
3.0	1	ON	OFF	OFF	OFF
4.0	2	OFF	ON	OFF	OFF
5.0	3	ON	ON	OFF	OFF
6.0	4	OFF	OFF	ON	OFF
7.0	5	ON	OFF	ON	OFF
8.0	6	OFF	ON	ON	OFF
9.0	7	ON	ON	ON	OFF
10.0	8	OFF	OFF	OFF	ON
11.0	9	ON	OFF	OFF	ON
12.0	A	OFF	ON	OFF	ON
13.0	B	ON	ON	OFF	ON
14.0	C	OFF	OFF	ON	ON
15.0	D	ON	OFF	ON	ON
18.0	E	OFF	ON	ON	ON
20.0	F	ON	ON	ON	ON

### 12.1.7 Ipeak> - Settings via DIP Switches (WIC1-2) or via HEX Switches (WIC1-3)

**WIC1-2: DIP switch block 6, switches 5...8**

**WIC1-3: HEX switch 12**

**WARNING!**



Be careful, as this switch sets several parameters from both Ipeak> and SOTF protection.

See also [↪ “5.9.2.1 Ipeak> - Settings via DigiMEC or via Smart view”](#) (and [↪ “5.10 SOTF - Switch Onto Fault”](#)).

Pick-up »Ipeak> . I« (as a multiple of In)	»Ipeak> . Definition«	»SOTF . Mode« =	HEX 12	DIP 6-5	DIP 6-6	DIP 6-7	DIP 6-8
4.0	Alarm	use	0	OFF	OFF	OFF	OFF
6.0	Alarm	use	1	ON	OFF	OFF	OFF
8.0	Alarm	use	2	OFF	ON	OFF	OFF
10.0	Alarm	use	3	ON	ON	OFF	OFF
12.0	Alarm	use	4	OFF	OFF	ON	OFF
14.0	Alarm	use	5	ON	OFF	ON	OFF
16.0	Alarm	use	6	OFF	ON	ON	OFF
20.0	Alarm	use	7	ON	ON	ON	OFF
4.0	Trip	Inactive	8	OFF	OFF	OFF	ON
6.0	Trip	Inactive	9	ON	OFF	OFF	ON
8.0	Trip	Inactive	A	OFF	ON	OFF	ON
10.0	Trip	Inactive	B	ON	ON	OFF	ON
12.0	Trip	Inactive	C	OFF	OFF	ON	ON
15.0	Trip	Inactive	D	ON	OFF	ON	ON
20.0	Trip	Inactive	E	OFF	ON	ON	ON
This setting deactivates the Ipeak> protection and the »SOTF« protection.			F	ON	ON	ON	ON

## 12.2 Appendix – Time Overcurrent Characteristics

### 12.2.1 Characteristics ( $I>$ , $I>>$ , $I>>>$ )

For each phase overcurrent stage, the following characteristics are available:

- **DEFT** – *Definite Time-Overcurrent*
- **Inverse-Time Overcurrent Curves according to IEC 60255-151:**
  - **NINV** – *IEC Normal Inverse* (IEC 60255-151)
  - **VINV** – *IEC Very Inverse* (IEC 60255-151)
  - **LINV** – *IEC Long Time Inverse* (IEC 60255-151)
  - **EINV** – *IEC Extremely Inverse* (IEC 60255-151)
- **RINV** – *R Inverse*
- **HV Fuse** Fuse Characteristic of an HV Fuse
- **FR Fuse** Fuse Characteristic of a Full Range Fuse
- **Curves Defined in IEEE C37.112:**
  - **MINV** – *IEEE Moderately Inverse* (IEEE C37.112)
  - **VINV** – *IEEE Very Inverse* (IEEE C37.112)
  - **EINV** – *IEEE Extremely Inverse* (IEEE C37.112)
- **EF Curve** “EF” Curve

#### **Explanation for All Characteristics ( $I>$ , $I>>$ , $I>>>$ )**

(Remark: All settings are given for protection stage » $I>$ «. » $I>>$ « and » $I>>>$ « have the same settings with corresponding menu branches.)

- **I**: Fault current
- **$I>$  =  $I_{>}$** : Pickup value for the Phase Overcurrent stage. If the pickup value is exceeded, the stage starts to time out to trip.  
Setting: [Protection Para /  $I>$ ] » $I$ «
- Trip delay  $t$  for  $I > I_{>}$ :
  - for »Char« = “DEFT”: settable via [Protection Para /  $I>$ ] » $t$ «.
  - for all other characteristics: calculated based on the selected curve.
- Reset mode for  $I < I_{>}$ , settable via »Reset Mode«, available options:
  - With option »Reset Mode« = “instantaneous”: Instantaneous reset: when the current drops below the pickup setting, the TOC time resets to zero within 2 cycles.
  - With option »Reset Mode« = “definite time”: The reset delay is settable at » $t_{Reset}$ «.

- With option »Reset Mode« = “inverse time” (only available for IEC and ANSI/IEEE curves): The reset delay is calculated based on the selected characteristics.
- $t_{Char}$  (for all characteristics except “DEFT”):
  - Time multiplier/tripping characteristic factor. The setting range depends on the selected tripping curve.
  - Setting via [Protection Para /  $I_{>}$ ] » $t_{Char}$ «

For all inverse-time characteristics (i. e. all curves except the DEFT), there are two minimum trip delays, and independent of the selected characteristic will the actual trip delay never be smaller than any of these two minimum delays.

- » $I_{>}$  .  $t_{Min}$ « is a minimum delay settable by the user. So, this is simply a timer that is triggered independent of the inverse-time curve and that has to elapse before the protection stage trips. If it is set to 0 seconds it is deactivated. (See also [↪](#) “5.3.2.1 Phase Overcurrent Protection - Settings via DiggiMEC or via Smart view”.)
- Another minimum delay,  $t_{Dyn.Lim.}$ , results from a calculated “knee-point” of the characteristic. This means it is dependent on a particular current value on the curve,  $I_{Dyn.Lim.}$ . The effective trip delay does never fall below  $t_{Dyn.Lim.}$ , independent of the actual value of  $I$ .
  - $I_{Dyn.Lim.}$  is defined as the smallest value out of  $20 \cdot I_n$  and  $20 \cdot I_{>}$  (EF Curve:  $30 \cdot I_{>}$ ).
  - Then  $t_{Dyn.Lim.}$  is the delay time that is calculated from this  $I_{Dyn.Lim.}$  based on the selected characteristic.
  - (The diagram of each characteristic curve shows this “knee-point”, assuming the example value  $I_{Dyn.Lim.} = 20 \cdot I_{>}$  [EF Curve:  $30 \cdot I_{>}$ ].)

### 12.2.1.1 DEFT - Definite Time-Overcurrent ( $I >$ , $I >>$ , $I >>>$ )

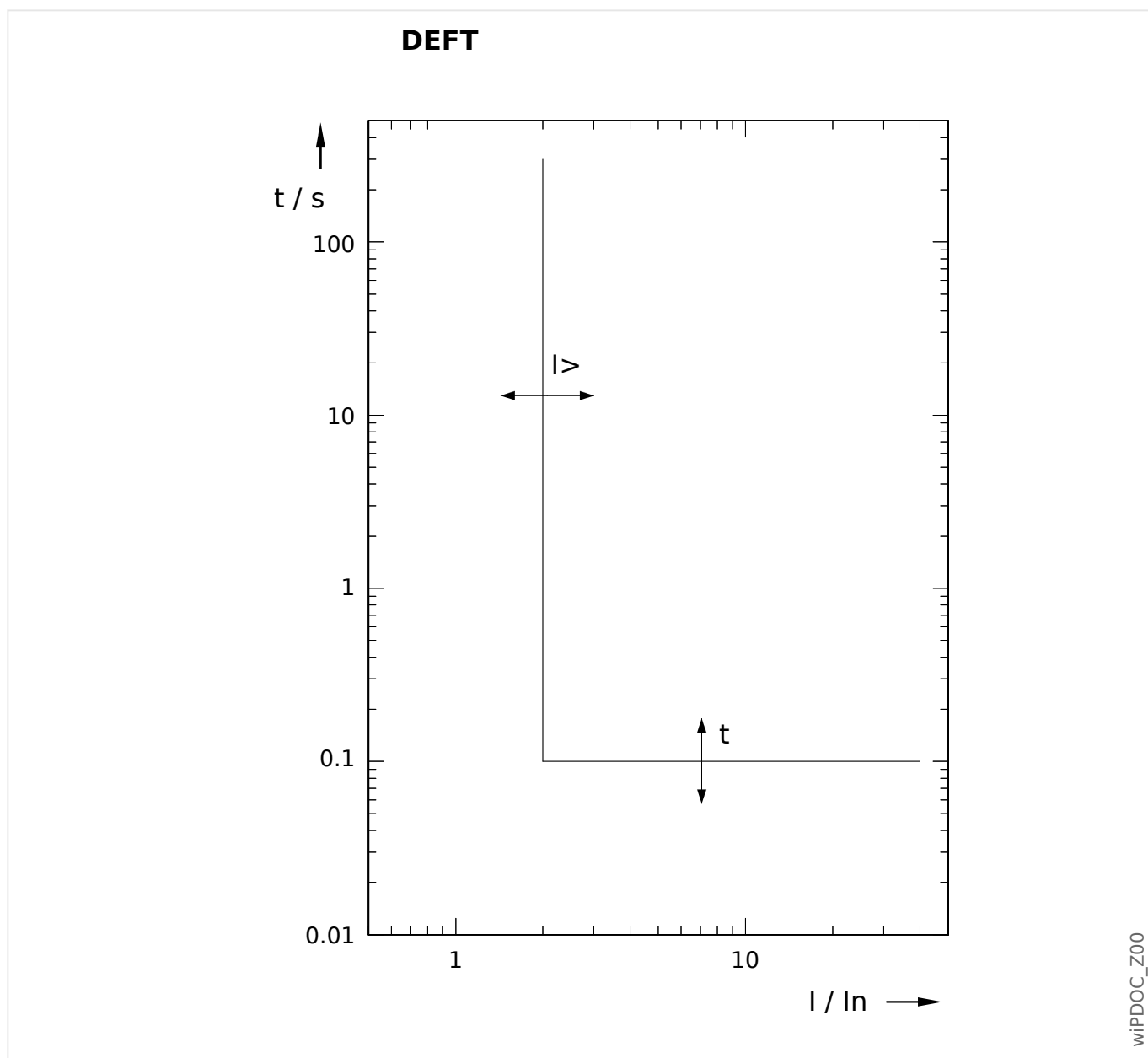

Trip delay for  $I > I_{>}$ , settable via [Protection Para /  $I >$ ] »t«.

The reset delay for  $I < I_{>}$  always equals 0 ("instantaneous").

**12.2.1.2 Inverse-Time Characteristics (I>, I>>, I>>>)**

Characteristic »Char«	Trip Delay			Reset Delay (only for »Reset Mode« = "inverse time")	
	$t = \left( \frac{k}{\left(\frac{I}{I>}\right)^\alpha - 1} + c \right) \cdot tChar$			$t = \frac{\tau}{1 - \left(\frac{I}{I>}\right)^\alpha} \cdot tChar$	
	k [s]	c [s]	α	τ [s]	α
IEC NINV	0.14	0	0.02	0.14	2
IEC VINV	13.5	0	1	13.5	2
IEC EINV	80	0	2	80	2
IEC LINV	120	0	1	120	2
IEEE MINV	0.0515	0.1140	0.02	4.85	2
IEEE VINV	19.61	0.491	1	21.6	2
IEEE EINV	28.2	0.1217	2	29.1	2

Characteristic »Char«	Trip Delay			Reset Delay (only for »Reset Mode« = "inverse time")	
	$t = \frac{k}{b - \frac{c}{\left(\frac{I}{I>}\right)}} \cdot tChar$			$t = \frac{\tau}{1 - \left(\frac{I}{I>}\right)^\alpha} \cdot tChar$	
	k [s]	b	c	τ [s]	α
RINV	1.0	0.339	0.236	1.0	2

Characteristic »Char«		Trip Delay			
		$t = k \cdot t_{Char} \cdot 10^{\alpha \cdot \log(b \cdot \frac{I}{I_>}) + c}$			
		k [s]	b	c	$\alpha$
HV Fuse		10	2	3.66	-3.8320
FR Fuse	$1 < \frac{I}{I_>} < 2$	10	1	3.0	-7.16
	$2 < \frac{I}{I_>} < 2.66$	10	1	2.47	-5.4
	$2.66 < \frac{I}{I_>} < \frac{I_{max}}{I_>}$	10	1	1.98	-4.24

See [↳](#) “Explanation for All Characteristics ( $I_>$ ,  $I_{>>}$ ,  $I_{>>>}$ )” for more information.

»Char« = IEC NINV

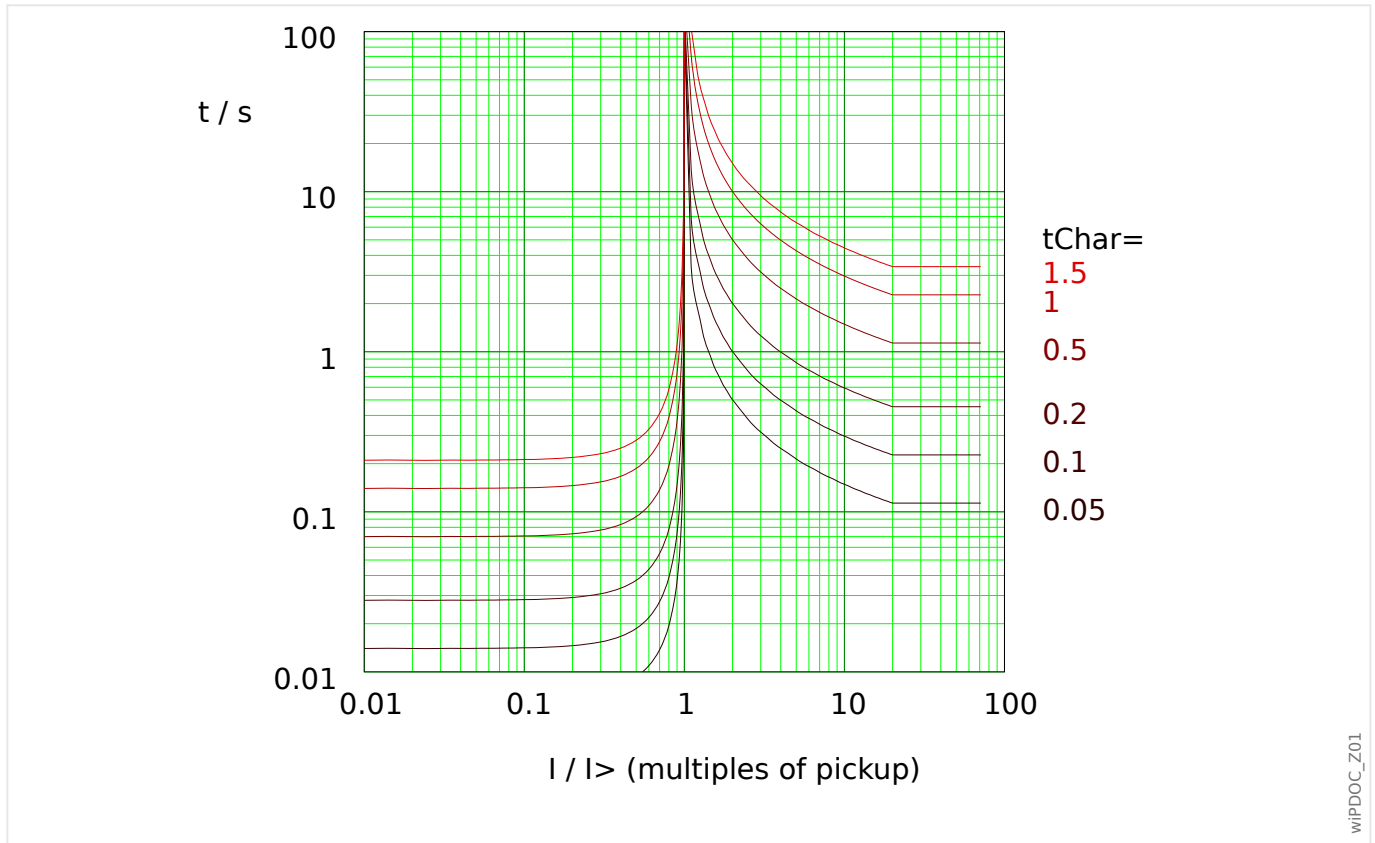

Fig. 91: NINV: reset delay (left half,  $I < I_{>}$ ) and trip delay (right half,  $I > I_{>}$ ), example for  $I_{Dyn.Lim.} = 20 \cdot I_{>}$ .

See [↳ “Explanation for All Characteristics \(I<sub>></sub>, I<sub>>></sub>, I<sub>>>></sub>\)”](#) and [↳ “12.2.1.2 Inverse-Time Characteristics \(I<sub>></sub>, I<sub>>></sub>, I<sub>>>></sub>\)”](#) for details.

**Reset Delay**

Various reset modes are available: Resetting [via characteristic](#), delayed and instantaneous.

**Trip Delay**

If  $I_{>} < I < I_{Dyn.Lim.}$ , the trip delay is defined [by the characteristic](#).

For  $I > I_{Dyn.Lim.}$ , the trip delay  $t$  is kept constant at  $t = t_{Dyn.Lim.}$ .



## 12.2.1.2.1.2 Very Inverse [VINV] (IEC 60255-151)

»Char« = IEC VINV

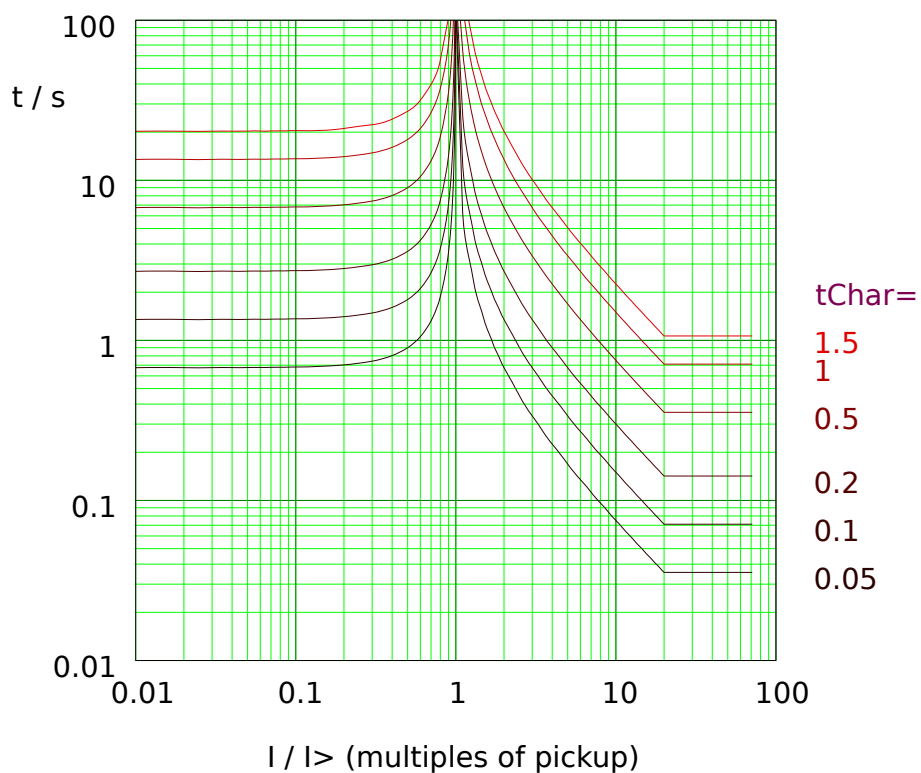

Fig. 92: VINV: reset delay (left half,  $I < I_{>}$ ) and trip delay (right half,  $I > I_{>}$ ), example for  $I_{Dyn.Lim.} = 20 \cdot I_{>}$ .

See [↳](#) “Explanation for All Characteristics ( $I_{>}$ ,  $I_{>>}$ ,  $I_{>>>}$ )” and [↳](#) “12.2.1.2 Inverse-Time Characteristics ( $I_{>}$ ,  $I_{>>}$ ,  $I_{>>>}$ )” for details.

### Reset Delay

Various reset modes are available: Resetting [via characteristic](#), delayed and instantaneous.

### Trip Delay

If  $I_{>} < I < I_{Dyn.Lim.}$ , the trip delay is defined [by the characteristic](#).

For  $I > I_{Dyn.Lim.}$ , the trip delay  $t$  is kept constant at  $t = t_{Dyn.Lim.}$ .

»Char« = IEC EINV

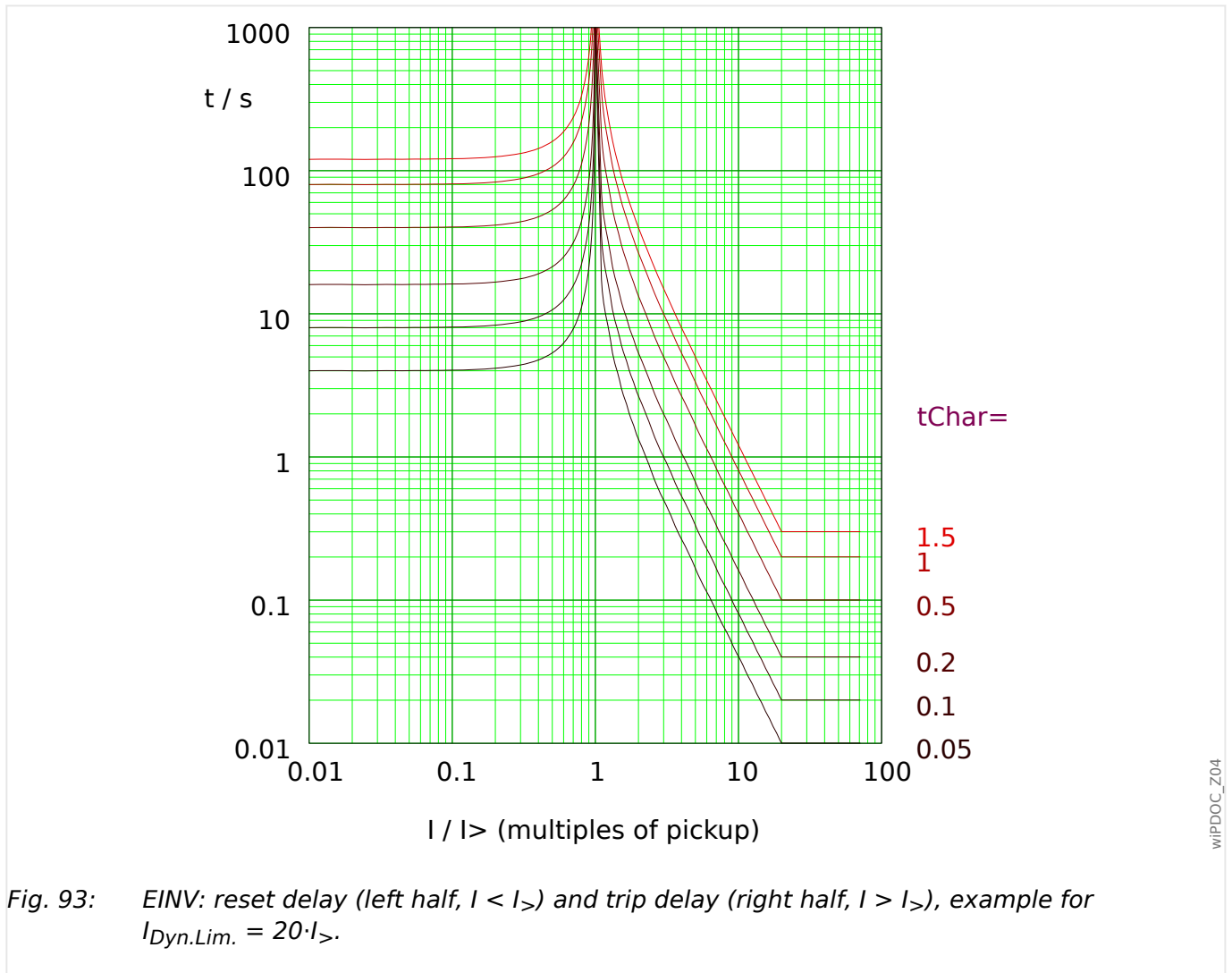

Fig. 93: EINV: reset delay (left half,  $I < I_{>}$ ) and trip delay (right half,  $I > I_{>}$ ), example for  $I_{Dyn.Lim.} = 20 \cdot I_{>}$ .

See [“Explanation for All Characteristics \( \$I\_{>}\$ ,  \$I\_{>>}\$ ,  \$I\_{>>>}\$ \)”](#) and [“12.2.1.2 Inverse-Time Characteristics \( \$I\_{>}\$ ,  \$I\_{>>}\$ ,  \$I\_{>>>}\$ \)”](#) for details.

**Reset Delay**

Various reset modes are available: Resetting [via characteristic](#), delayed and instantaneous.

**Trip Delay**

If  $I_{>} < I < I_{Dyn.Lim.}$ , the trip delay is defined [by the characteristic](#).

For  $I > I_{Dyn.Lim.}$ , the trip delay  $t$  is kept constant at  $t = t_{Dyn.Lim.}$ .

## 12.2.1.2.1.4 Long Time Inverse - Characteristic [LINV] (IEC 60255-151) - Phase Overcurrent Protection

»Char« = IEC LINV

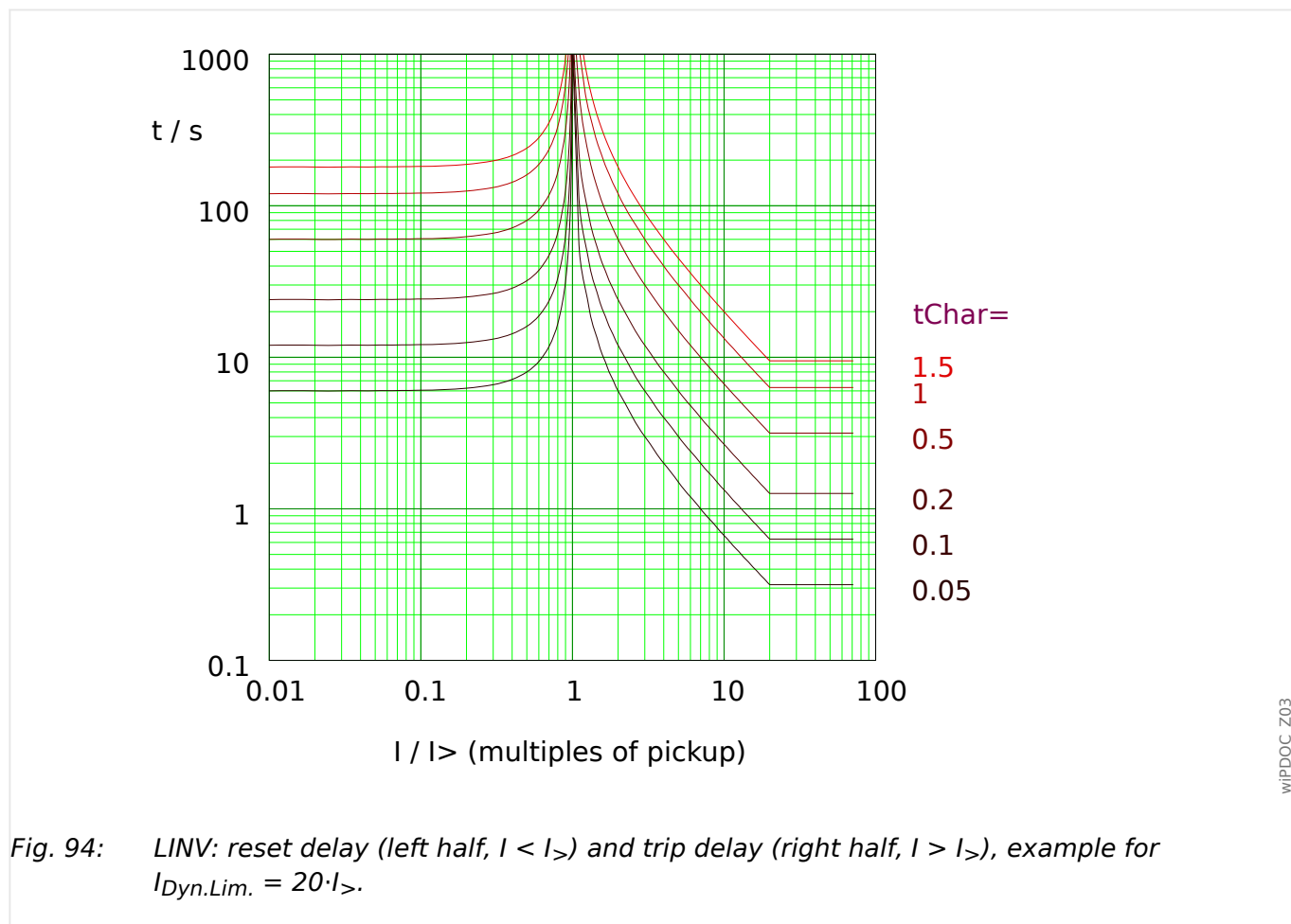

See [↳](#) “Explanation for All Characteristics ( $I_{>}$ ,  $I_{>>}$ ,  $I_{>>>}$ )” and [↳](#) “12.2.1.2 Inverse-Time Characteristics ( $I_{>}$ ,  $I_{>>}$ ,  $I_{>>>}$ )” for details.

**Reset Delay**

Various reset modes are available: Resetting [via characteristic](#), delayed and instantaneous.

**Trip Delay**

If  $I_{>} < I < I_{Dyn.Lim.}$ , the trip delay is defined [by the characteristic](#).

For  $I > I_{Dyn.Lim.}$ , the trip delay  $t$  is kept constant at  $t = t_{Dyn.Lim.}$ .

12.2.1.2.2 R Inverse [RINV] - Characteristic

»Char« = RINV

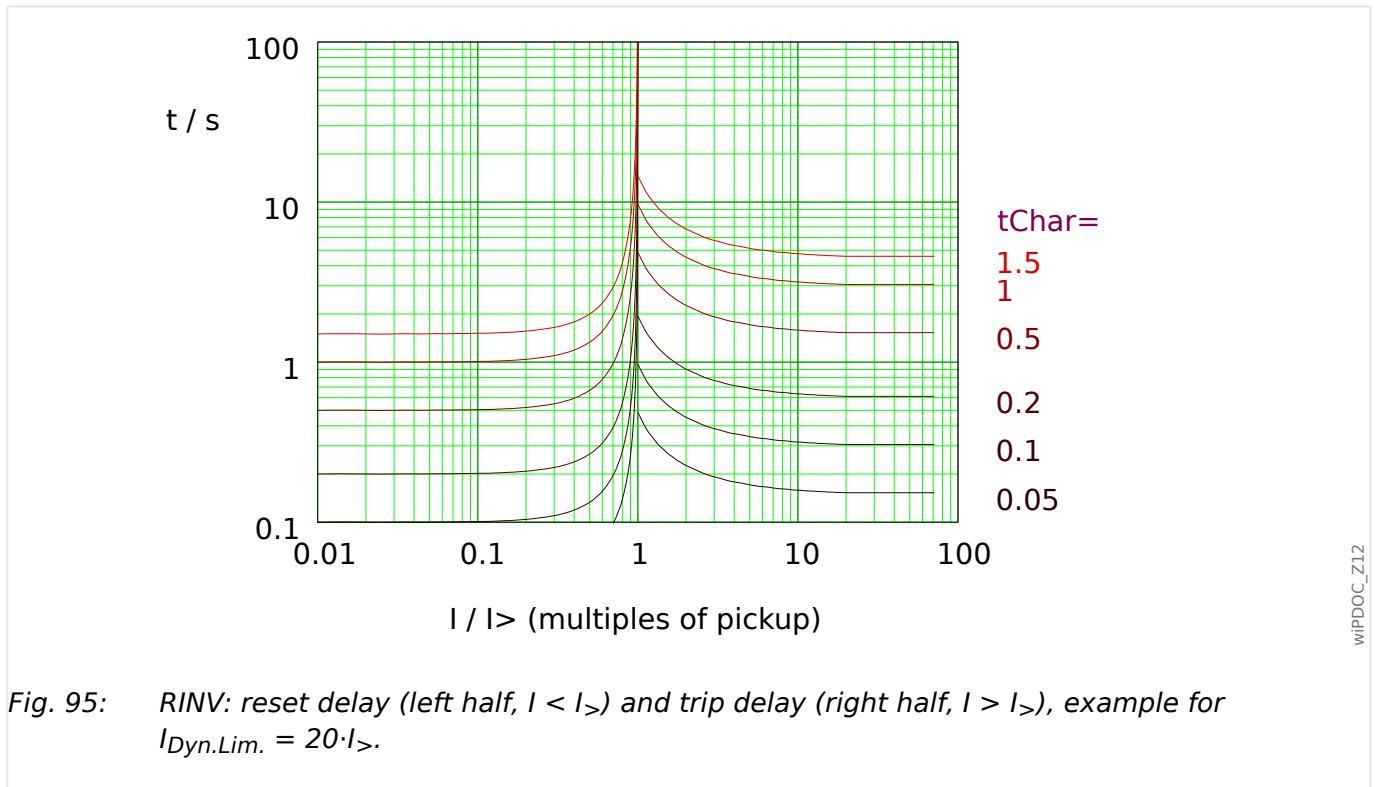

Fig. 95: RINV: reset delay (left half,  $I < I_{>}$ ) and trip delay (right half,  $I > I_{>}$ ), example for  $I_{Dyn.Lim.} = 20 \cdot I_{>}$ .

See [↳ “Explanation for All Characteristics \( \$I\_{>}\$ ,  \$I\_{>>}\$ ,  \$I\_{>>>}\$ \)”](#) and [↳ “12.2.1.2 Inverse-Time Characteristics \( \$I\_{>}\$ ,  \$I\_{>>}\$ ,  \$I\_{>>>}\$ \)”](#) for details.

**Reset Delay**

Various reset modes are available: Resetting [via characteristic](#), delayed and instantaneous.

**Trip Delay**

If  $I_{>} < I < I_{Dyn.Lim.}$ , the trip delay is defined [by the characteristic](#).

For  $I > I_{Dyn.Lim.}$ , the trip delay  $t$  is kept constant at  $t = t_{Dyn.Lim.}$ .

## 12.2.1.2.3 Fuse Characteristic of an HV Fuse - Phase Overcurrent Protection

»Char« = HV Fuse

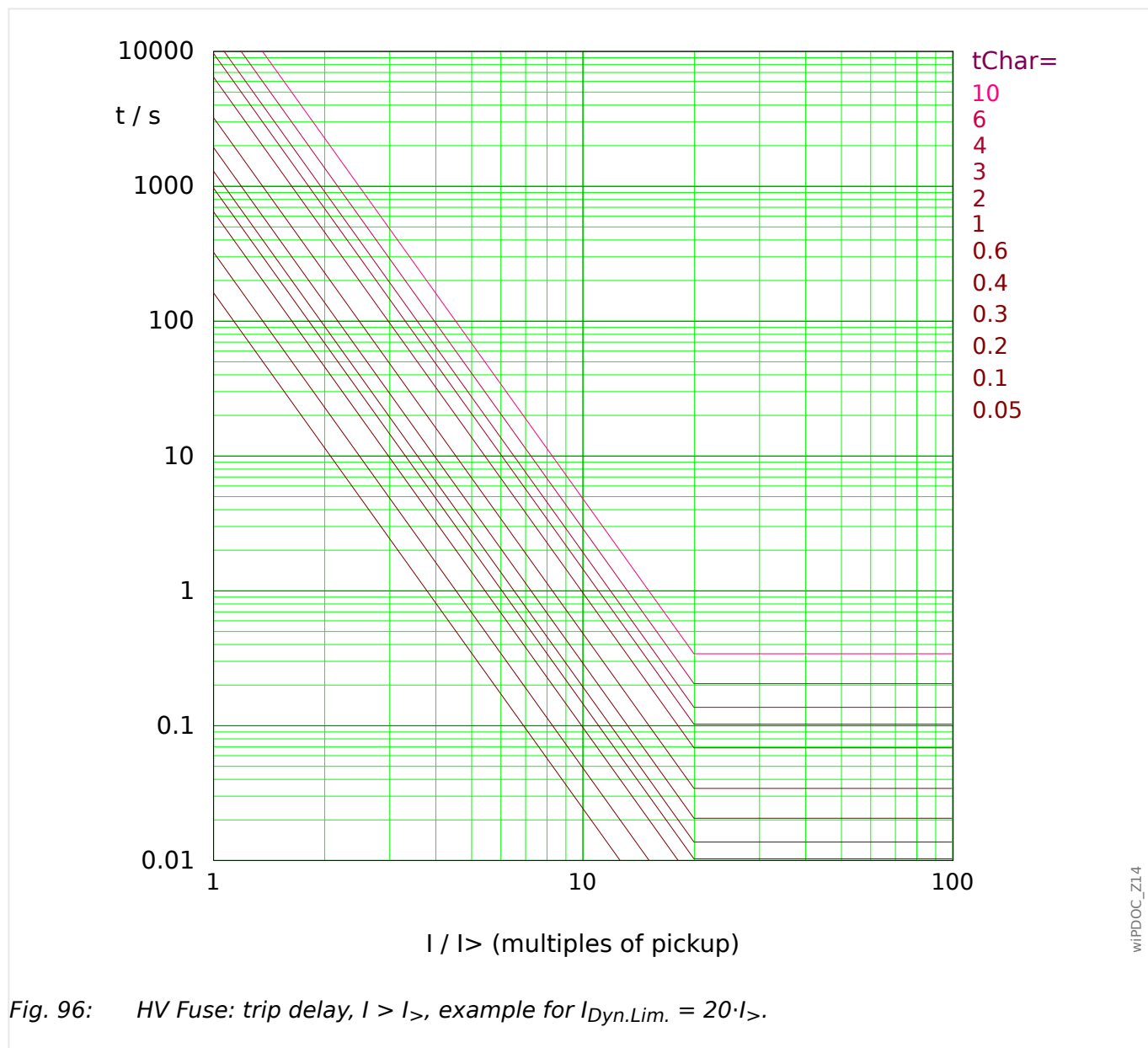

Fig. 96: HV Fuse: trip delay,  $I > I_{>}$ , example for  $I_{Dyn.Lim.} = 20 \cdot I_{>}$ .

See [↳ “Explanation for All Characteristics \( \$I\_{>}\$ ,  \$I\_{>>}\$ ,  \$I\_{>>>}\$ \)”](#) and [↳ “12.2.1.2 Inverse-Time Characteristics \( \$I\_{>}\$ ,  \$I\_{>>}\$ ,  \$I\_{>>>}\$ \)”](#) for details.

### Reset Delay

The reset modes “instantaneous” or “definite time” are available. For this characteristic, there is no reset mode with dynamic reset delay.

### Trip Delay

If  $I_{>} < I < I_{Dyn.Lim.}$ , the trip delay is defined by the characteristic.

For  $I > I_{Dyn.Lim.}$ , the trip delay  $t$  is kept constant at  $t = t_{Dyn.Lim.}$ .

12.2.1.2.4 Fuse Characteristic of a Full Range Fuse (FR-Fuse) - Phase Overcurrent Protection

»Char« = FR Fuse

Remark: This characteristic is sometimes also called the “Sweden curve”.

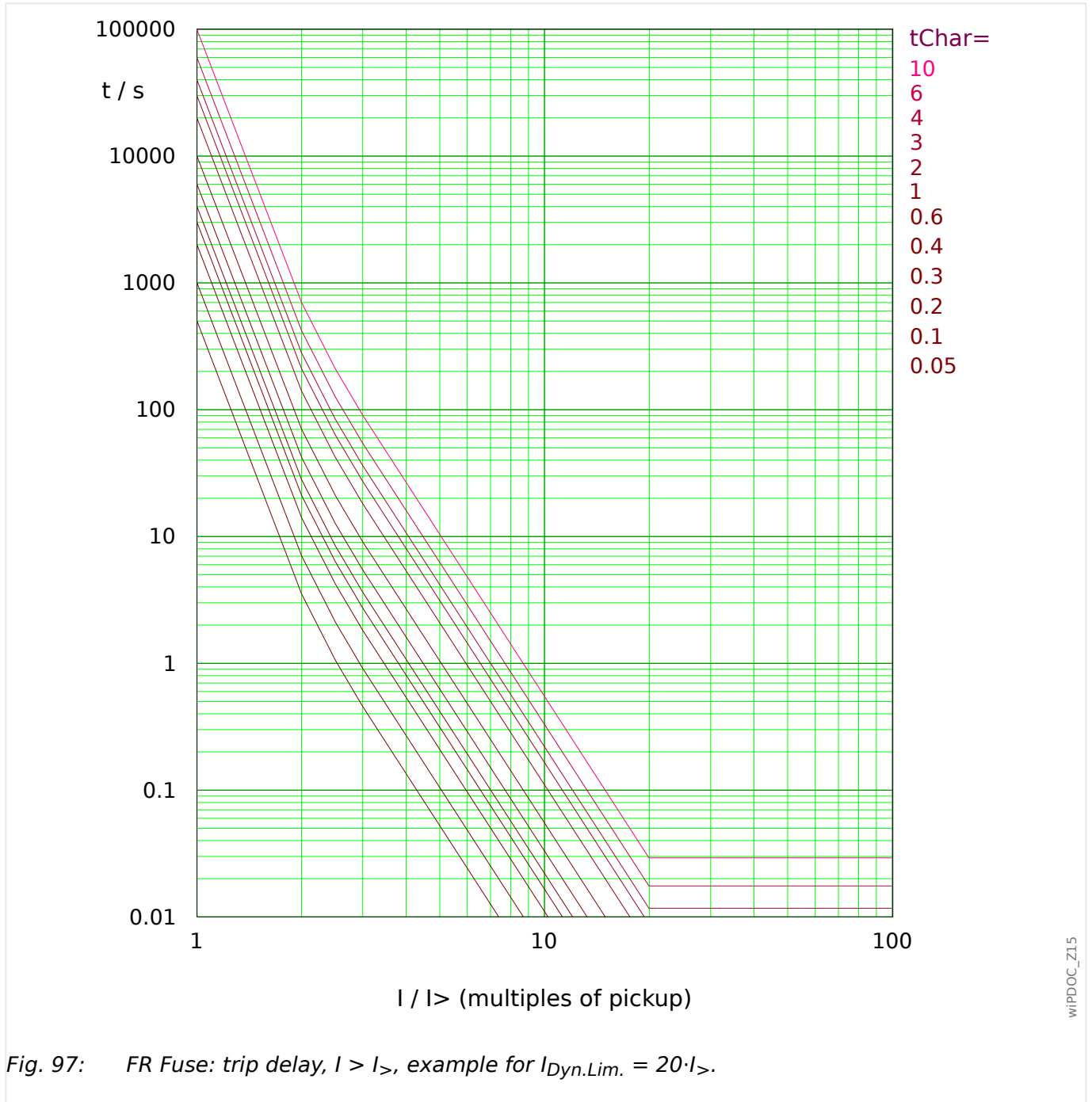

Fig. 97: FR Fuse: trip delay,  $I > I_{>}$ , example for  $I_{Dyn.Lim.} = 20 \cdot I_{>}$ .

See [“Explanation for All Characteristics \( \$I\_{>}\$ ,  \$I\_{>>}\$ ,  \$I\_{>>>}\$ \)”](#) and [“12.2.1.2 Inverse-Time Characteristics \( \$I\_{>}\$ ,  \$I\_{>>}\$ ,  \$I\_{>>>}\$ \)”](#) for details.

**Reset Delay**

The reset modes “instantaneous” or “definite time” are available. For this characteristic, there is no reset mode with dynamic reset delay.

**Trip Delay**

If  $I_{>} < I < I_{Dyn.Lim.}$ , the trip delay is defined by the characteristic.

For  $I > I_{Dyn.Lim.}$ , the trip delay  $t$  is kept constant at  $t = t_{Dyn.Lim.}$ .

»Char« = "IEEE MINV"

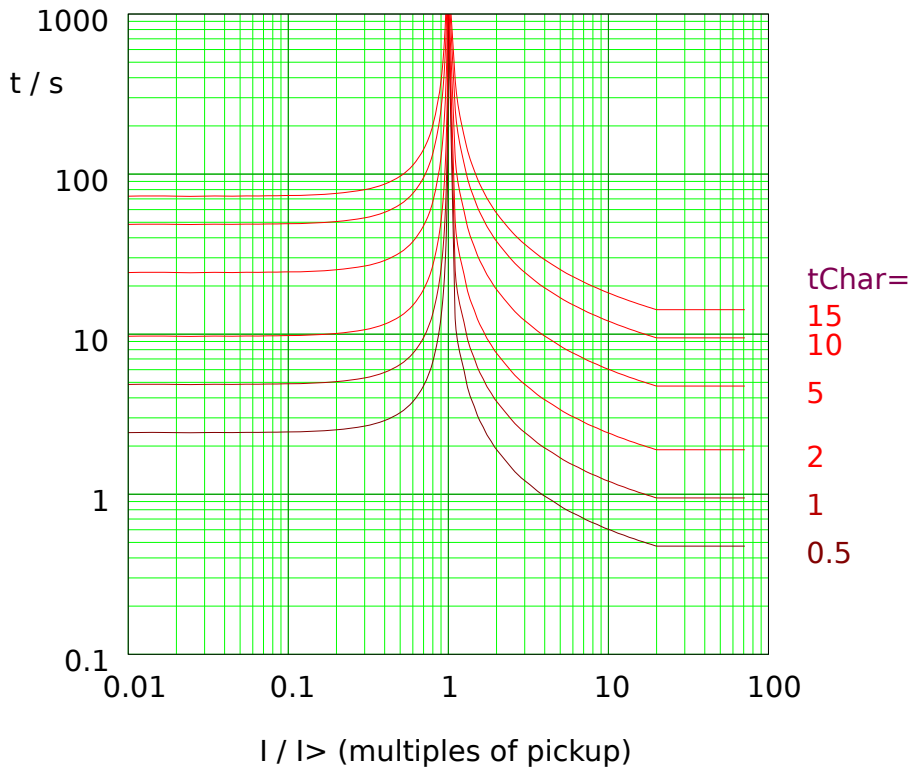

Fig. 98: MINV: reset delay (left half,  $I < I_{>}$ ) and trip delay (right half,  $I > I_{>}$ ), example for  $I_{Dyn.Lim.} = 20 \cdot I_{>}$ .

See [↳](#) "Explanation for All Characteristics (I>, I>>, I>>>)" and [↳](#) "12.2.1.2 Inverse-Time Characteristics (I>, I>>, I>>>)" for details.

**Reset Delay**

Various reset modes are available: Resetting [via characteristic](#), delayed and instantaneous.

**Trip Delay**

If  $I_{>} < I < I_{Dyn.Lim.}$ , the trip delay is defined [by the characteristic](#).

For  $I > I_{Dyn.Lim.}$ , the trip delay  $t$  is kept constant at  $t = t_{Dyn.Lim.}$ .



## 12.2.1.2.5.2 Very Inverse [VINV] (IEEE C37.112) – Phase Overcurrent Protection

»Char« = “IEEE VINV”

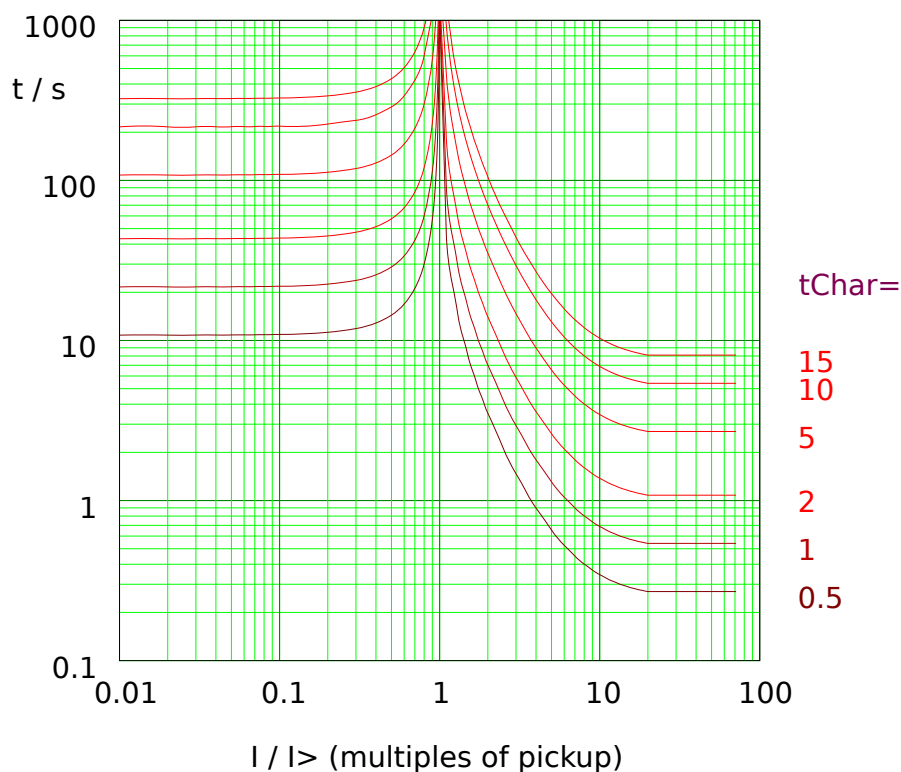

Fig. 99: VINV: reset delay (left half,  $I < I_{>}$ ) and trip delay (right half,  $I > I_{>}$ ), example for  $I_{Dyn.Lim.} = 20 \cdot I_{>}$ .

See [↳](#) “Explanation for All Characteristics ( $I_{>}$ ,  $I_{>>}$ ,  $I_{>>>}$ )” and [↳](#) “12.2.1.2 Inverse-Time Characteristics ( $I_{>}$ ,  $I_{>>}$ ,  $I_{>>>}$ )” for details.

### Reset Delay

Various reset modes are available: Resetting [via characteristic](#), delayed and instantaneous.

### Trip Delay

If  $I_{>} < I < I_{Dyn.Lim.}$ , the trip delay is defined [by the characteristic](#).

For  $I > I_{Dyn.Lim.}$ , the trip delay  $t$  is kept constant at  $t = t_{Dyn.Lim.}$ .

»Char« = "IEEE EINV"

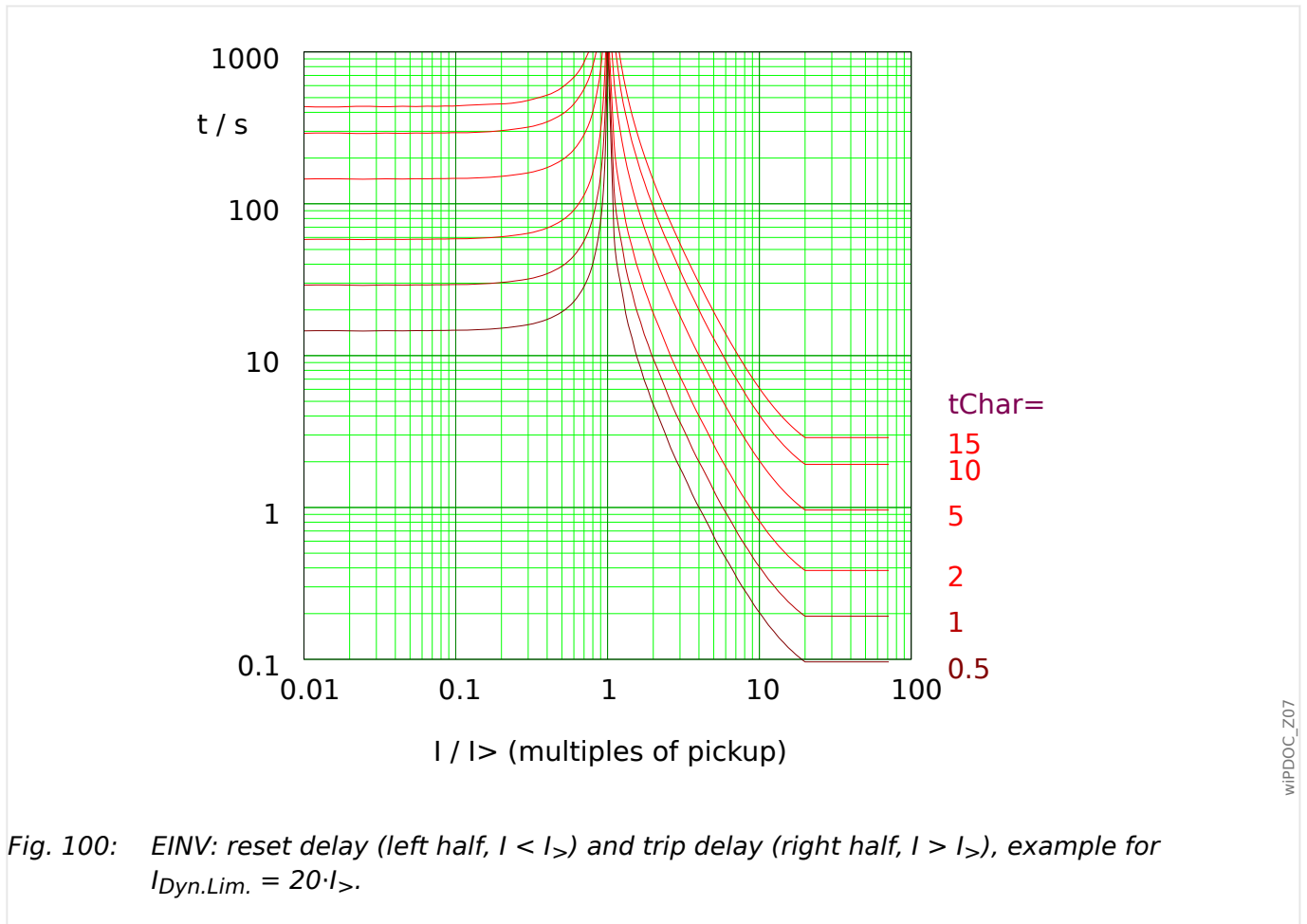

Fig. 100: EINV: reset delay (left half,  $I < I_{>}$ ) and trip delay (right half,  $I > I_{>}$ ), example for  $I_{Dyn.Lim.} = 20 \cdot I_{>}$ .

See [↳](#) "Explanation for All Characteristics ( $I_{>}$ ,  $I_{>>}$ ,  $I_{>>>}$ )" and [↳](#) "12.2.1.2 Inverse-Time Characteristics ( $I_{>}$ ,  $I_{>>}$ ,  $I_{>>>}$ )" for details.

**Reset Delay**

Various reset modes are available: Resetting [via characteristic](#), delayed and instantaneous.

**Trip Delay**

If  $I_{>} < I < I_{Dyn.Lim.}$ , the trip delay is defined [by the characteristic](#).

For  $I > I_{Dyn.Lim.}$ , the trip delay  $t$  is kept constant at  $t = t_{Dyn.Lim.}$ .

## 12.2.1.2.6 “EF” Curve – Phase Overcurrent Protection

»Char« = EF Curve

See  “Explanation for All Characteristics (I>, I>>, I>>>)” for details.

**Reset Delay**

The reset modes “instantaneous” or “definite time” are available. For this characteristic, there is no reset mode with dynamic reset delay.

**Trip Delay**

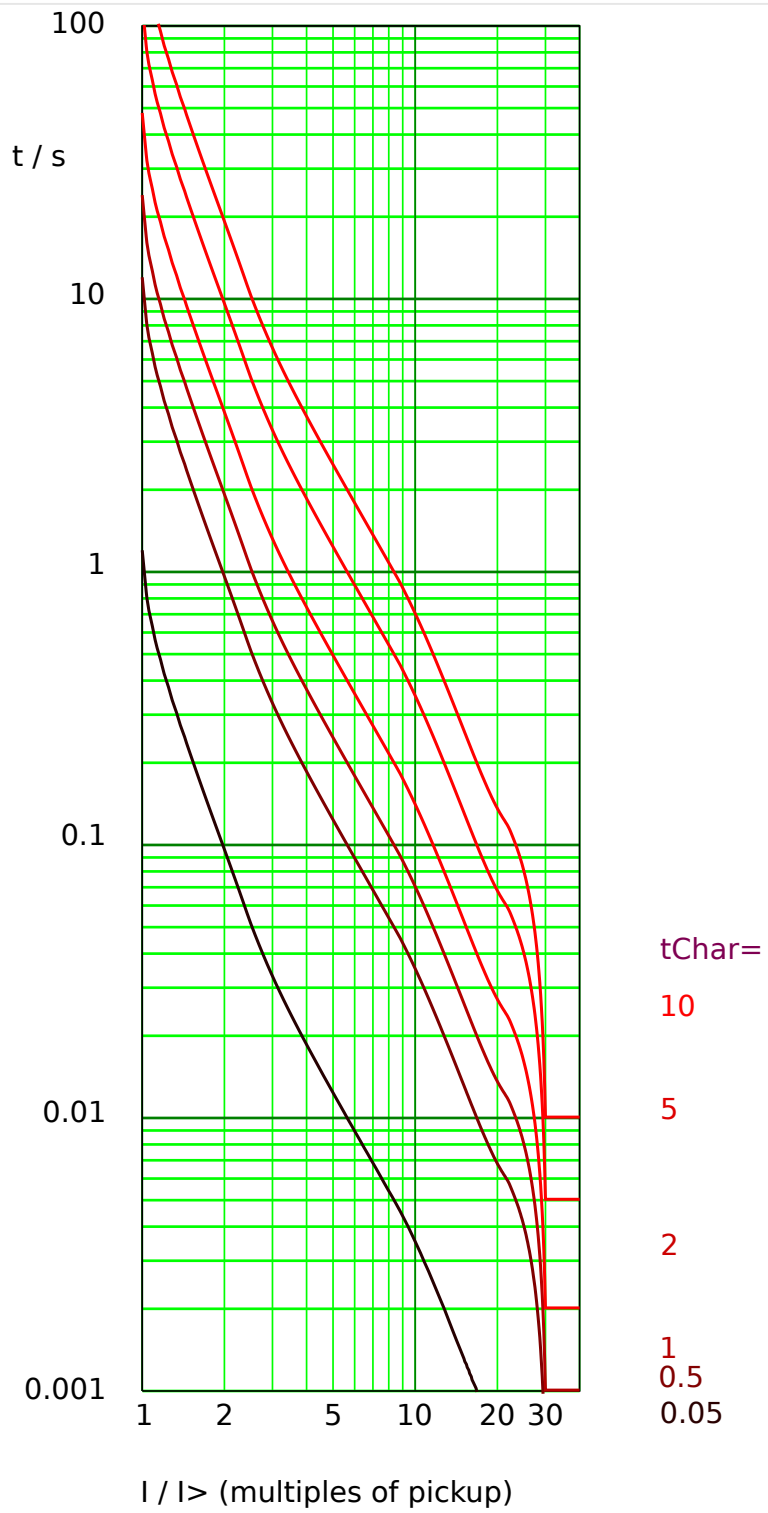

Fig. 101: EF Curve: trip delay,  $I > I_{>}$ , example for  $I_{Dyn.Lim.} = 30 \cdot I_{>}$ .

wIPDOC\_Z16

## 12.2.2 Characteristics (IG>, IG>>)

For each ground (earth) overcurrent stage the following characteristics are available:

- **DEFT** - *Definite Time-Overcurrent*
- **IEC 60255-151 Curves:**
  - **NINV** - *IEC Normal Inverse* (IEC 60255-151)
  - **VINV** - *IEC Very Inverse* (IEC 60255-151)
  - **LINV** - *IEC Long Time Inverse* (IEC 60255-151)
  - **EINV** - *IEC Extremely Inverse* (IEC 60255-151)
- **RINV** - *R Inverse*
- **HV Fuse** Fuse Characteristic of an HV Fuse
- **FR Fuse** Fuse Characteristic of a Full Range Fuse
- **Curves Defined in IEEE C37.112:**
  - **MINV** - *IEEE Moderately Inverse* (IEEE C37.112)
  - **VINV** - *IEEE Very Inverse* (IEEE C37.112)
  - **EINV** - *IEEE Extremely Inverse* (IEEE C37.112)
- **EF Curve** “EF” Curve
- **RXIDG**

### **Explanation for All Characteristics (IG>, IG>>)**

(Remark: All settings are given for protection stage »IG>«. »IG>>« has the same settings with corresponding menu branches.)

- **IG:** Pickup value for the protection stage. If the pickup value is exceeded, the stage starts to time out to trip.
- **IG> = I<sub>G></sub>:** If the pickup value is exceeded, the module/stage will be started.  
 Setting: [Protection Para / IG>] »IG«
- **Trip delay t for IG > I<sub>G></sub>:**
  - for »Char« = “**DEFT**”: settable via [Protection Para / IG>] »t«.
  - for all other characteristics: calculated based on the selected curve.
- **Reset mode for IG < I<sub>G></sub>,** settable via »Reset Mode«, available options:
  - With option »Reset Mode« = “instantaneous”: Instantaneous reset: when the current drops below the pickup setting, the TOC time resets to zero within 2 cycles.
  - With option »Reset Mode« = “definite time”: The reset delay is settable at »tReset«.

- With option »Reset Mode« = “inverse time” (only available for IEC and ANSI/IEEE curves): The reset delay is calculated based on the selected characteristics.
- tChar (for all characteristics except “DEFT”):
  - Time multiplier/tripping characteristic factor. The setting range depends on the selected tripping curve.
  - Setting via [Protection Para / IG>] »tChar«

For all inverse-time characteristics (i. e. all curves except the DEFT), there are two minimum trip delays, and independent of the selected characteristic will the actual trip delay never be smaller than any of these two minimum delays.

- »IG> . tMin« is a minimum delay settable by the user. So, this is simply a timer that is triggered independent of the inverse-time curve and that has to elapse before the protection stage trips. If it is set to 0 seconds it is deactivated. (See also [↪](#) “5.5.2.1 Earth (Ground) Overcurrent Protection – Settings via DiggiMEC or via Smart view”.)
- Another minimum delay,  $t_{Dyn.Lim.}$ , results from a calculated “knee-point” of the characteristic. This means it is dependent on a particular current value on the curve,  $I_{G,Dyn.Lim.}$ . The effective trip delay does never fall below  $t_{Dyn.Lim.}$ , independent of the actual value of IG.
  - $I_{G,Dyn.Lim.}$  is defined as the smallest value out of these three values:
    - $20 \cdot I_{G>}$  (EF Curve:  $30 \cdot I_{G>}$ ),
    - $20 \cdot I_{n,max}$ , if calculated ground/earth current  $IG_{calc}$  is used,
    - $20 \cdot I_{Gnom}$ , if measured ground/earth current  $IG_{meas}$  is used.
  - Then  $t_{Dyn.Lim.}$  is the delay time that is calculated from this  $I_{G,Dyn.Lim.}$  based on the selected characteristic.
  - (The diagram of each characteristic curve shows this “knee-point”, assuming the example value  $I_{G,Dyn.Lim.} = 20 \cdot I_{G>}$  [EF Curve:  $30 \cdot I_{G>}$ ].)
  - Exception: For »Char« = “RXIDG”,  $t_{Dyn.Lim.}$  is independent of  $I_{G,Dyn.Lim.}$ , but has the fixed value  $t_{Dyn.Lim.} = 0.02$  s

### 12.2.2.1 DEFT - Definite Time-Overcurrent ( $I_{G>}$ , $I_{G>>}$ )

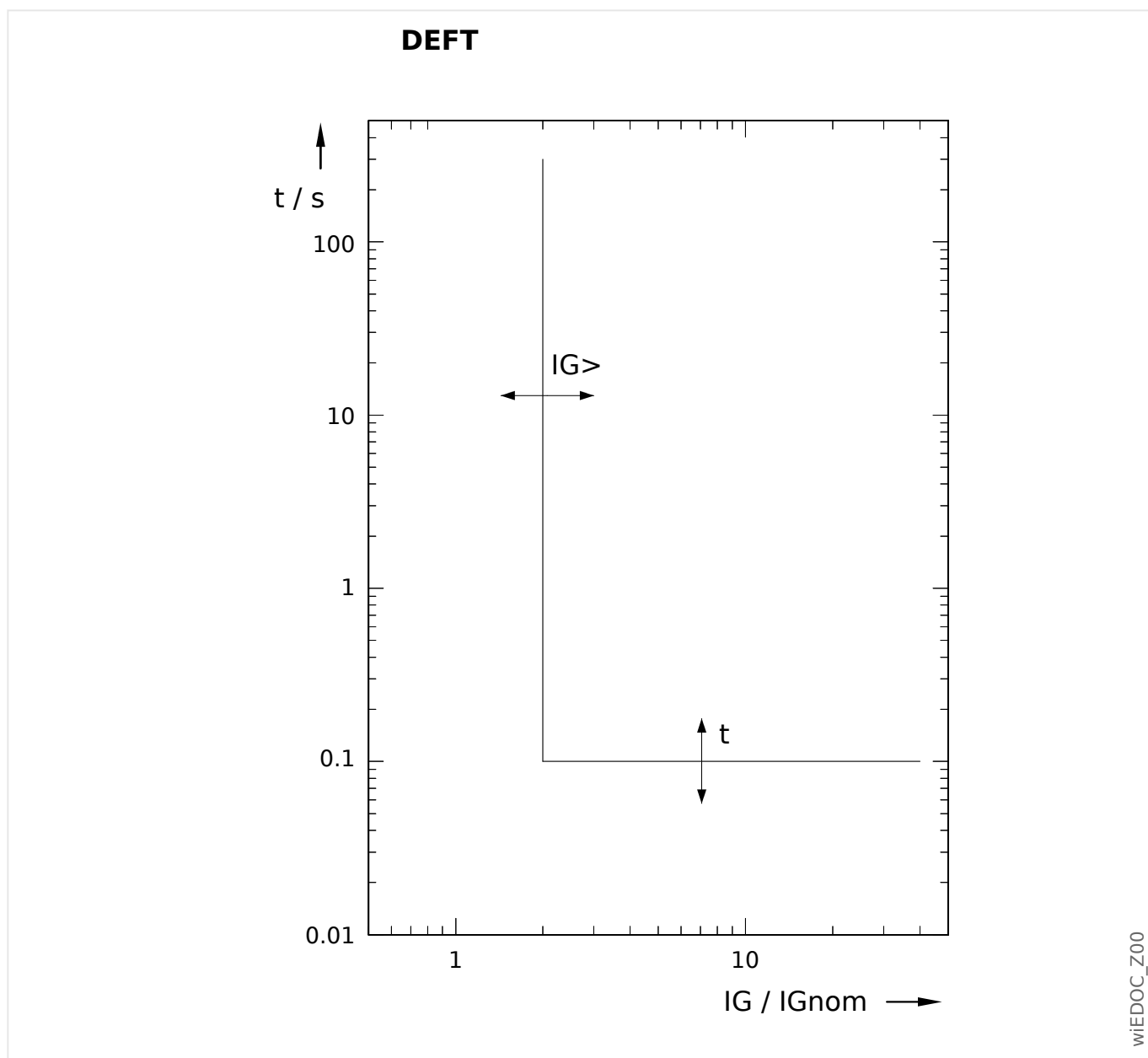

Trip delay for  $I_G > I_{G>}$ , settable via [Protection Para /  $I_{G>}$ ] »t«.

The reset delay for  $I_G < I_{G>}$  always equals 0 ("instantaneous").

**12.2.2.2 Inverse-Time Characteristics (IG>, IG>>)**

Characteristic »Char«	Trip Delay			Reset Delay (only for »Reset Mode« = "inverse time")	
	$t = \left( \frac{k}{\left(\frac{IG}{IG>}\right)^\alpha - 1} + c \right) \cdot tChar$			$t = \frac{\tau}{1 - \left(\frac{IG}{IG>}\right)^\alpha} \cdot tChar$	
	k [s]	c [s]	α	τ [s]	α
IEC NINV	0.14	0	0.02	0.14	2
IEC VINV	13.5	0	1	13.5	2
IEC EINV	80	0	2	80	2
IEC LINV	120	0	1	120	2
IEEE MINV	0.0515	0.1140	0.02	4.85	2
IEEE VINV	19.61	0.491	1	21.6	2
IEEE EINV	28.2	0.1217	2	29.1	2

Characteristic »Char«	Trip Delay			Reset Delay (only for »Reset Mode« = "inverse time")	
	$t = \frac{k}{b - \frac{c}{\left(\frac{IG}{IG>}\right)}} \cdot tChar$			$t = \frac{\tau}{1 - \left(\frac{IG}{IG>}\right)^\alpha} \cdot tChar$	
	k [s]	b	c	τ [s]	α
RINV	1.0	0.339	0.236	1.0	2



Characteristic »Char«		Trip Delay			
		$t = k \cdot t_{Char} \cdot 10^{\alpha \cdot \log(b \cdot \frac{IG}{IG>}) + c}$			
		k	b	c	$\alpha$
		[s]			
HV Fuse		10	2	3.66	-3.8320
FR Fuse	$1 < \frac{IG}{IG>} < 2$	10	1	3.0	-7.16
	$2 < \frac{IG}{IG>} < 2.66$	10	1	2.47	-5.4
	$2.66 < \frac{IG}{IG>} < \frac{I_{max}}{IG>}$	10	1	1.98	-4.24

Characteristic »Char«		Trip Delay	
		$t = m - k \cdot \ln\left(\frac{IG}{IG> \cdot t_{Char}}\right)$	
		k	m
		[s]	[s]
RXIDG		1.35	5.8

See [↪](#) “Explanation for All Characteristics (IG>, IG>>)” for more information.

»Char« = IEC NINV

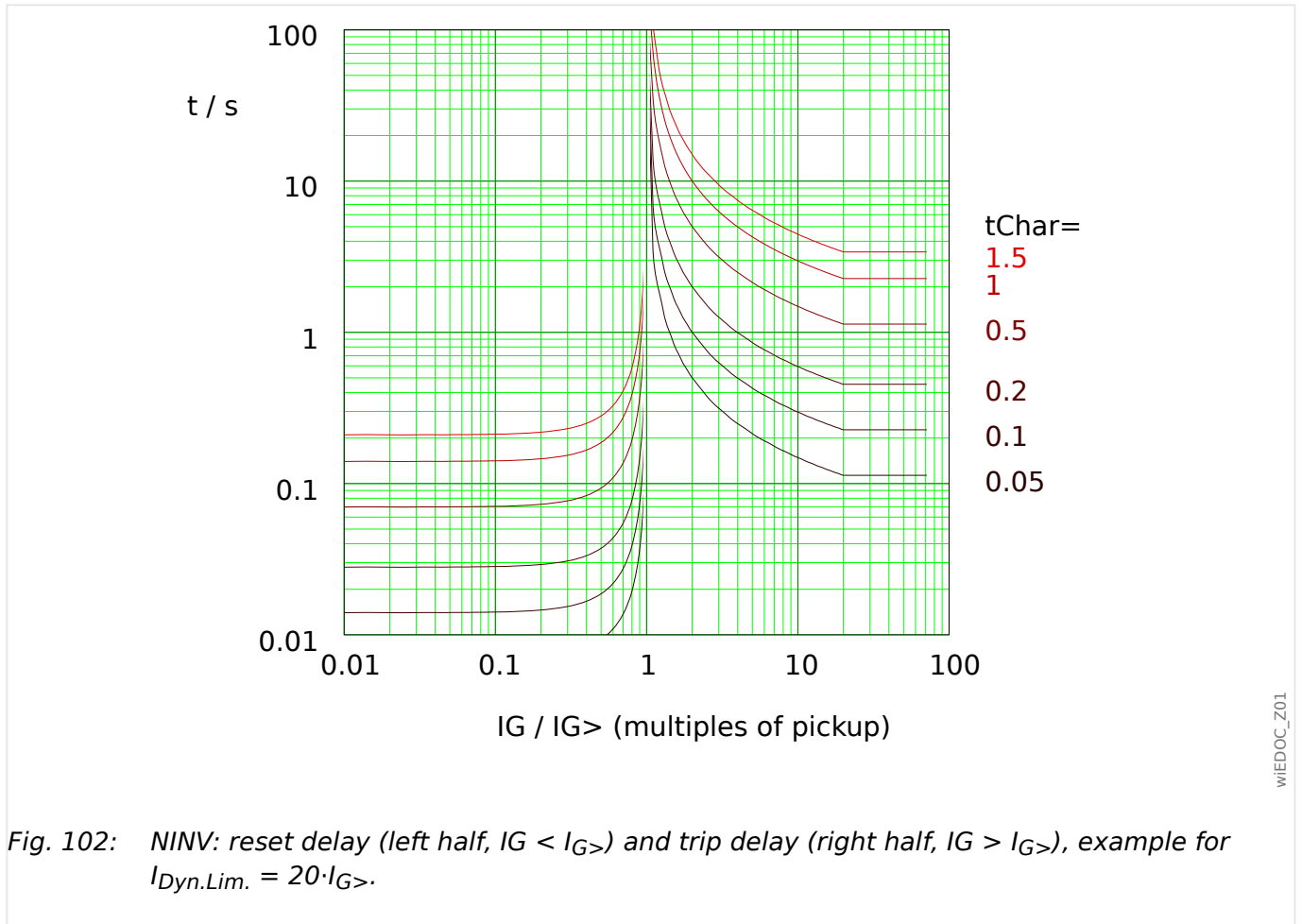

Fig. 102: NINV: reset delay (left half,  $I_G < I_{G>}$ ) and trip delay (right half,  $I_G > I_{G>}$ ), example for  $I_{Dyn.Lim.} = 20 \cdot I_{G>}$ .

See [↳ “Explanation for All Characteristics \(IG>, IG>>\)”](#) and [↳ “12.2.2.2 Inverse-Time Characteristics \(IG>, IG>>\)”](#) for details.

**Reset Delay**

Various reset modes are available: Resetting [via characteristic](#), delayed and instantaneous.

**Trip Delay**

If  $I_{G>} < I_G < I_{Dyn.Lim.}$ , the trip delay is defined [by the characteristic](#).

For  $I_G > I_{Dyn.Lim.}$ , the trip delay  $t$  is kept constant at  $t = t_{Dyn.Lim.}$ .

## 12.2.2.2.1.2 IEC Very Inverse [VINV] (IEC 60255-151)

»Char« = IEC VINV

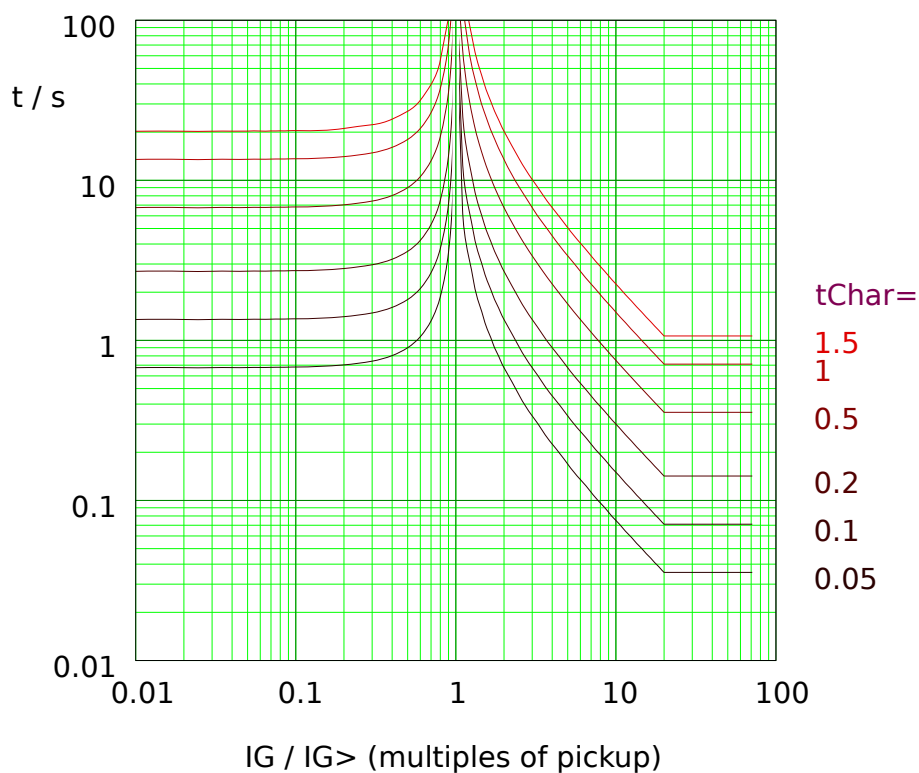

Fig. 103: VINV: reset delay (left half,  $I_G < I_{G>}$ ) and trip delay (right half,  $I_G > I_{G>}$ ), example for  $I_{Dyn.Lim.} = 20 \cdot I_{G>}$ .

See [↳](#) “Explanation for All Characteristics ( $I_{G>}$ ,  $I_{G>>}$ )” and [↳](#) “12.2.2.2 Inverse-Time Characteristics ( $I_{G>}$ ,  $I_{G>>}$ )” for details.

### Reset Delay

Various reset modes are available: Resetting [via characteristic](#), delayed and instantaneous.

### Trip Delay

If  $I_{G>} < I_G < I_{Dyn.Lim.}$ , the trip delay is defined [by the characteristic](#).

For  $I_G > I_{Dyn.Lim.}$ , the trip delay  $t$  is kept constant at  $t = t_{Dyn.Lim.}$ .

»Char« = IEC EINV

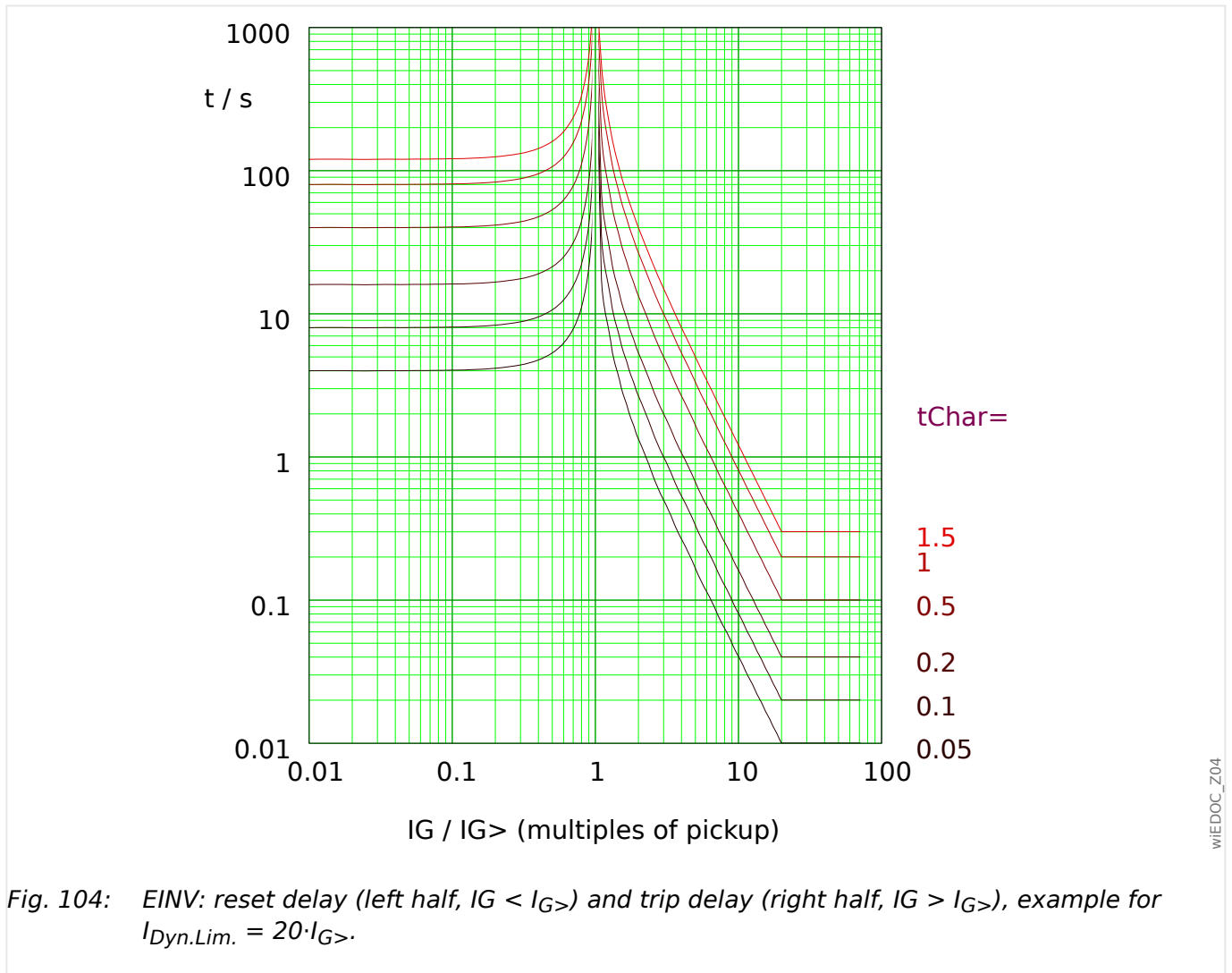

Fig. 104: EINV: reset delay (left half,  $I_G < I_{G>}$ ) and trip delay (right half,  $I_G > I_{G>}$ ), example for  $I_{Dyn.Lim.} = 20 \cdot I_{G>}$ .

See [↳](#) “Explanation for All Characteristics ( $I_{G>}$ ,  $I_{G>>}$ )” and [↳](#) “12.2.2.2 Inverse-Time Characteristics ( $I_{G>}$ ,  $I_{G>>}$ )” for details.

**Reset Delay**

Various reset modes are available: Resetting [via characteristic](#), delayed and instantaneous.

**Trip Delay**

If  $I_{G>} < I_G < I_{Dyn.Lim.}$ , the trip delay is defined [by the characteristic](#).

For  $I_G > I_{Dyn.Lim.}$ , the trip delay  $t$  is kept constant at  $t = t_{Dyn.Lim.}$ .

## 12.2.2.2.1.4 IEC Long Time Inverse - Characteristic [LINV] (IEC 60255-151)

»Char« = IEC LINV

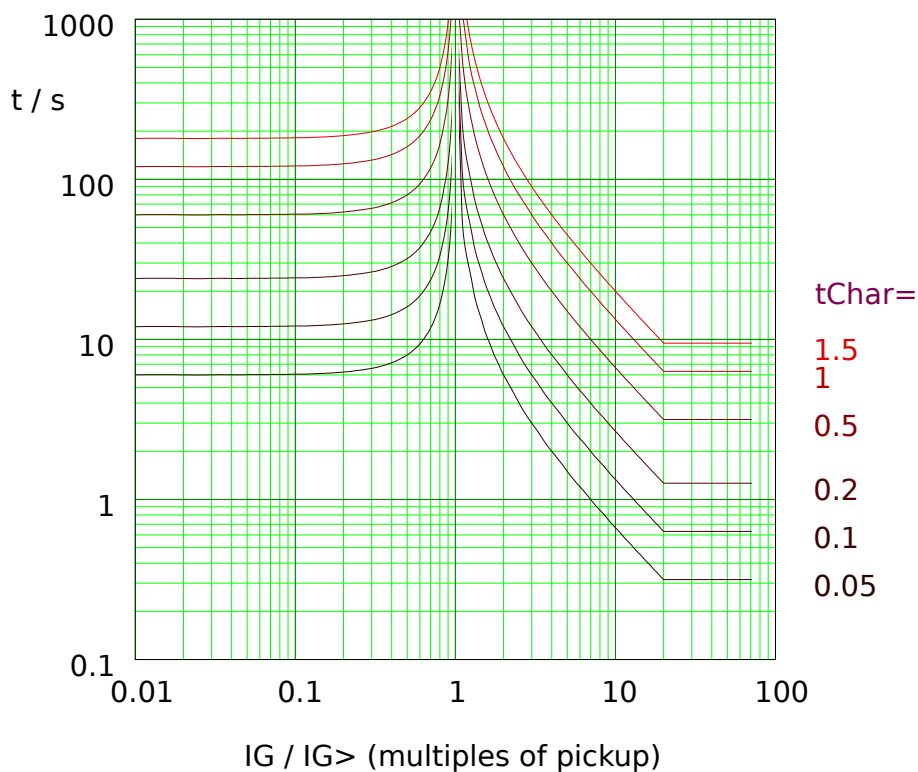

Fig. 105: LINV: reset delay (left half,  $I_G < I_{G>}$ ) and trip delay (right half,  $I_G > I_{G>}$ ), example for  $I_{Dyn.Lim.} = 20 \cdot I_{G>}$ .

See [↪](#) “Explanation for All Characteristics ( $I_{G>}$ ,  $I_{G>>}$ )” and [↪](#) “12.2.2.2 Inverse-Time Characteristics ( $I_{G>}$ ,  $I_{G>>}$ )” for details.

### Reset Delay

Various reset modes are available: Resetting [via characteristic](#), delayed and instantaneous.

### Trip Delay

If  $I_{G>} < I_G < I_{Dyn.Lim.}$ , the trip delay is defined [by the characteristic](#).

For  $I_G > I_{Dyn.Lim.}$ , the trip delay  $t$  is kept constant at  $t = t_{Dyn.Lim.}$ .

12.2.2.2.2 R Inverse [RINV] - Characteristic

»Char« = RINV

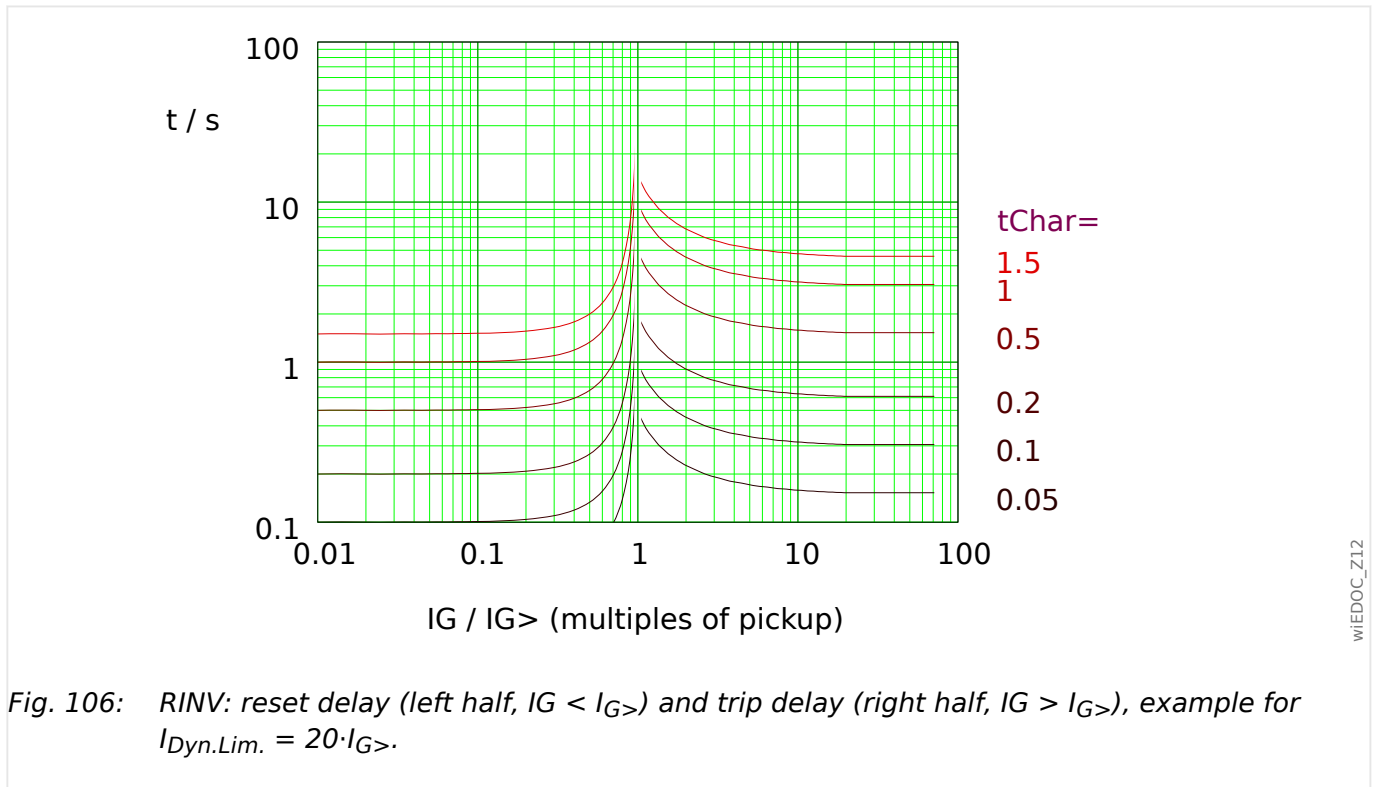

Fig. 106: RINV: reset delay (left half,  $I_G < I_{G>}$ ) and trip delay (right half,  $I_G > I_{G>}$ ), example for  $I_{Dyn.Lim.} = 20 \cdot I_{G>}$ .

See [↳ “Explanation for All Characteristics \(IG>, IG>>\)”](#) and [↳ “12.2.2.2 Inverse-Time Characteristics \(IG>, IG>>\)”](#) for details.

**Reset Delay**

Various reset modes are available: Resetting [via characteristic](#), delayed and instantaneous.

**Trip Delay**

If  $I_{G>} < I_G < I_{Dyn.Lim.}$ , the trip delay is defined [by the characteristic](#).

For  $I_G > I_{Dyn.Lim.}$ , the trip delay  $t$  is kept constant at  $t = t_{Dyn.Lim.}$ .

## 12.2.2.2.3 Fuse Characteristic of an HV Fuse

»Char« = HV Fuse

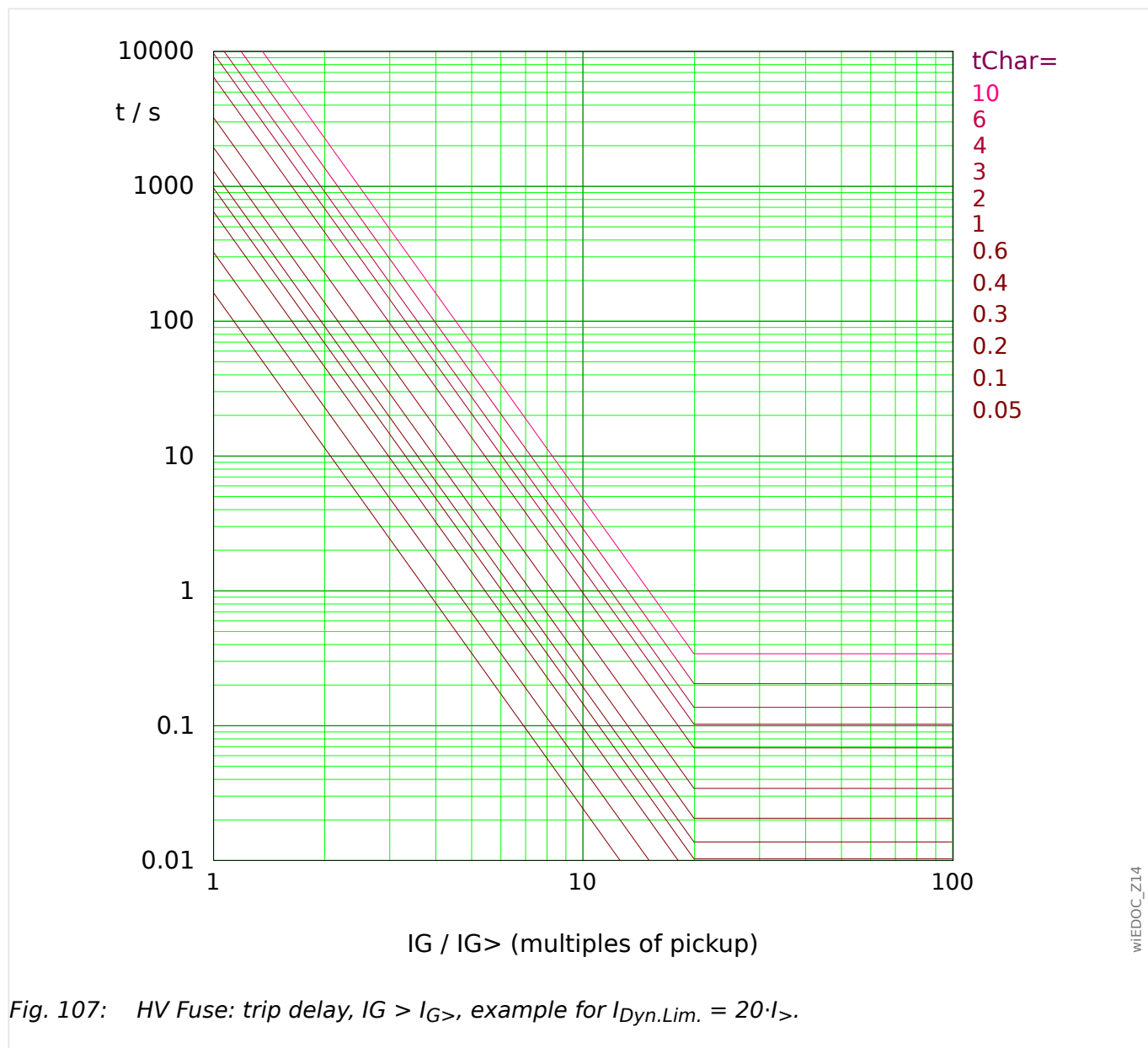

Fig. 107: HV Fuse: trip delay,  $I_G > I_{G>}$ , example for  $I_{Dyn.Lim.} = 20 \cdot I_{G>}$ .

See [“Explanation for All Characteristics \( \$I\_{G>}\$ ,  \$I\_{G>>}\$ \)”](#) and [“12.2.2.2 Inverse-Time Characteristics \( \$I\_{G>}\$ ,  \$I\_{G>>}\$ \)”](#) for details.

### Reset Delay

The reset modes “instantaneous” or “definite time” are available. For this characteristic, there is no reset mode with dynamic reset delay.

### Trip Delay

If  $I_{G>} < I_G < I_{Dyn.Lim.}$ , the trip delay is defined by the characteristic.

For  $I_G > I_{Dyn.Lim.}$ , the trip delay  $t$  is kept constant at  $t = t_{Dyn.Lim.}$ .

12.2.2.2.4 Fuse Characteristic of a Full Range Fuse (FR-Fuse)

»Char« = FR Fuse

Remark: This characteristic is sometimes also called the “Sweden curve”.

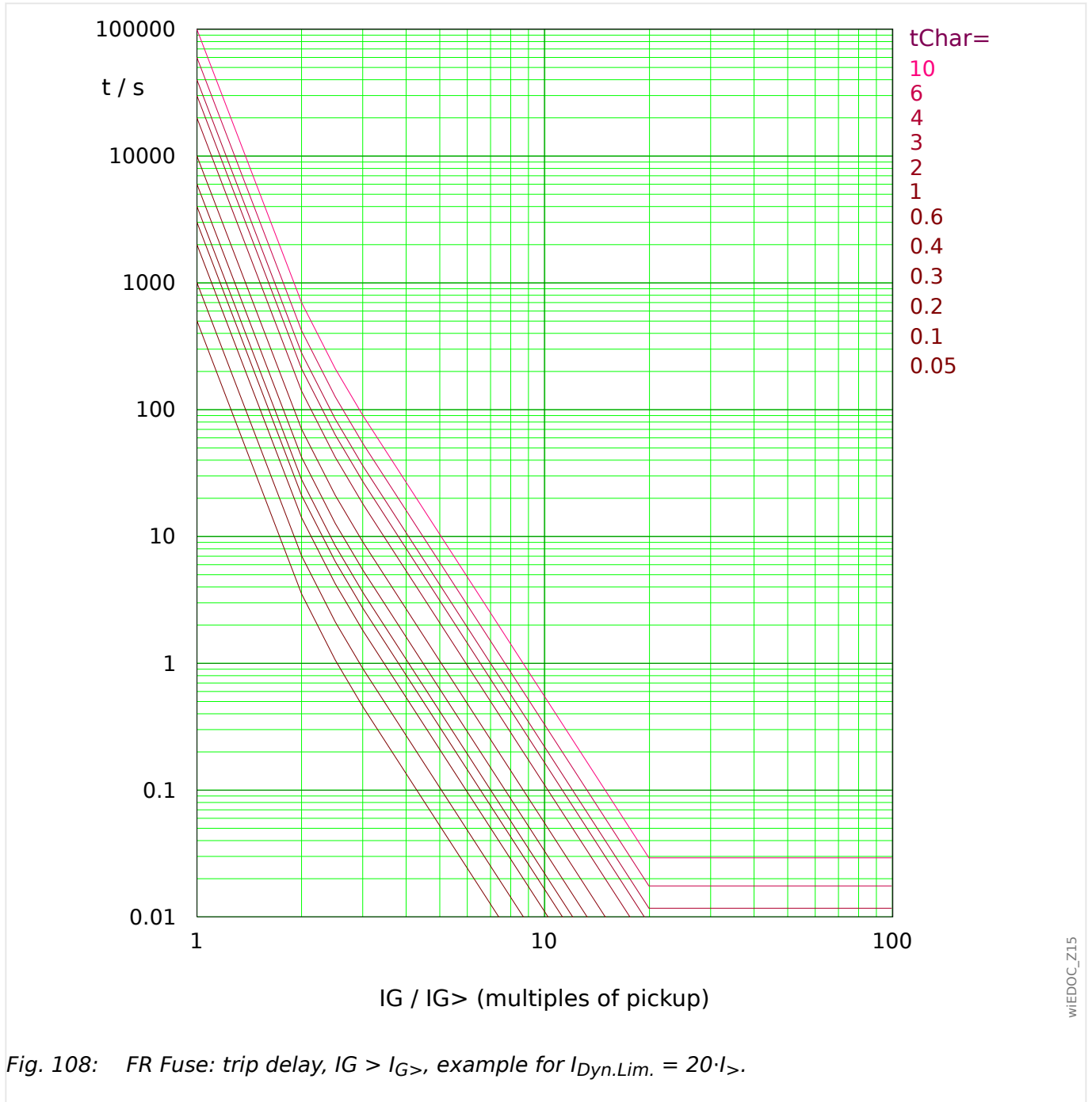

Fig. 108: FR Fuse: trip delay,  $I_G > I_{G>}$ , example for  $I_{Dyn.Lim.} = 20 \cdot I_{G>}$ .

See [↳ “Explanation for All Characteristics \( \$I\_{G>}\$ ,  \$I\_{G>>}\$ \)”](#) and [↳ “12.2.2.2 Inverse-Time Characteristics \( \$I\_{G>}\$ ,  \$I\_{G>>}\$ \)”](#) for details.

**Reset Delay**

The reset modes “instantaneous” or “definite time” are available. For this characteristic, there is no reset mode with dynamic reset delay.



**Trip Delay**

If  $I_{G>} < IG < I_{Dyn.Lim.}$ , the trip delay is defined [by the characteristic](#).

For  $IG > I_{Dyn.Lim.}$ , the trip delay  $t$  is kept constant at  $t = t_{Dyn.Lim.}$ .

12.2.2.2.5 IEEE C37.112 Curves (IG>, IG>>)

12.2.2.2.5.1 Moderately Inverse [MINV] - Characteristic (IEEE C37.112)

»Char« = "IEEE MINV"

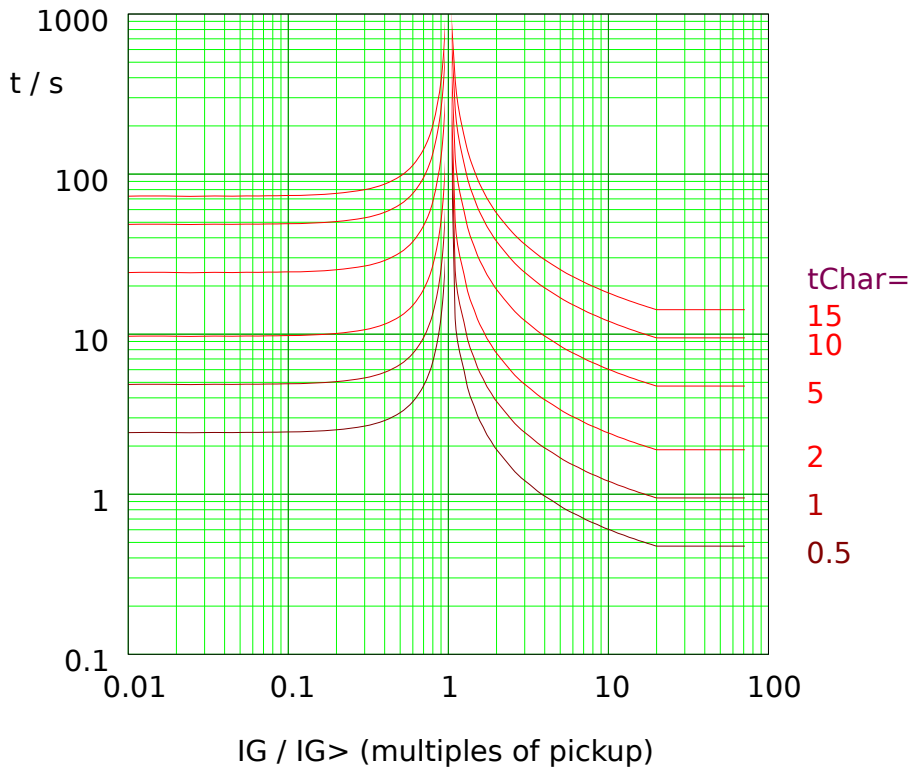

Fig. 109: MINV: reset delay (left half,  $I_G < I_{G>}$ ) and trip delay (right half,  $I_G > I_{G>}$ ), example for  $I_{Dyn.Lim.} = 20 \cdot I_{G>}$ .

See [↳](#) "Explanation for All Characteristics (IG>, IG>>)" and [↳](#) "12.2.2.2 Inverse-Time Characteristics (IG>, IG>>)" for details.

**Reset Delay**

Various reset modes are available: Resetting [via characteristic](#), delayed and instantaneous.

**Trip Delay**

If  $I_{G>} < I_G < I_{Dyn.Lim.}$ , the trip delay is defined [by the characteristic](#).

For  $I_G > I_{Dyn.Lim.}$ , the trip delay  $t$  is kept constant at  $t = t_{Dyn.Lim.}$ .

## 12.2.2.2.5.2 Very Inverse [VINV] (IEEE C37.112)

»Char« = "IEEE VINV"

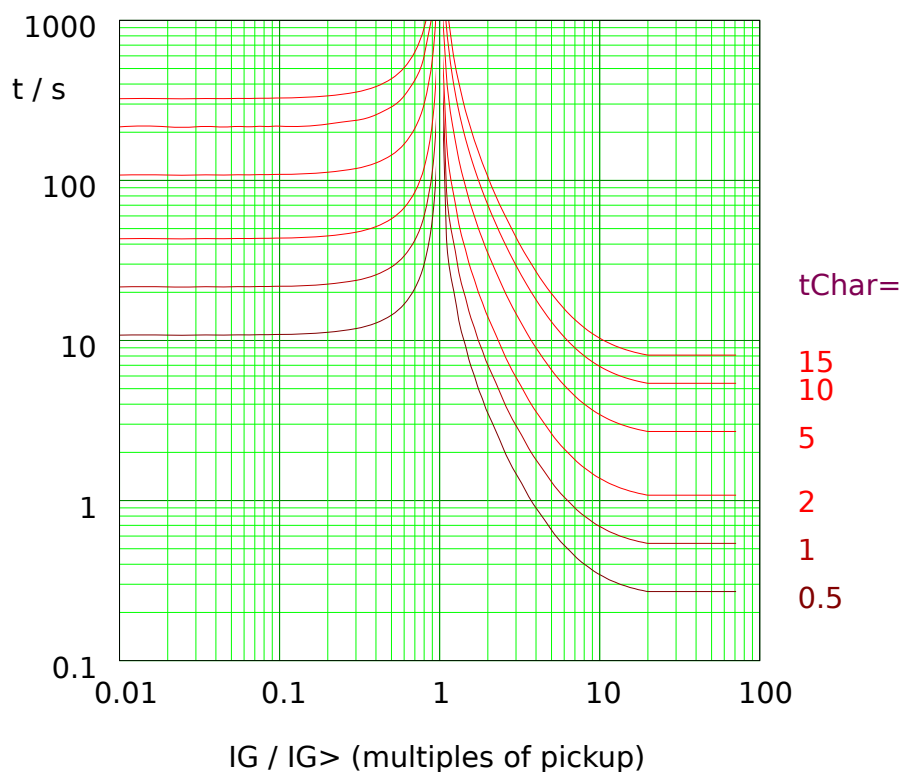

Fig. 110: VINV: reset delay (left half,  $I_G < I_{G>}$ ) and trip delay (right half,  $I_G > I_{G>}$ ), example for  $I_{Dyn.Lim.} = 20 \cdot I_{G>}$ .

See [↳](#) "Explanation for All Characteristics ( $I_{G>}$ ,  $I_{G>>}$ )" and [↳](#) "12.2.2.2 Inverse-Time Characteristics ( $I_{G>}$ ,  $I_{G>>}$ )" for details.

### Reset Delay

Various reset modes are available: Resetting [via characteristic](#), delayed and instantaneous.

### Trip Delay

If  $I_{G>} < I_G < I_{Dyn.Lim.}$ , the trip delay is defined [by the characteristic](#).

For  $I_G > I_{Dyn.Lim.}$ , the trip delay  $t$  is kept constant at  $t = t_{Dyn.Lim.}$ .

»Char« = "IEEE EINV"

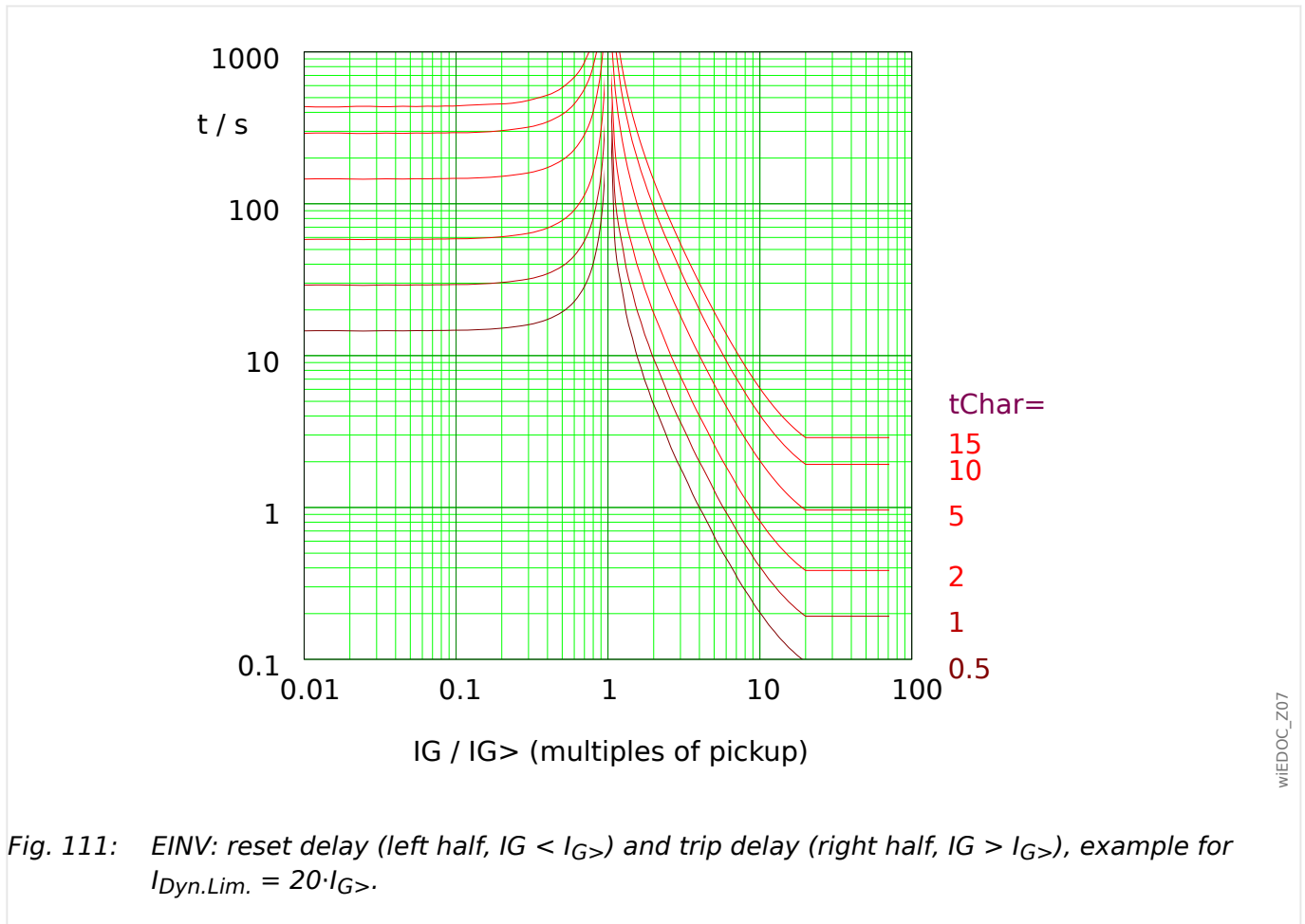

Fig. 111: EINV: reset delay (left half,  $I_G < I_{G>}$ ) and trip delay (right half,  $I_G > I_{G>}$ ), example for  $I_{Dyn.Lim.} = 20 \cdot I_{G>}$ .

See [↳ “Explanation for All Characteristics \( \$I\_{G>}\$ ,  \$I\_{G>>}\$ \)”](#) and [↳ “12.2.2.2 Inverse-Time Characteristics \( \$I\_{G>}\$ ,  \$I\_{G>>}\$ \)”](#) for details.

**Reset Delay**

Various reset modes are available: Resetting [via characteristic](#), delayed and instantaneous.

**Trip Delay**

If  $I_{G>} < I_G < I_{Dyn.Lim.}$ , the trip delay is defined [by the characteristic](#).

For  $I_G > I_{Dyn.Lim.}$ , the trip delay  $t$  is kept constant at  $t = t_{Dyn.Lim.}$ .

## 12.2.2.2.6 “EF” Curve

»Char« = EF Curve

See [↳ “Explanation for All Characteristics \(IG>, IG>>\)”](#) for details.

**Reset Delay**

The reset modes “instantaneous” or “definite time” are available. For this characteristic, there is no reset mode with dynamic reset delay.

**Trip Delay**

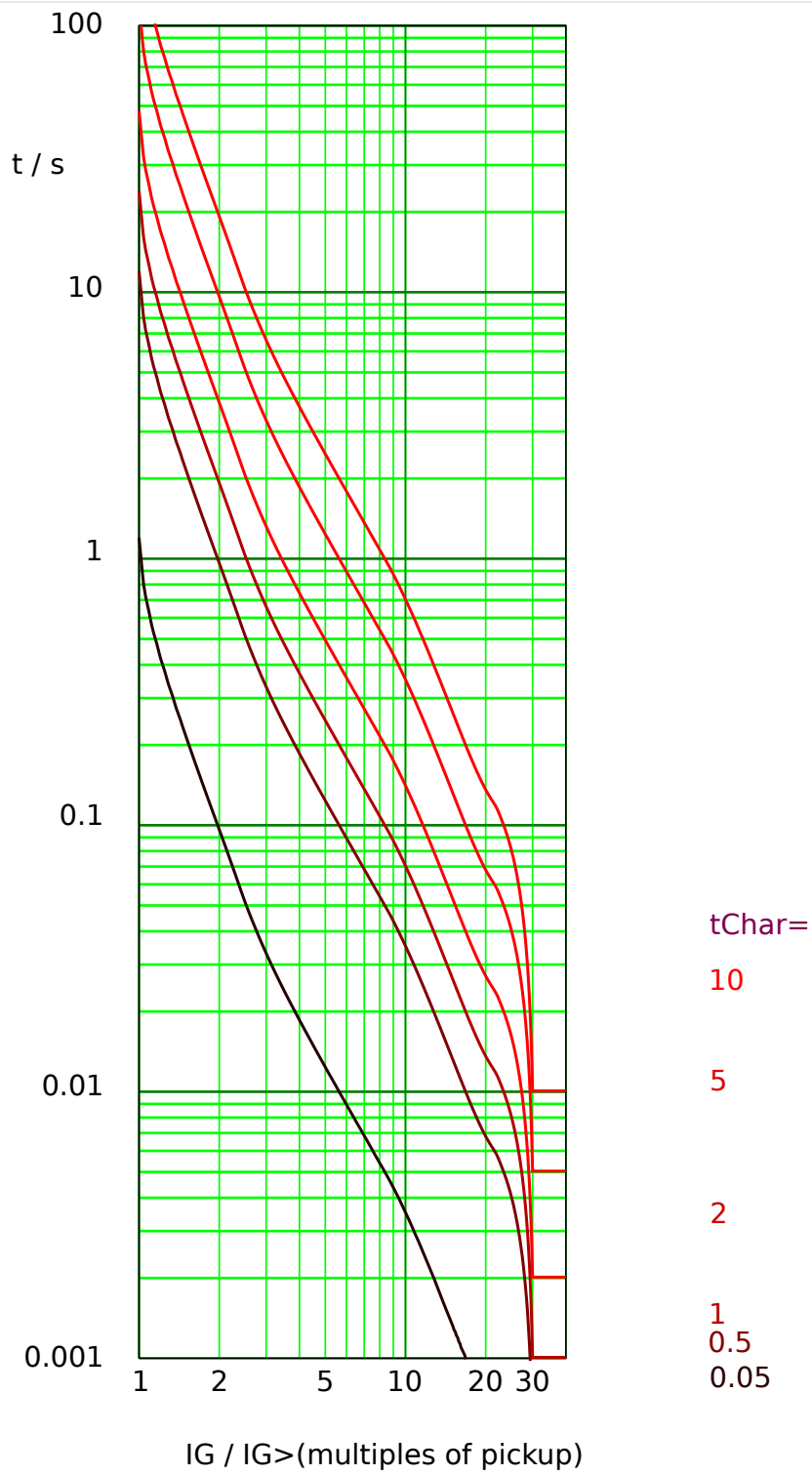

Fig. 112: EF Curve: trip delay,  $I_G > I_{G>}$ , example for  $I_{Dyn.Lim.} = 30 \cdot I_{G>}$ .

WIEDOC\_Z16

12.2.2.2.7 RXIDG

»Char« = RXIDG

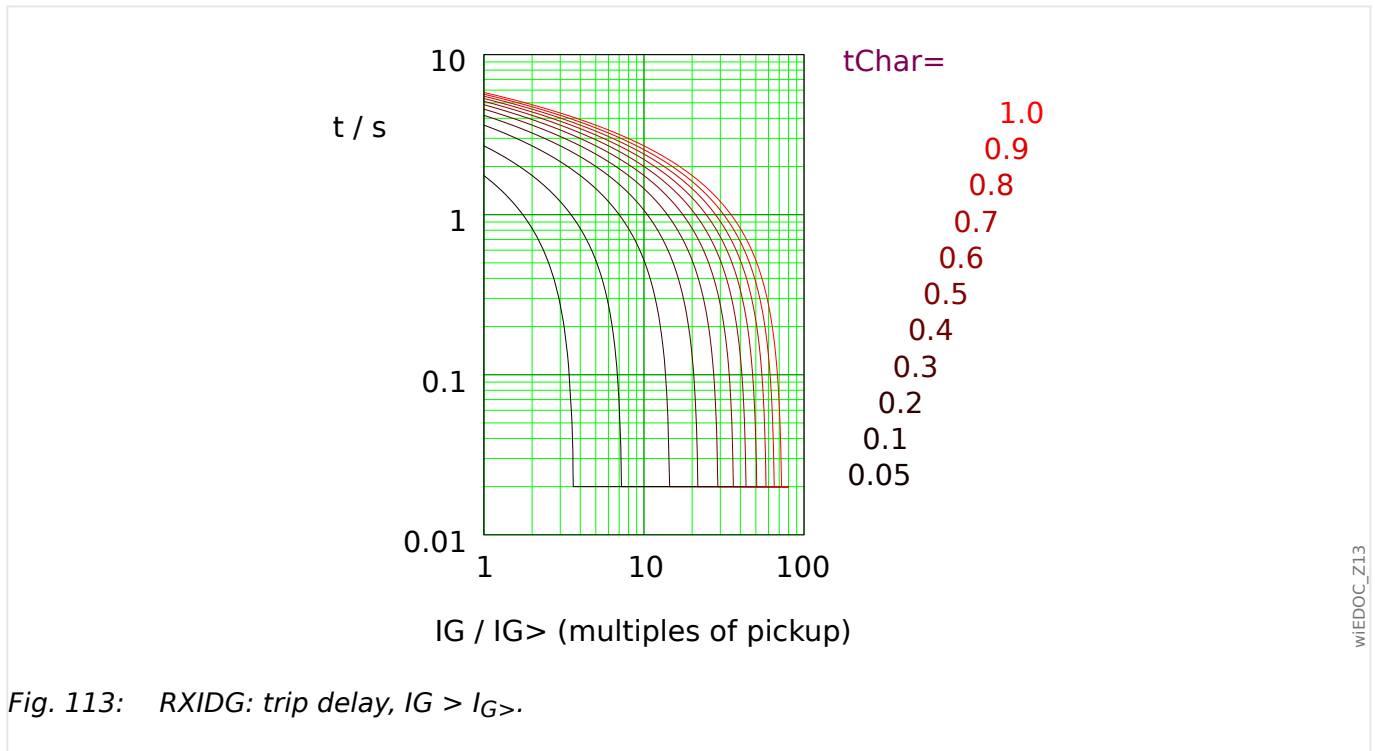

Fig. 113: RXIDG: trip delay,  $I_G > I_{G>}$ .

See [↳](#) “Explanation for All Characteristics ( $I_{G>}$ ,  $I_{G>>}$ )” and [↳](#) “12.2.2.2 Inverse-Time Characteristics ( $I_{G>}$ ,  $I_{G>>}$ )” for details.

**Reset Delay**

The reset modes “instantaneous” or “definite time” are available. For this characteristic, there is no reset mode with dynamic reset delay.

**Trip Delay**

If  $I_{G>} < I_G$ , the trip delay is defined by this equation, but only under the condition that the resulting trip delay holds  $t > t_{Dyn.Lim.}$  with  $t_{Dyn.Lim.} = 0.02$  s.

In other words, the trip delay  $t$  is always at least  $t_{Dyn.Lim.} = 0.02$  s.

### 12.2.3 Characteristics »I2>«

The following characteristics are available with the protection stage »I2>«:

- **DEFT** - *Definite Time-Overcurrent*
- **IEC 60255-151 Curves:**
  - **NINV** - *IEC Normal Inverse* (IEC 60255-151)
  - **VINV** - *IEC Very Inverse* (IEC 60255-151)
  - **LINV** - *IEC Long Time Inverse* (IEC 60255-151)
  - **EINV** - *IEC Extremely Inverse* (IEC 60255-151)
- **RINV** - *R Inverse*
- **HV Fuse** Fuse Characteristic of an HV Fuse
- **FR Fuse** Fuse Characteristic of a Full Range Fuse
- **Curves Defined in IEEE C37.112:**
  - **MINV** - *IEEE Moderately Inverse* (IEEE C37.112)
  - **VINV** - *IEEE Very Inverse* (IEEE C37.112)
  - **EINV** - *IEEE Extremely Inverse* (IEEE C37.112)
- **EF Curve** "EF" Curve

#### **Explanation for All Characteristics (»I2>«)**

- I2: Unbalanced load current
- I> = I2>: Pickup value for the protection stage. If the pickup value is exceeded, the stage starts to time out to trip.
- Setting: [Protection Para / I2>] »I2«
- Trip delay t for I2 > I2>:
  - for »Char« = "DEFT": settable via [Protection Para / I2>] »t«.
  - for all other characteristics: calculated based on the selected curve.
- Reset mode for I2 < I2>, settable via »Reset Mode«, available options:
  - With option »Reset Mode« = "instantaneous": Instantaneous reset: when the current drops below the pickup setting, the TOC time resets to zero within 2 cycles.
  - With option »Reset Mode« = "definite time": The reset delay is settable at »tReset«.
  - With option »Reset Mode« = "inverse time" (only available for IEC and ANSI/IEEE curves): The reset delay is calculated based on the selected characteristics.
- tChar (for all characteristics except "DEFT"):



- Time multiplier/tripping characteristic factor. The setting range depends on the selected tripping curve.
- Setting via [Protection Para / I2>] »tChar«

For all inverse-time characteristics (i. e. all curves except the **DEFT**), there are two minimum trip delays, and independent of the selected characteristic will the actual trip delay never be smaller than any of these two minimum delays.

- »I2> . tMin« is a minimum delay settable by the user. So, this is simply a timer that is triggered independent of the inverse-time curve and that has to elapse before the protection stage trips. If it is set to 0 seconds it is deactivated. (See also [↳ “5.6.2 Current Unbalance Protection – Settings via DiggiMEC or via Smart view”](#).)
- Another minimum delay,  $t_{Dyn.Lim.}$ , results from a calculated “knee-point” of the characteristic. This means it is dependent on a particular current value on the curve,  $I_{Dyn.Lim.}$ . The effective trip delay does never fall below  $t_{Dyn.Lim.}$ , independent of the actual value of  $I_2$ .
  - $I_{Dyn.Lim.}$  is defined as the smallest value out of  $20 \cdot I_n$  and  $20 \cdot I_{2>}$  (**EF Curve:  $30 \cdot I_{2>}$** ).
  - Then  $t_{Dyn.Lim.}$  is the delay time that is calculated from this  $I_{Dyn.Lim.}$  based on the selected characteristic.
  - (The diagram of each characteristic curve shows this “knee-point”, assuming the example value  $I_{Dyn.Lim.} = 20 \cdot I_{2>}$  [**EF Curve:  $30 \cdot I_{2>}$** ].)

**12.2.3.1 DEFT - Definite Time-Overcurrent ( $I_2 >$ )**

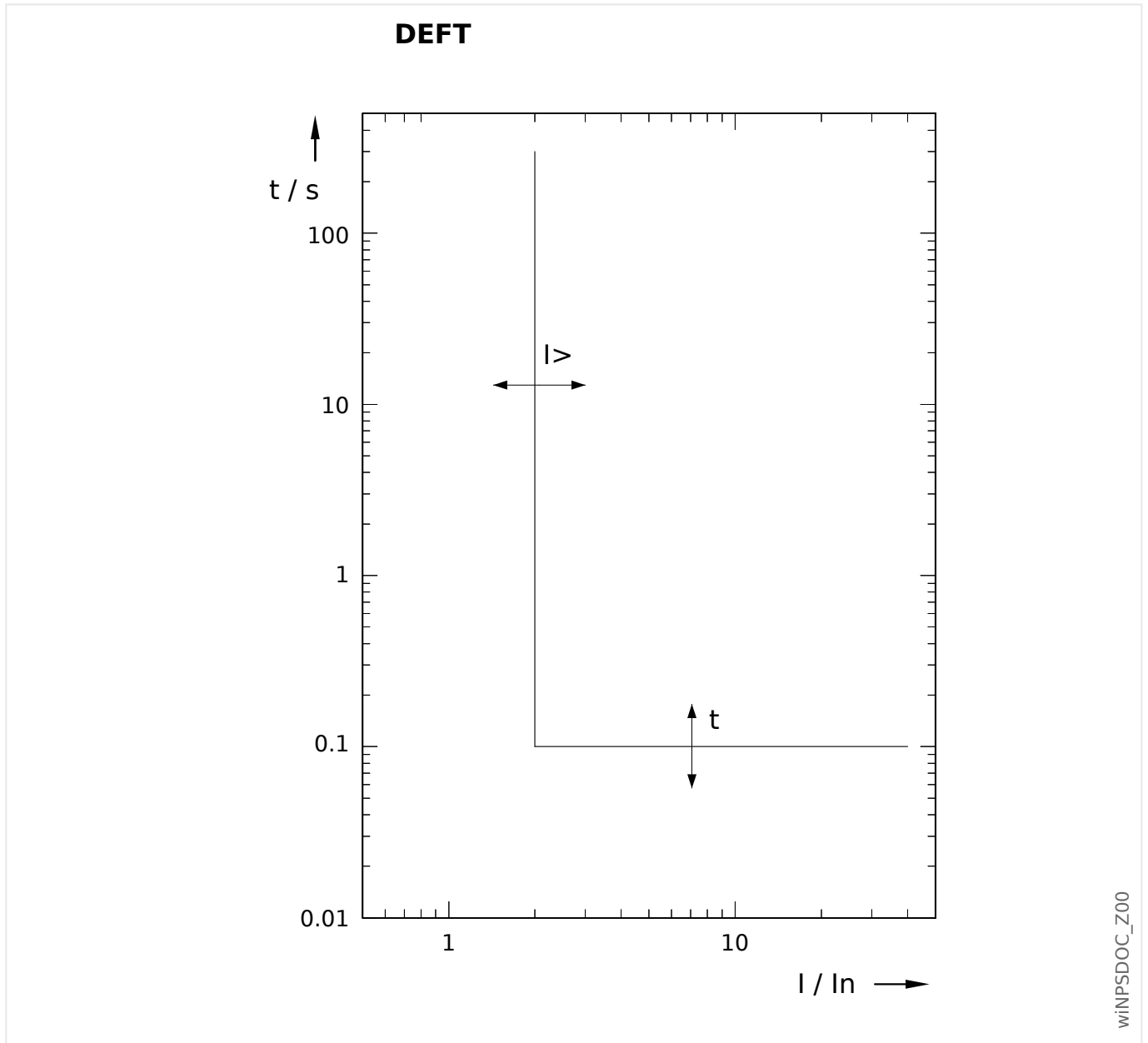

Trip delay for  $I_2 > I_{2>}$ , settable via [Protection Para /  $I_2 >$ ] »t«.

The reset delay for  $I_2 < I_{2>}$  always equals 0 ("instantaneous").

## 12.2.3.2 Inverse-Time Characteristics (»I2&gt;«)

Characteristic »Char«	Trip Delay			Reset Delay (only for »Reset Mode« = "inverse time")	
	$t = \left( \frac{k}{\left(\frac{I2}{I>}\right)^\alpha - 1} + c \right) \cdot tChar$			$t = \frac{\tau}{1 - \left(\frac{I2}{I>}\right)^\alpha} \cdot tChar$	
	k [s]	c [s]	$\alpha$	$\tau$ [s]	$\alpha$
IEC NINV	0.14	0	0.02	0.14	2
IEC VINV	13.5	0	1	13.5	2
IEC EINV	80	0	2	80	2
IEC LINV	120	0	1	120	2
IEEE MINV	0.0515	0.1140	0.02	4.85	2
IEEE VINV	19.61	0.491	1	21.6	2
IEEE EINV	28.2	0.1217	2	29.1	2

Characteristic »Char«	Trip Delay			Reset Delay (only for »Reset Mode« = "inverse time")	
	$t = \frac{k}{b - \frac{c}{\left(\frac{I2}{I>}\right)}} \cdot tChar$			$t = \frac{\tau}{1 - \left(\frac{I2}{I>}\right)^\alpha} \cdot tChar$	
	k [s]	b	c	$\tau$ [s]	$\alpha$
RINV	1.0	0.339	0.236	1.0	2

Characteristic »Char«		Trip Delay			
		$t = k \cdot t_{Char} \cdot 10^{\alpha \cdot \log(b \cdot \frac{I2}{I2}) + c}$			
		k [s]	b	c	α
HV Fuse		10	2	3.66	-3.8320
FR Fuse	$1 < \frac{I2}{I2} < 2$	10	1	3.0	-7.16
	$2 < \frac{I2}{I2} < 2.66$	10	1	2.47	-5.4
	$2.66 < \frac{I2}{I2} < \frac{I_{max}}{I2}$	10	1	1.98	-4.24

See [↪](#) “Explanation for All Characteristics (»I2>«)” for more information.

## 12.2.3.2.1 IEC 60255-151 Curves (»I2&gt;«)

## 12.2.3.2.1.1 Normal Inverse (IEC 60255-151)

»Char« = IEC NINV

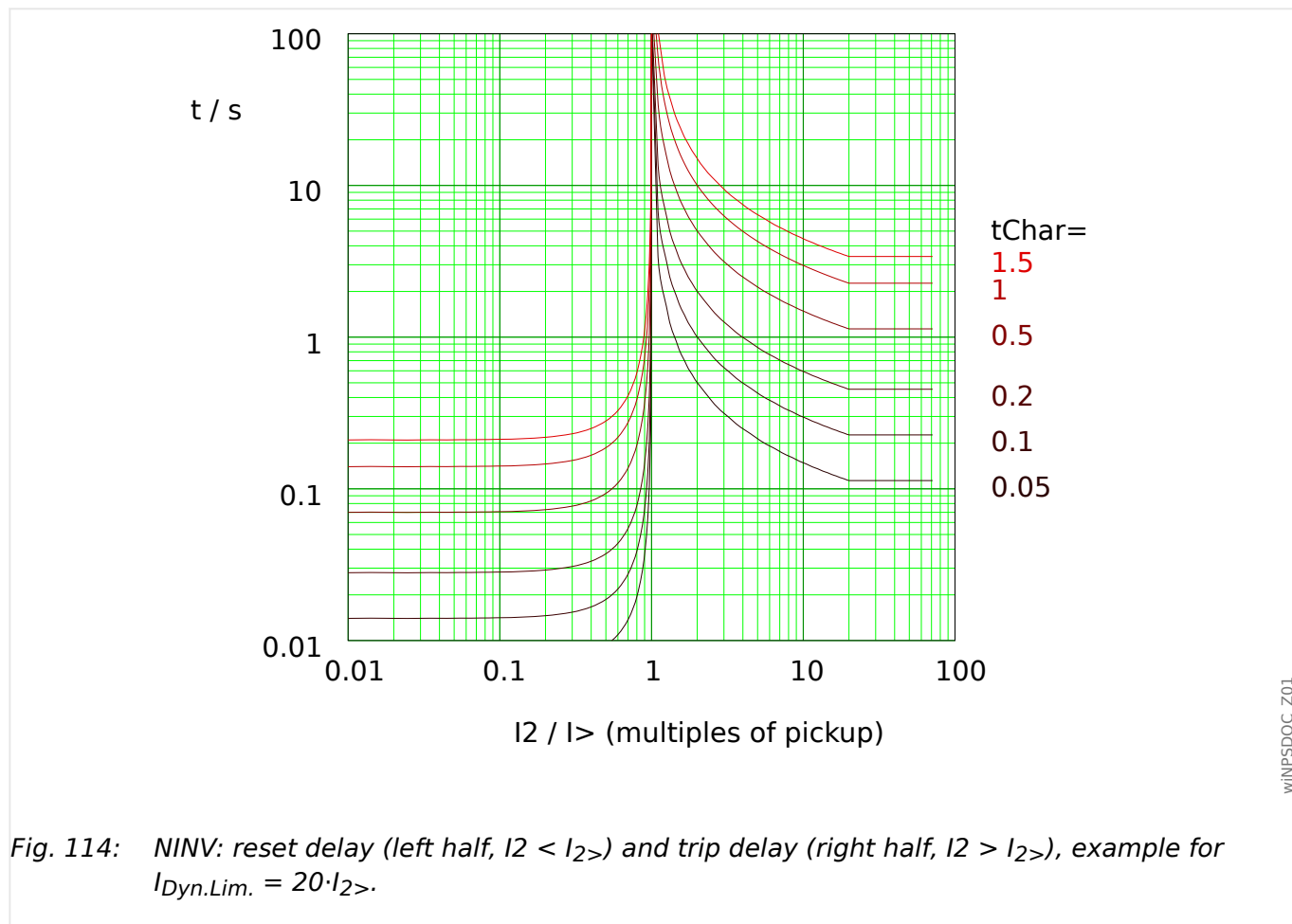

Fig. 114: NINV: reset delay (left half,  $I_2 < I_{2>}$ ) and trip delay (right half,  $I_2 > I_{2>}$ ), example for  $I_{Dyn.Lim.} = 20 \cdot I_{2>}$ .

See [↳ “Explanation for All Characteristics \(»I2>«\)”](#) and [↳ “12.2.3.2 Inverse-Time Characteristics \(»I2>«\)”](#) for details.

### Reset Delay

Various reset modes are available: Resetting [via characteristic](#), delayed and instantaneous.

### Trip Delay

If  $I_{2>} < I_2 < I_{Dyn.Lim.}$ , the trip delay is defined [by the characteristic](#).

For  $I_2 > I_{Dyn.Lim.}$ , the trip delay  $t$  is kept constant at  $t = t_{Dyn.Lim.}$ .

»Char« = IEC VINV

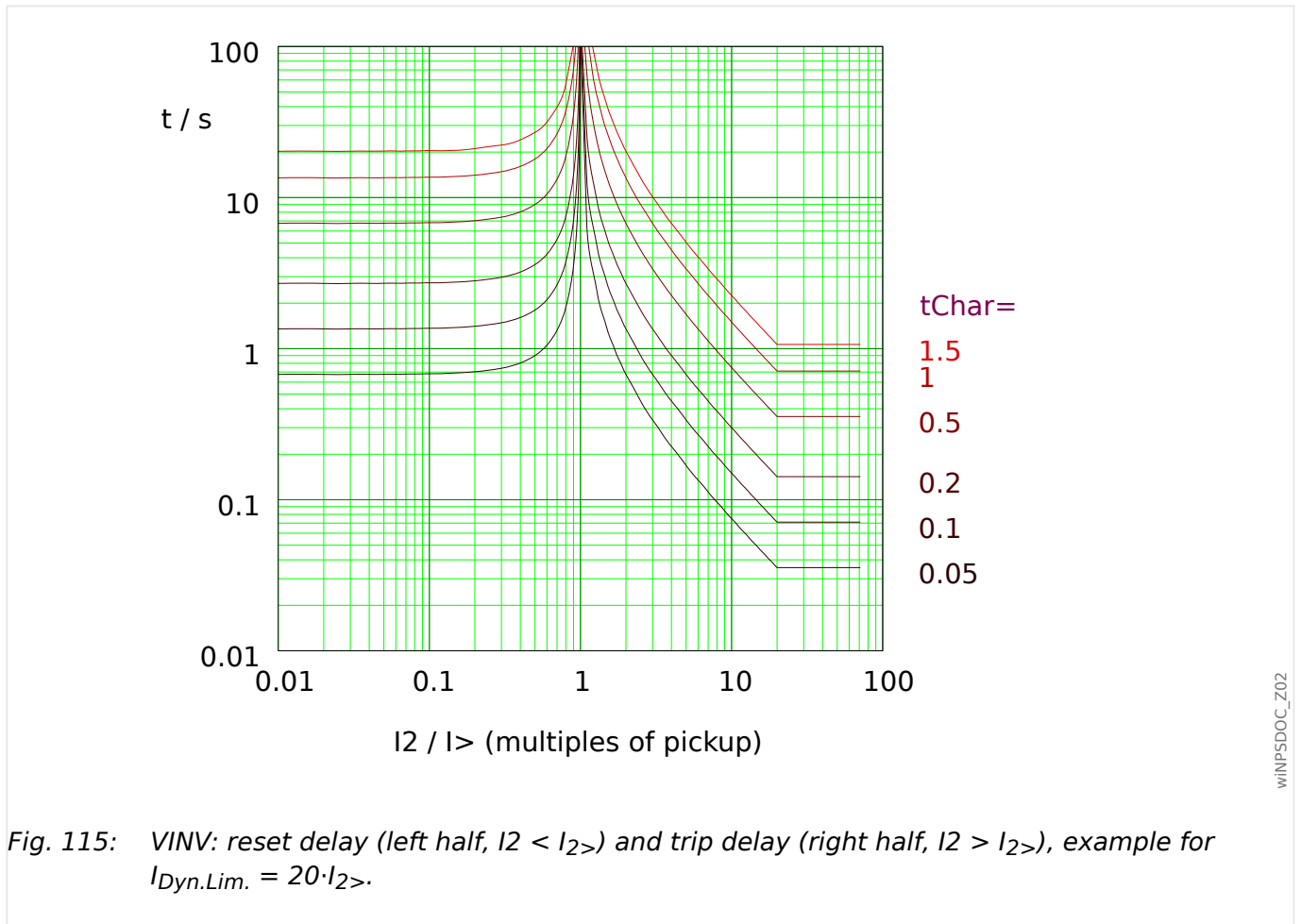

Fig. 115: VINV: reset delay (left half,  $I_2 < I_{2>}$ ) and trip delay (right half,  $I_2 > I_{2>}$ ), example for  $I_{Dyn.Lim.} = 20 \cdot I_{2>}$ .

See [↳](#) “Explanation for All Characteristics (»I2>«)” and [↳](#) “12.2.3.2 Inverse-Time Characteristics (»I2>«)” for details.

**Reset Delay**

Various reset modes are available: Resetting [via characteristic](#), delayed and instantaneous.

**Trip Delay**

If  $I_{2>} < I_2 < I_{Dyn.Lim.}$ , the trip delay is defined [by the characteristic](#).

For  $I_2 > I_{Dyn.Lim.}$ , the trip delay  $t$  is kept constant at  $t = t_{Dyn.Lim.}$ .

## 12.2.3.2.1.3 Extremely Inverse - Characteristic (IEC 60255-151)

»Char« = IEC EINV

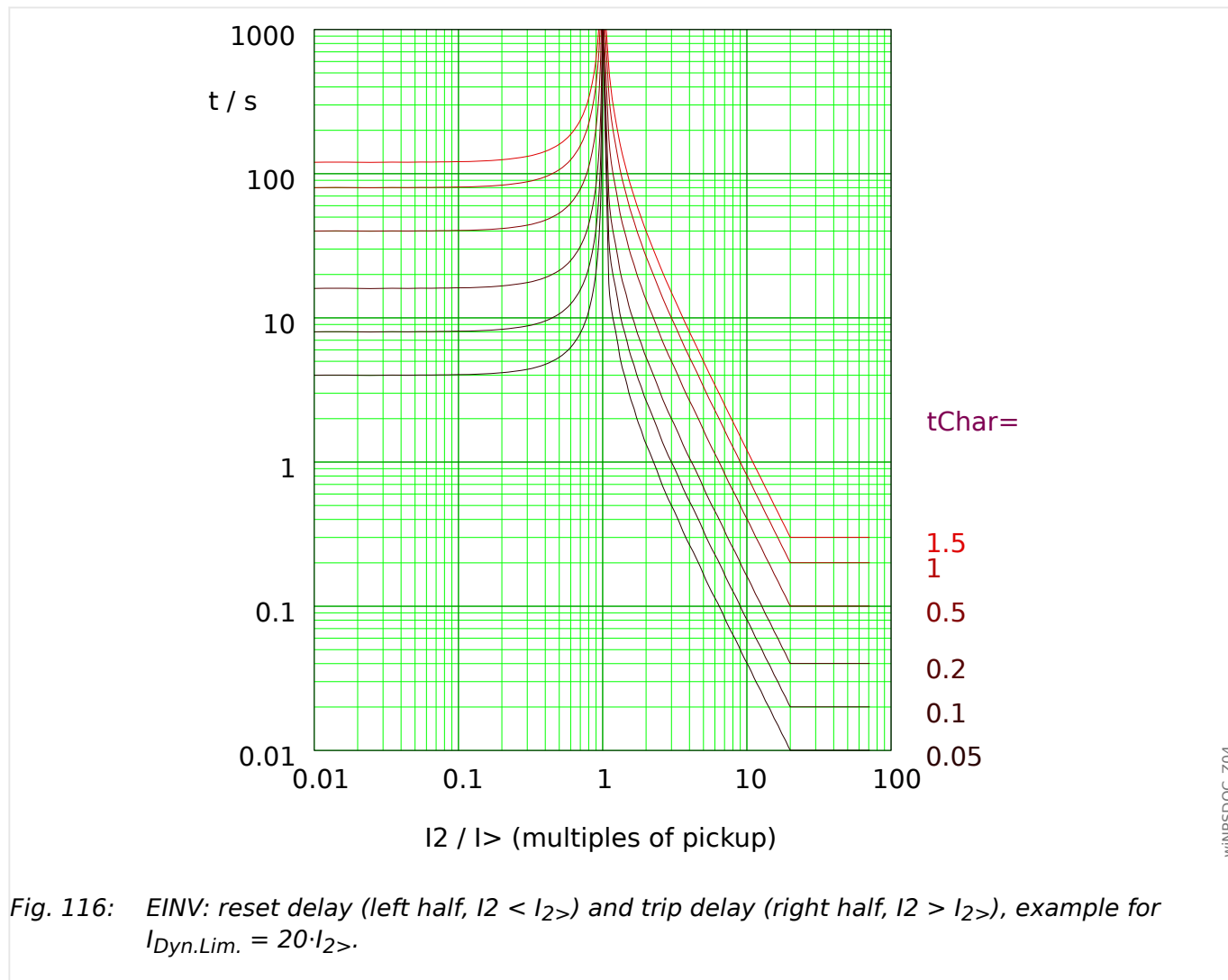

See [↩](#) “Explanation for All Characteristics (»I2>«)” and [↩](#) “12.2.3.2 Inverse-Time Characteristics (»I2>«)” for details.

### Reset Delay

Various reset modes are available: Resetting [via characteristic](#), delayed and instantaneous.

### Trip Delay

If  $I_{2>} < I_2 < I_{Dyn.Lim.}$ , the trip delay is defined [by the characteristic](#).

For  $I_2 > I_{Dyn.Lim.}$ , the trip delay  $t$  is kept constant at  $t = t_{Dyn.Lim.}$ .

»Char« = IEC LINV

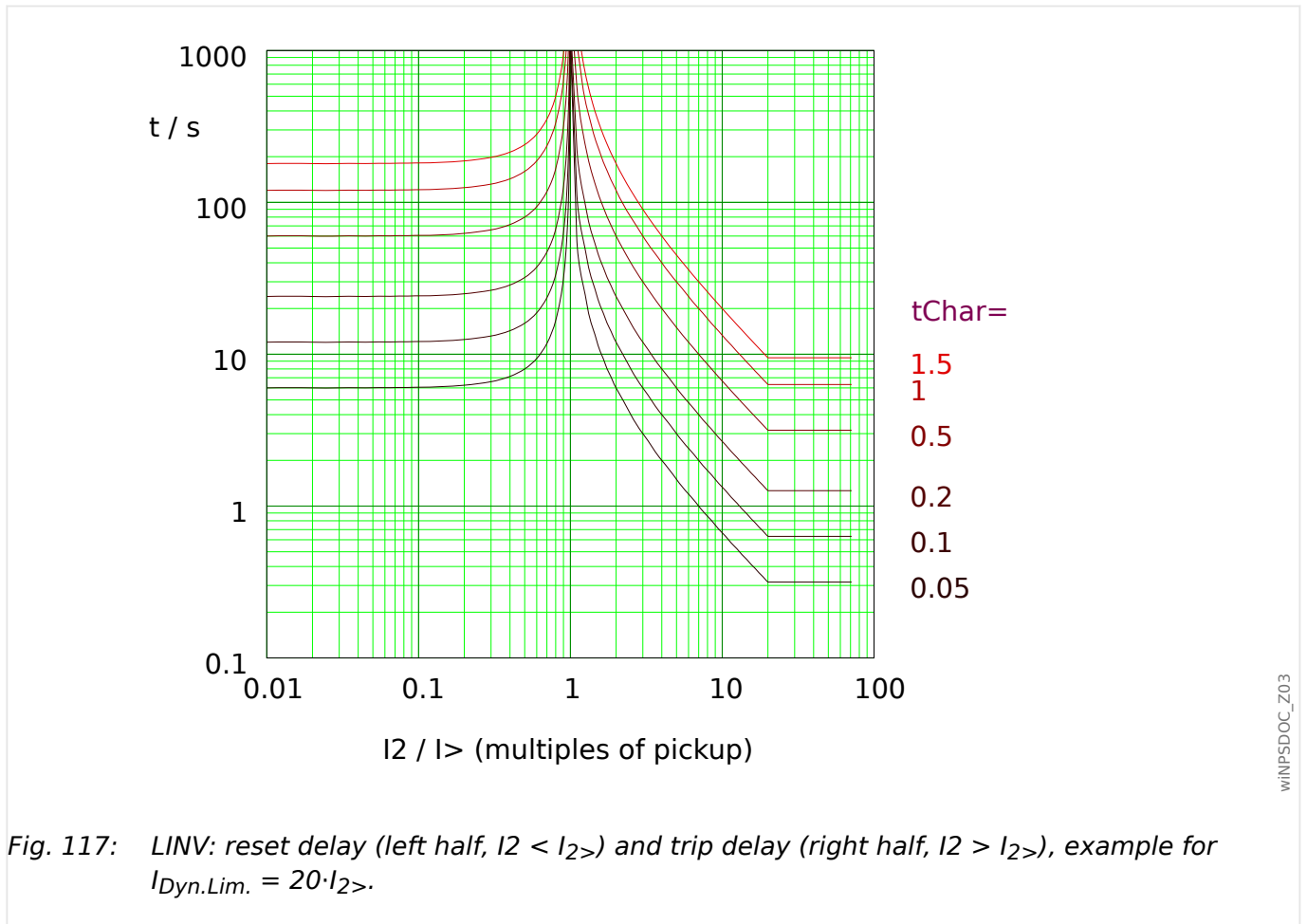

Fig. 117: LINV: reset delay (left half,  $I_2 < I_{>}$ ) and trip delay (right half,  $I_2 > I_{>}$ ), example for  $I_{Dyn.Lim.} = 20 \cdot I_{>}$ .

See [↩](#) “Explanation for All Characteristics (»I2>«)” and [↩](#) “12.2.3.2 Inverse-Time Characteristics (»I2>«)” for details.

**Reset Delay**

Various reset modes are available: Resetting [via characteristic](#), delayed and instantaneous.

**Trip Delay**

If  $I_{>} < I_2 < I_{Dyn.Lim.}$ , the trip delay is defined [by the characteristic](#).

For  $I_2 > I_{Dyn.Lim.}$ , the trip delay  $t$  is kept constant at  $t = t_{Dyn.Lim.}$ .



## 12.2.3.2.2 R Inverse [RINV] - Characteristic

»Char« = RINV

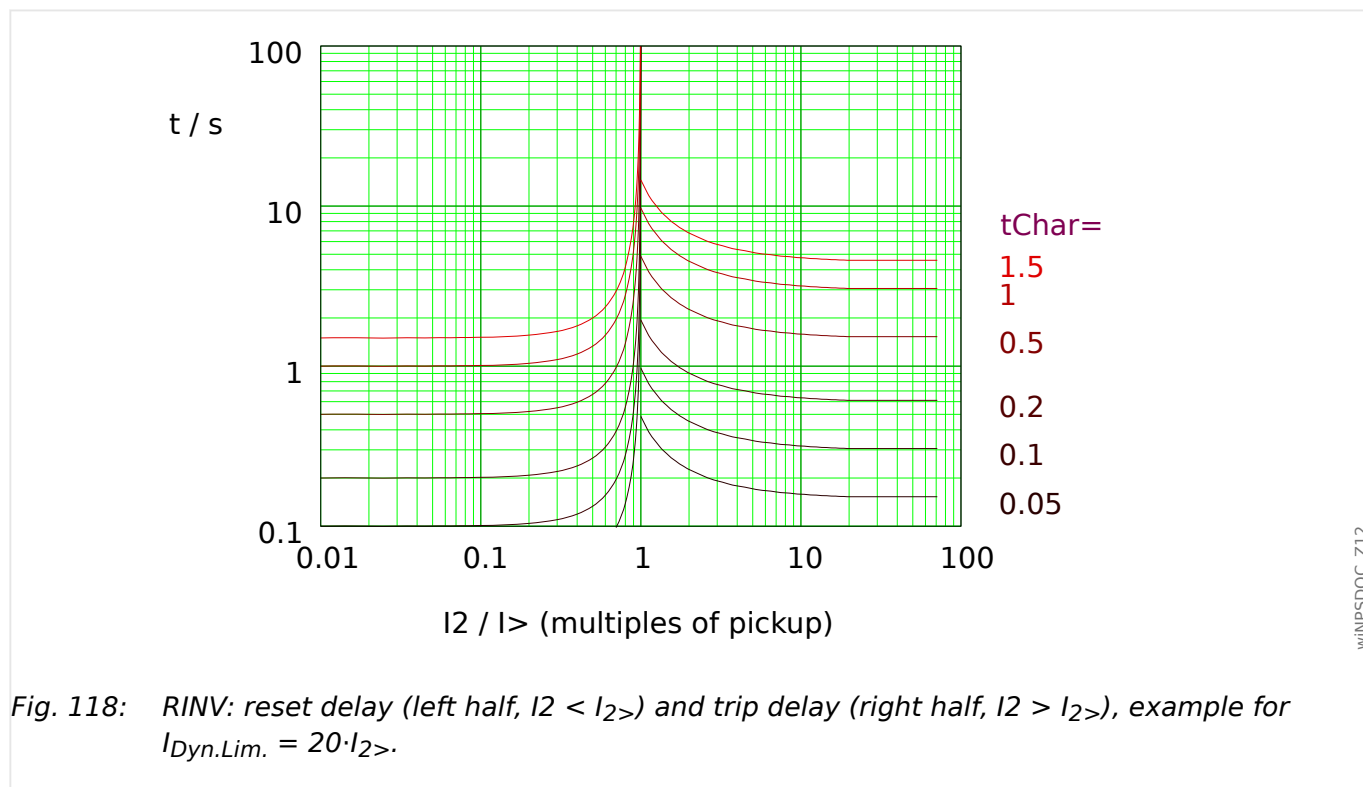

Fig. 118: RINV: reset delay (left half,  $I_2 < I_{2>}$ ) and trip delay (right half,  $I_2 > I_{2>}$ ), example for  $I_{Dyn.Lim.} = 20 \cdot I_{2>}$ .

See [↳ “Explanation for All Characteristics \(»I2>«\)”](#) and [↳ “12.2.3.2 Inverse-Time Characteristics \(»I2>«\)”](#) for details.

### Reset Delay

Various reset modes are available: Resetting [via characteristic](#), delayed and instantaneous.

### Trip Delay

If  $I_{2>} < I_2 < I_{Dyn.Lim.}$ , the trip delay is defined [by the characteristic](#).

For  $I_2 > I_{Dyn.Lim.}$ , the trip delay  $t$  is kept constant at  $t = t_{Dyn.Lim.}$ .

12.2.3.2.3 Fuse Characteristic of an HV Fuse

»Char« = HV Fuse

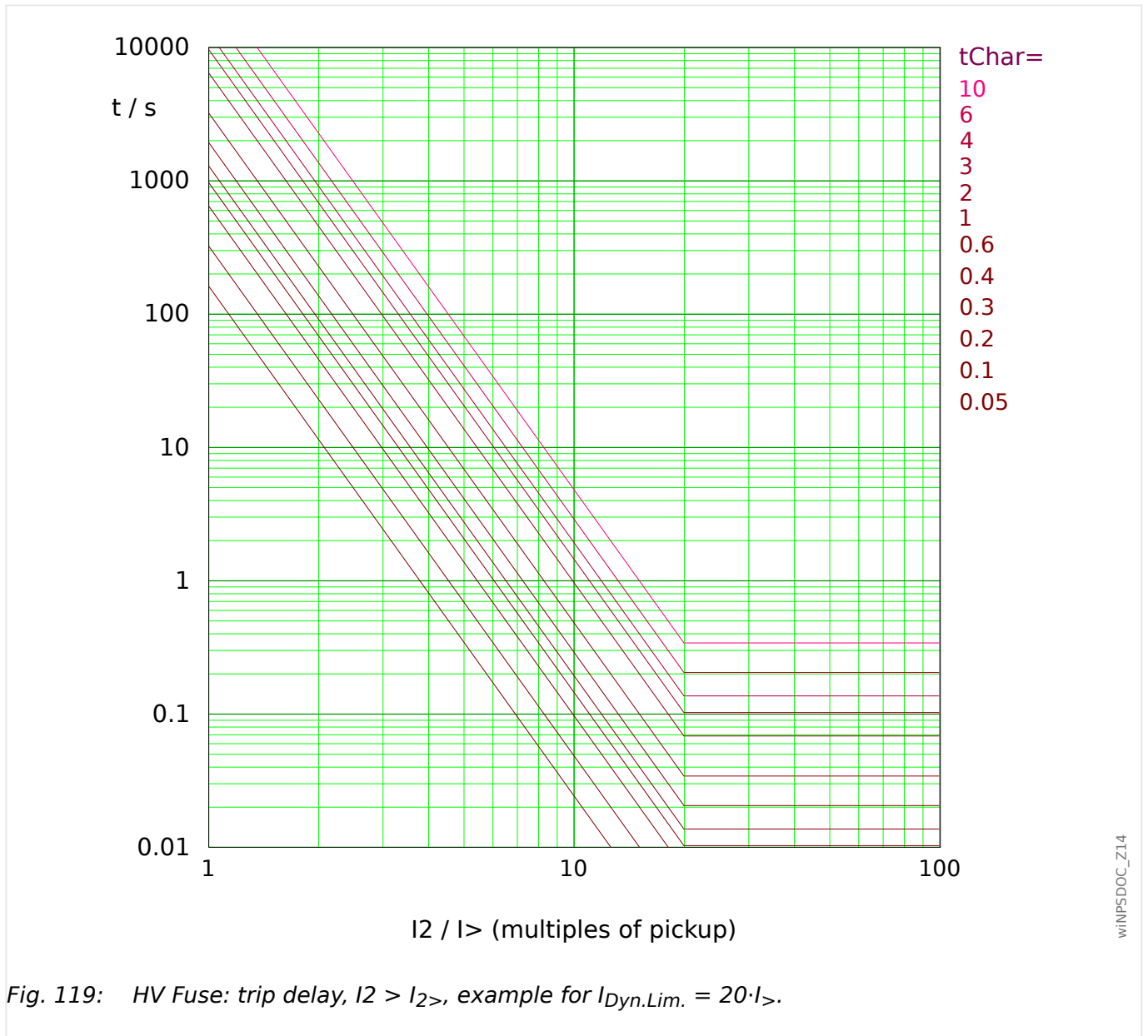

Fig. 119: HV Fuse: trip delay,  $I_2 > I_{>}$ , example for  $I_{Dyn.Lim.} = 20 \cdot I_{>}$ .

See [»Explanation for All Characteristics \(»I2>«\)«](#) and [»12.2.3.2 Inverse-Time Characteristics \(»I2>«\)«](#) for details.

**Reset Delay**

The reset modes “instantaneous” or “definite time” are available. For this characteristic, there is no reset mode with dynamic reset delay.

**Trip Delay**

If  $I_2 < I_{>} < I_{Dyn.Lim.}$ , the trip delay is defined by the characteristic.

For  $I_2 > I_{Dyn.Lim.}$ , the trip delay  $t$  is kept constant at  $t = t_{Dyn.Lim.}$ .

## 12.2.3.2.4 Fuse Characteristic of a Full Range Fuse (FR-Fuse)

»Char« = FR Fuse

Remark: This characteristic is sometimes also called the “Sweden curve”.

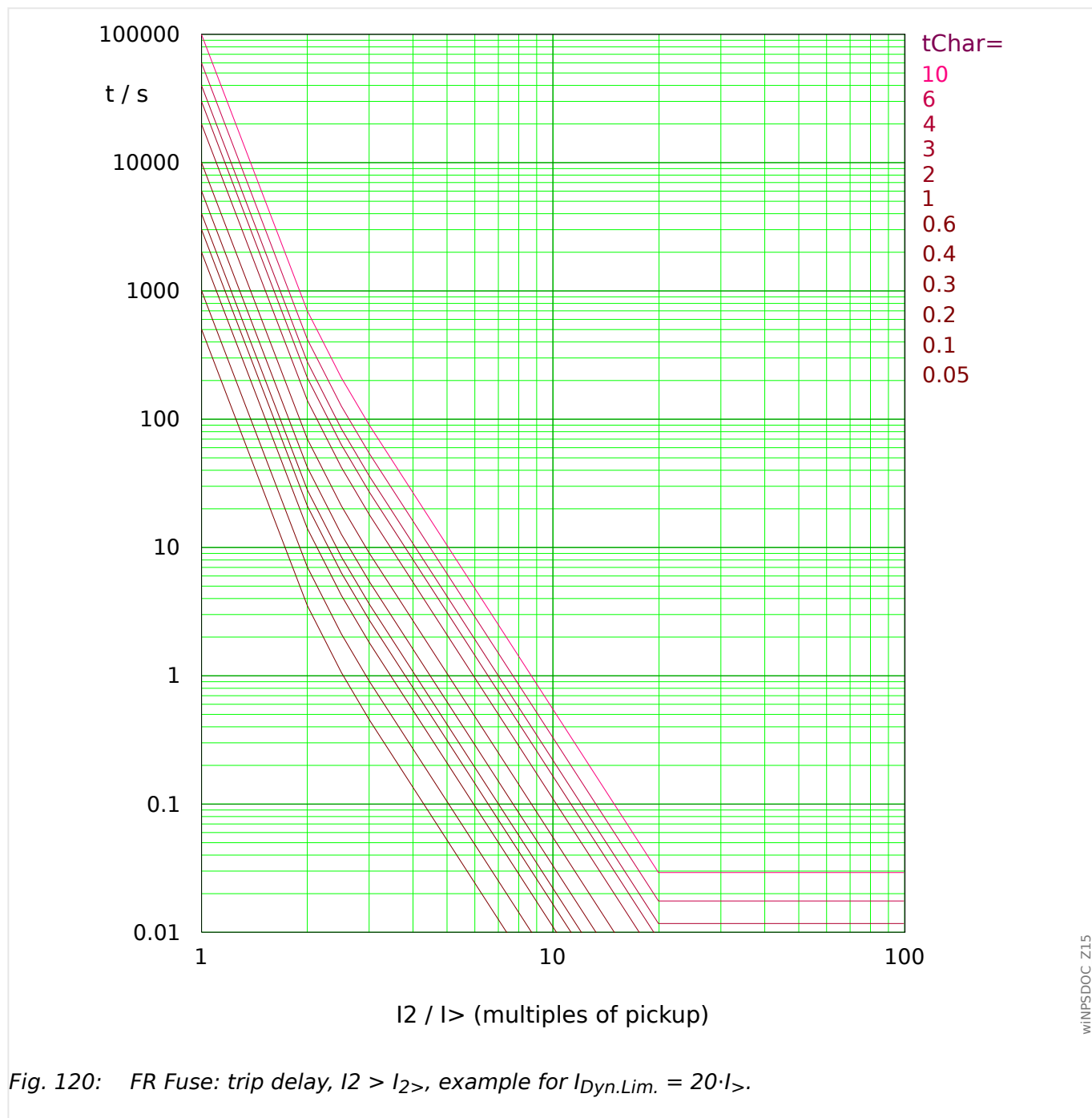

See [↳ “Explanation for All Characteristics \(»I2>«\)”](#) and [↳ “12.2.3.2 Inverse-Time Characteristics \(»I2>«\)”](#) for details.

**Reset Delay**

The reset modes “instantaneous” or “definite time” are available. For this characteristic, there is no reset mode with dynamic reset delay.

**Trip Delay**

If  $I_2 < I_2 < I_{Dyn.Lim.}$ , the trip delay is defined by the characteristic.

For  $I_2 > I_{Dyn.Lim.}$ , the trip delay  $t$  is kept constant at  $t = t_{Dyn.Lim.}$ .

## 12.2.3.2.5 IEEE C37.112 Curves (»I2&gt;«)

## 12.2.3.2.5.1 Moderately Inverse [MINV] - Characteristic (IEEE C37.112)

»Char« = "IEEE MINV"

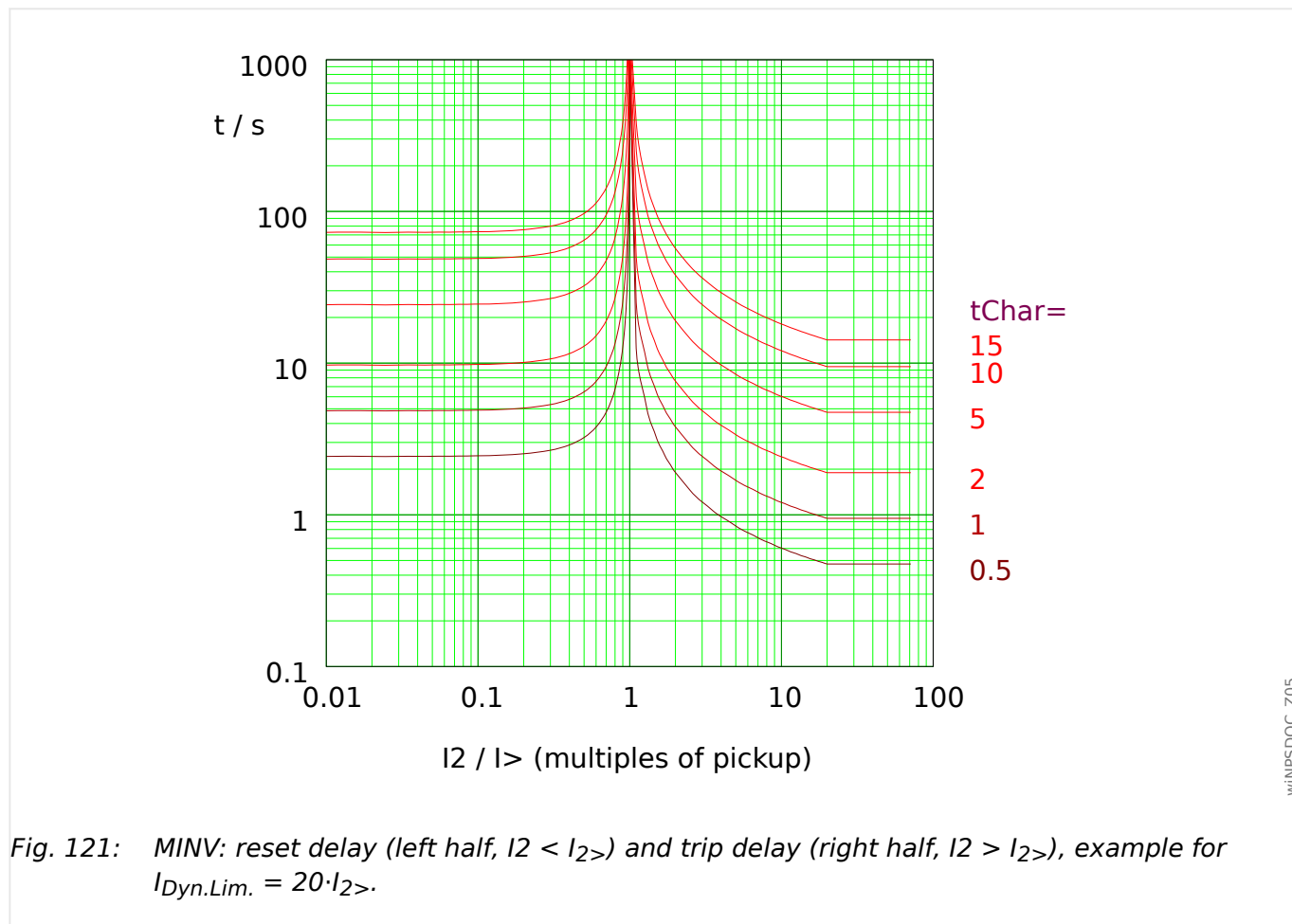

See [»»](#) "Explanation for All Characteristics (»I2>«)" and [»»](#) "12.2.3.2 Inverse-Time Characteristics (»I2>«)" for details.

### Reset Delay

Various reset modes are available: Resetting [via characteristic](#), delayed and instantaneous.

### Trip Delay

If  $I_{2>} < I_2 < I_{Dyn.Lim.}$ , the trip delay is defined [by the characteristic](#).

For  $I_2 > I_{Dyn.Lim.}$ , the trip delay  $t$  is kept constant at  $t = t_{Dyn.Lim.}$ .

»Char« = "IEEE VINV"

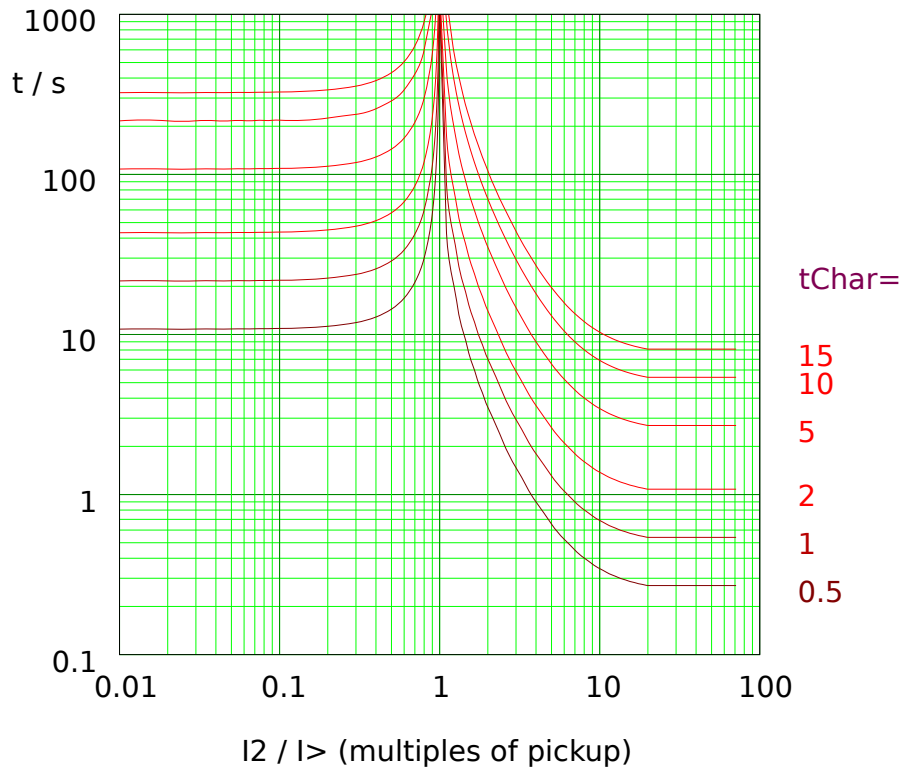

Fig. 122: VINV: reset delay (left half,  $I_2 < I_{2>}$ ) and trip delay (right half,  $I_2 > I_{2>}$ ), example for  $I_{Dyn.Lim.} = 20 \cdot I_{2>}$ .

See [»I2><«](#) "Explanation for All Characteristics (»I2><«)" and [»I2><«](#) "12.2.3.2 Inverse-Time Characteristics (»I2><«)" for details.

**Reset Delay**

Various reset modes are available: Resetting [via characteristic](#), delayed and instantaneous.

**Trip Delay**

If  $I_{2>} < I_2 < I_{Dyn.Lim.}$ , the trip delay is defined [by the characteristic](#).

For  $I_2 > I_{Dyn.Lim.}$ , the trip delay  $t$  is kept constant at  $t = t_{Dyn.Lim.}$ .

## 12.2.3.2.5.3 Extremely Inverse - Characteristic (IEEE C37.112)

»Char« = "IEEE EINV"

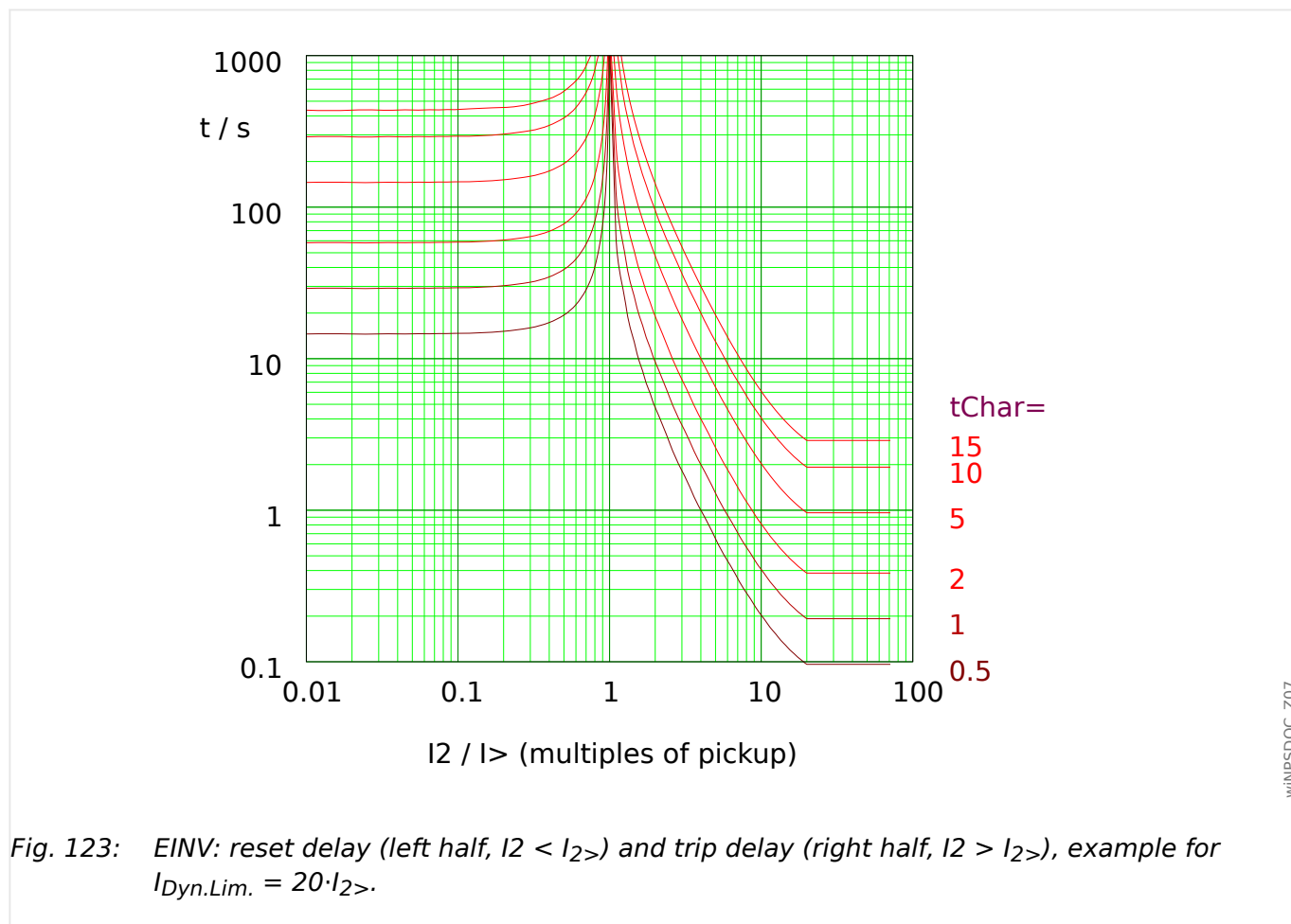

See [↳](#) "Explanation for All Characteristics (»I2>«)" and [↳](#) "12.2.3.2 Inverse-Time Characteristics (»I2>«)" for details.

### Reset Delay

Various reset modes are available: Resetting [via characteristic](#), delayed and instantaneous.

### Trip Delay

If  $I_{2>} < I_2 < I_{Dyn.Lim.}$ , the trip delay is defined [by the characteristic](#).

For  $I_2 > I_{Dyn.Lim.}$ , the trip delay  $t$  is kept constant at  $t = t_{Dyn.Lim.}$ .

12.2.3.2.6 “EF” Curve

»Char« = EF Curve

***Reset Delay***

The reset modes “instantaneous” or “definite time” are available. For this characteristic, there is no reset mode with dynamic reset delay.



**Trip Delay**

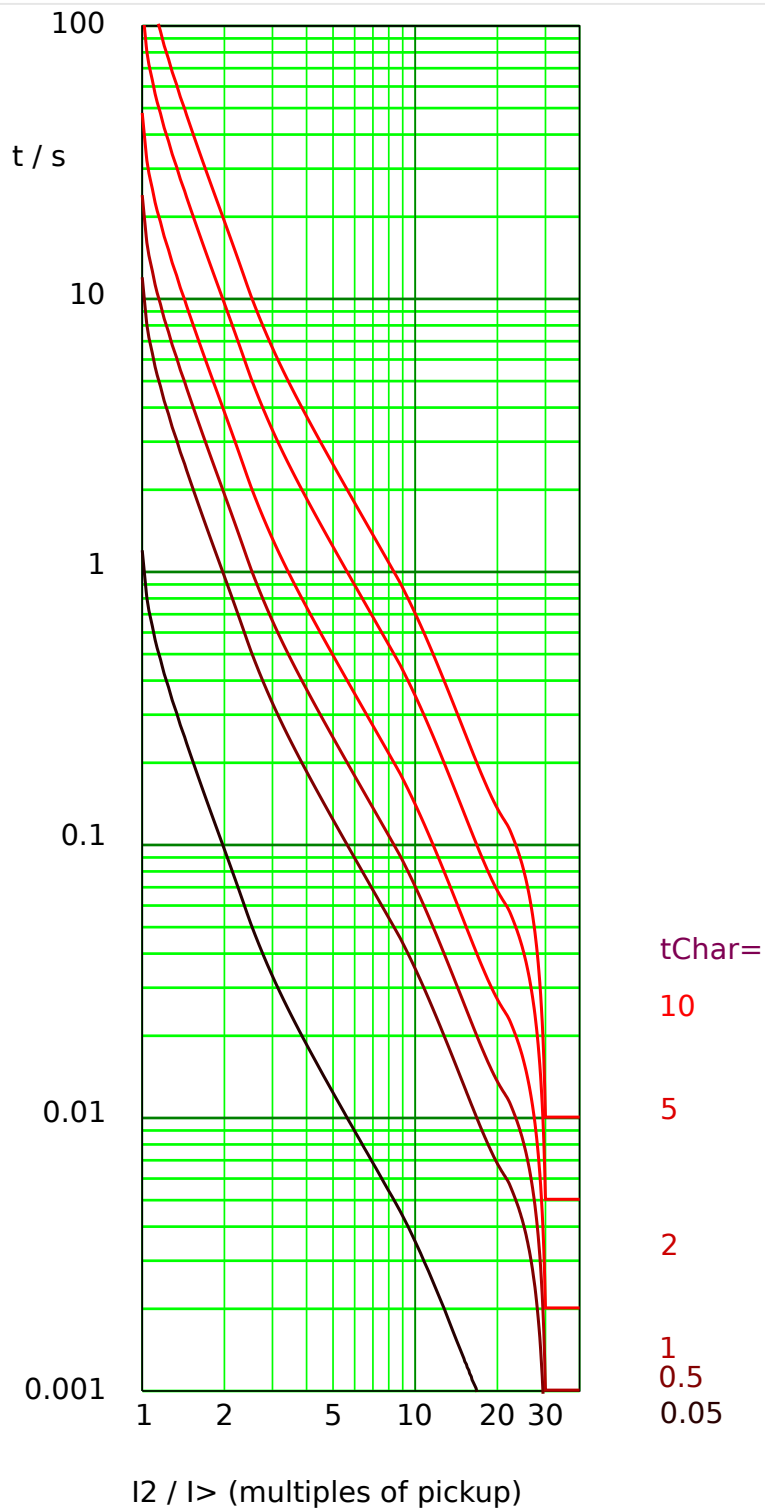

Fig. 124: EF Curve: trip delay,  $I_2 > I_{2>}$ , example for  $I_{Dyn.Lim.} = 30 \cdot I_{2>}$ .

See [↪](#) "Explanation for All Characteristics ( $\gg I_2 > \ll$ )" for details.

wiNPSDOC\_Z16

## 12.3 Requirements for 1 A/5 A Standard CTs with WIC1 Adapter CTs

### WARNING!



In addition to the considerations in this chapter and the requirements mentioned, all applicable national and international standards and regulations have to be followed.

### Symbols

The following table gives an overview of the symbols that are used in the CT requirement section.

$I_{pr}$	Primary rated current of the standard CT
$I_{sr}$	Secondary rated current of the standard CT
$R_{ct}$	Secondary internal wiring resistance of the standard CT
$R_b$	Rated resistive burden of the standard CT
$R_{wic1}$	Impedance of the adapter CT plus WIC1
$R_{add}$	Additional resistance in the secondary circuit of the standard CT. This includes additional wiring (but without the built-in cables of the Adapter CTs), short-circuit rails, etc.
ALF	Accuracy limit factor of the standard CT
$E_k$	Rated knee point e.m.f. of the standard CT
$V_s$	Secondary terminal voltage of the standard CT

When dimensioning the standard current transformers, the following minimum conditions must be fulfilled:

### Minimum Requirement: Make sure that an Overcurrent Causes a Trip

CT class	Minimum Requirement
P, PR	$ALF \geq 20 \cdot \frac{R_{ct} + R_{add} + R_{wic1}}{R_{ct} + R_b}$
PX, PXR	$E_k \geq \frac{20}{1.2} \cdot I_{sr} \cdot (R_{ct} + R_{add} + R_{wic1})$
IEEE / ANSI C-class	$V_s \geq 20 \cdot I_{sr} \cdot (R_{ct} + R_{add} + R_{wic1})$

- $R_{wic1}$  for 1 A CT and normal connection, as shown in [Fig. 21](#):  $R_{wic1} = 0.2 \Omega$
- $R_{wic1}$  for 1 A CT and Holmgreen connection, as shown in [Fig. 22](#):  $R_{wic1} = 0.3 \Omega$
- $R_{wic1}$  for 5 A CT and normal connection, as shown in [Fig. 21](#):  $R_{wic1} = 0.1 \Omega$
- The Holmgreen circuit is not available with 5 A CTs, see also [Chapter 3.3.3](#).

The maximum permitted short-circuit current of the adapter CTs is  $100 I_n$  for 1 second. (See the [Technical Data](#).) If the fault current of your application is higher than this please contact our Support team; under some circumstances this can be tolerable.

**Example Calculation for a P/PR Class CT**

Standard CT, 1 A	$I_{pr} = 25 \text{ A}$ $I_{sr} = 1 \text{ A}$ $R_{ct} = 1.5 \ \Omega$
Maximum primary short-circuit current	$I_{psc,max} = 4.0 \text{ kA}$
Rated resistive burden	$R_b = \frac{2.5 \text{ VA}}{(1 \text{ A})^2} = 2.5 \ \Omega$
Burden of short-circuit rail in the secondary circuit of the standard CT	$R_{add} = 2.0 \ \Omega$

This example assumes a [normal connection](#) (i. e. no [Holmgreen](#)) for the standard CTs.

**Calculation of the minimum requirement:**

$$ALF \geq 20 \cdot \frac{R_{ct} + R_{add} + R_{wic1}}{R_{ct} + R_b} = 20 \cdot \frac{1.5 \ \Omega + 2.0 \ \Omega + 0.2 \ \Omega}{1.5 \ \Omega + 2.5 \ \Omega} = 18.5$$

The ALF of the standard CT must be greater than 18.5.

## 12.4 Revision History

This chapter lists all WIC1 changes since version 1.0.

### ***Out-of-Date Documentation?***



This publication may have been revised or updated since this copy was produced. To verify that you have the latest revision, please visit the download section of our website:

- **<https://docs.SEGelectronics.de/wic1>**

Please check this download area for the latest revision of this Technical Manual and whether there is an Errata Sheet with updated information. (The ID of every document is printed on its cover page.)

### **12.4.1 Version: 1.0**

- Date: 2022-April-11
- Revision: 1.0.b

#### ***Hardware***

Initial Release

- After several specimen delivered to selected customers for tests / approval, this is the initial release that has been made publicly available.

#### ***Software***

Initial Release

## 12.4.2 Version: 1.1

- Date: 2022-September-05
- Revision: 1.1.a

### **Hardware**

No changes.

### **Software**

Better support for the [Adapter CTs](#). In particular, it is possible now to have primary current values displayed when using the 1 A or 5 A Adapter CTs.

### **User Manual / Technical Documentation**

Numbered input signals within a diagram are now hyperlinks, and a click takes you to a page where this numbered signal is explained or shown as an output signal.

(See also [↪](#) “2.5.1 Symbols in Function Diagrams”.)

### 12.4.3 Version: 2.0

- Date: 2022-October-31
- Revision: 2.0.a

#### **Hardware**

The WIC1-4 can now be ordered with an RS485 interface. It can be used for the SCADA protocol *Modbus RTU*. See [↳ “3.7 Serial Interface RS485 \(WIC1-4... only\)”](#).

#### **Software**

*Modbus RTU* is available now with a, externally supplied WIC1-4. See [↳ “4.1 Modbus® \(WIC1-4 only\)”](#).

With an externally supplied WIC1-4, there is a new protection function »Cold Load Pickup« available. See [↳ “5.11 CLPU - Cold Load Pickup \(WIC1-4 only\\*\)”](#).

A new supervision function »Breaker Wear« is available. See [↳ “5.15.1 BkrWear”](#).

The menu item [Operation] has a sub-menu item [Condition Monitoring] now, with new entries:

- [Peak Current Ptr (Val.)] mimics an analog pointer instrument by calculating a time-average of the maximum phase current. See [↳ “5.15.4 Condition Monitoring - Peak Current Pointer”](#).
- [Life Load] evaluates the operating time in dependency on the phase current flow and can (optionally) issue an alarm signal if the WIC1 has been running with too high load for a particular time. See [↳ “5.15.3 Condition Monitoring - Life Load”](#).
- [BkrWear] the values of the new supervision function »Breaker Wear«. (See above.)

Both [Peak Current Ptr (Val.)] and [Life Load] allow for checking whether the WIC1 - and therefore the protected object as well - have been under high load. There are sub-menu items for displaying these two statistics either as a table of values or as a diagram (drag indicator graphics or histogram, respectively).

# Index

## A

### ANSI

46 .....	164, 167
49 .....	171
50 .....	149, 174
50BF .....	187
50N/G .....	159
51 .....	149
51N/G .....	159
51Q .....	164, 167
62BF .....	187
Adapter CTs (1 A) .....	77
Alarm-/Trip Cause display .....	203
Auto Fault Report .....	203
Auto Refresh .....	42
access password .....	55
asterisk "*" .....	118
auxiliary voltage supply .....	87

## B

Backup (phase overcurrent) Protection .....	189
Backup (phase overcurrent) protection .....	94
BkrWear .....	191

## C

CBF .....	187
CLPU .....	180
CTs	
properties .....	72
quick selection .....	76
selection / example calculation .....	74



technical data . . . . .	73
test windings . . . . .	215
“E”-type . . . . .	74
Circuit breaker failure protection module . . . . .	187
Cold Load Pickup Module . . . . .	180
Condition Monitoring . . . . .	197, 199
Connection Settings . . . . .	121
characteristics (earth/ground overcurrent) . . . . .	325
characteristics (phase overcurrent) . . . . .	307
characteristics (unbalanced load) . . . . .	344
circuit breaker . . . . .	142
configuration via Smart view (offline) . . . . .	42

## **D**

DEFT (Unbalanced Load-Stage characteristic) . . . . .	346
DEFT (earth/ground overcurrent characteristic) . . . . .	327
DEFT (phase overcurrent characteristic) . . . . .	309
DIP switches . . . . .	56
Settings Overview . . . . .	282
validity of settings . . . . .	41
Device Model . . . . .	122
DiggiMEC . . . . .	33, 115
Favorites key »★« . . . . .	113
Introduction . . . . .	108
flag indicators – output relays . . . . .	127
front panel parts . . . . .	110
DiggiMEC flag indicators / output relays	
Set + Reset . . . . .	127
position, terminals, connectors . . . . .	123
DiggiMEC flag indicators – output relays	
latching . . . . .	128

testing ..... 129

Digital Input ..... 85, 86, 87

Digital Inputs (for position indication) ..... 143

Direct Commands ..... 46

Dual-Powered WIC1 ..... 19

date and time ..... 107

device start ..... 208

dual power ..... 87

**E**

EF Curve (Unbalanced Load-Stage characteristic) ..... 360

EF Curve (earth/ground overcurrent characteristic) ..... 341

EF Curve (phase overcurrent characteristic) ..... 323

external protection

    function ..... 184

    input ..... 85

external reset ..... 87

external trip ..... 87

**F**

FR Fuse (Unbalanced Load-Stage characteristic) ..... 355

FR Fuse (earth/ground overcurrent characteristic) ..... 336

FR Fuse (phase overcurrent characteristic) ..... 318

Fault Display screen (Overlay / Pop-up) ..... 203

Favorites key »★« ..... 113

factory defaults (reset) ..... 42, 54, 115

flag indicator ..... 93

flag indicators / output relays

    DiggiMEC ..... 123

flag indicators – output relays	
DiggiMEC .....	127
force trip command .....	139
fused contactor .....	142

**G**

Ground (earth) current protection stage .....	159
---	-----

**H**

HEX switches .....	56
Settings Overview .....	286
validity of settings .....	41
HMI .....	41, 110, 115
HV Fuse (Unbalanced Load-Stage characteristic) .....	354
HV Fuse (earth/ground overcurrent characteristic) .....	335
HV Fuse (phase overcurrent characteristic) .....	317

**I**

I2/I1> .....	164
I2> .....	167
I> .....	149
I>> .....	149
I>>> .....	149
IEC EINV (Unbalanced Load-Stage characteristic) .....	351
IEC EINV (earth/ground overcurrent characteristic) .....	332
IEC EINV (phase overcurrent characteristic) .....	314
IEC LINV (Unbalanced Load-Stage characteristic) .....	352
IEC LINV (earth/ground overcurrent characteristic) .....	333

IEC LINV (phase overcurrent characteristic) .....	315
IEC NINV (Unbalanced Load-Stage characteristic) .....	349
IEC NINV (earth/ground overcurrent characteristic) .....	330
IEC NINV (phase overcurrent characteristic) .....	312
IEC VINV (Unbalanced Load-Stage characteristic) .....	350
IEC VINV (earth/ground overcurrent characteristic) .....	331
IEC VINV (phase overcurrent characteristic) .....	313
IEC 60870-5-103 .....	88
IEEE EINV (Unbalanced Load-Stage characteristic) .....	359
IEEE EINV (earth/ground overcurrent characteristic) .....	340
IEEE EINV (phase overcurrent characteristic) .....	322
IEEE MINV (Unbalanced Load-Stage characteristic) .....	357
IEEE MINV (earth/ground overcurrent characteristic) .....	338
IEEE MINV (phase overcurrent characteristic) .....	320
IEEE VINV (Unbalanced Load-Stage characteristic) .....	358
IEEE VINV (earth/ground overcurrent characteristic) .....	339
IEEE VINV (phase overcurrent characteristic) .....	321
IG> .....	159
IG>> .....	159
IH2 .....	155
Ipeak> .....	174
impulse output	
flag indicator .....	93
trip coil .....	93

## K

keys	
OK .....	118
keys during power-on .....	115

## L

LED	
Error .....	56, 99, 99
Pickup/Trip .....	56, 99
Ready .....	56, 99, 99
System (Ready/Error) .....	99
LED Test .....	102, 112
LED »System« .....	225
LEDs	
DiggiMEC .....	99, 102, 102
Latching .....	102
Pickup / TripCmd .....	102
System LED .....	99
Trip Command .....	102
WIC1 .....	99, 102
configuration .....	102
Life Load .....	50, 197
Load Current Histogram .....	197

## M

Measured Value .....	46
Modbus .....	88, 130
Module Input .....	46
Module Inrush .....	155
manual trip command .....	139
measured values	
display options .....	48
menu structure .....	116

message (self-supervision) . . . . . 209

**N**

Negative-Sequence Current Protection . . . . . 167

navigation . . . . . 110

**O**

Order Form (Order Code) . . . . . 33

offline configuration . . . . . 42

operating mode

    Backup Protection . . . . . 189

    Protection-Only . . . . . 100, 189

operating software . . . . . 121

operation . . . . . 41

output relays / flag indicators

    DiggiMEC . . . . . 123

output relays – flag indicators

    DiggiMEC . . . . . 127

**P**

PC connection

    USB-C . . . . . 121

Parameters . . . . . 46

Peak Current Ptr . . . . . 50, 199

Peak-Value Overcurrent . . . . . 174

Phase Overcurrent Stage . . . . . 149

Primary test . . . . . 218

Protection-Only mode . . . . . 189

panel . . . . . 110, 115

parameters . . . . . 118

password . . . . . 55

passwords

    reset . . . . . 55

position indication . . . . .	142
position indication (switchgear) . . . . .	142

## Q

question mark “?” (parameter implausibility) . . . . .	120
--	-----

## R

RINV (Unbalanced Load-Stage characteristic) . . . . .	353
RINV (earth/ground overcurrent characteristic) . . . . .	334
RINV (phase overcurrent characteristic) . . . . .	316
RS485 . . . . .	88
RXIDG (earth/ground overcurrent characteristic) . . . . .	343
Receive Data from Device . . . . .	121
Recorder	
Fault records . . . . .	201
Restart (reboot) . . . . .	225
reboot . . . . .	208
reboot codes . . . . .	208
remote trip input . . . . .	85
reset	
Alarm-/Trip Cause display . . . . .	51, 203
LEDs . . . . .	51
flag indicators . . . . .	51
to factory defaults . . . . .	51
reset delay (earth/ground overcurrent) . . . . .	325
reset delay (phase overcurrent) . . . . .	307
reset delay (unbalanced load) . . . . .	344
reset latched states . . . . .	51
reset to factory defaults . . . . .	42, 54, 115

## S

SOTF .....	177
Security Logger .....	55
Self-Supervision Contact .....	95
Self-Supervision messages .....	209
Signals .....	46
Smart view .....	33, 121
Auto Refresh .....	42
Receive Data from Device .....	42
Statistic .....	197
Statistik .....	199
Supply of a WIC1 .....	23
Sweden curve (Unbalanced Load-Stage characteristic) .....	355
Sweden curve (earth/ground overcurrent characteristic) .....	336
Sweden curve (phase overcurrent characteristic) .....	318
Switch Onto Fault - Module .....	177
System-LED .....	225
scaling of measured values .....	48
secondary test .....	218
security-related messages .....	209
serial interface .....	88
setting values .....	118
start-up codes .....	208
switchgear .....	142
system time .....	107

## T

ThR .....	171
Thermal Overload .....	171
Typecode (see Order Form) .....	33
terminals	



max. torques of the screws .....	59, 124
test sockets .....	56, 215, 217, 219
time, date .....	107
torque (max. t. of the screws) .....	59, 124
trip delay .....	226
trip delay (earth/ground overcurrent) .....	325
trip delay (phase overcurrent) .....	307
trip delay (unbalanced load) .....	344

## **U**

Unbalanced Load Protection .....	164
----------------------------------	-----

## **V**

Values .....	46
--------------	----

## **W**

WI1-SZ4, WI1-SZ5 .....	93
WIC1 g1 .....	18
WIC1 g2 .....	18
WiPara file .....	46

## **⚙**

### **⚙ Signal References in Function Diagrams**

( 10 ) .....	144, 144, 145, 145, 146
( 11 ) .....	144, 144, 145, 145, 146
( 12 ) .....	144
( 18 ) .....	135
( 19 ) .....	134, 150, 160, 165, 168, 172, 175, . 178, 185
( 20 ) .....	134, 151, 160, 165, 168, 172, 175, . 178, 185, 188, 195
( 21 ) .....	134, 151, 160, 165, 168, 172, 175, . 178, 185
( 24 ) .....	150



( 25 ) ..... 150

( 26 ) ..... 150

( 27 ) ..... 160, 175

( 28 ) ..... 175

( 29 ) ..... 175

( 30 ) ..... 143

( 31 ) ..... 143

( 34 ) ..... 151

( 35 ) ..... 151

( 36 ) ..... 151

( 37 ) ..... 160, 175

( 38 ) ..... 175

( 39 ) ..... 175

( 44 ) ..... 150

( 45 ) ..... 150

( 46 ) ..... 150

( 49 ) ..... 134, 137

( 50 ) ..... 134

( 51 ) ..... 134, 138

( 52 ) ..... 134

( 53 ) ..... 189

( 61 ) ..... 137

( 62 ) ..... 137

( 63 ) ..... 137

( 1 ) ..... 135

( 2 ) ..... 141, 195

( 3 ) ..... 135

( 5 ) ..... 156

( 6 ) ..... 156

( 7 ) ..... 156

( 8 ) ..... 156

## WI Line

## WIC1

### MANUAL

[docs.SEGelectronics.de/wic1](https://docs.SEGelectronics.de/wic1)

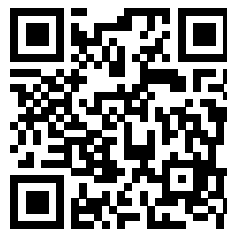

SEG Electronics GmbH reserves the right to update any portion of this publication at any time. Information provided by SEG Electronics GmbH is believed to be correct and reliable. However, SEG Electronics GmbH assumes no responsibility unless otherwise expressly undertaken.



#### SEG Electronics GmbH

Krefelder Weg 47 • D-47906 Kempen (Germany)

Telephone: +49 (0) 21 52 145 1

Internet: [www.SEGelectronics.de](http://www.SEGelectronics.de)

#### Sales

Telephone: +49 (0) 21 52 145 331

Fax: +49 (0) 21 52 145 354

E-mail: [sales@SEGelectronics.de](mailto:sales@SEGelectronics.de)

#### Service

Telephone: +49 (0) 21 52 145 600

Fax: +49 (0) 21 52 145 354

E-mail: [support@SEGelectronics.de](mailto:support@SEGelectronics.de)

Complete address / phone / fax / email information for all locations is available on our website.