

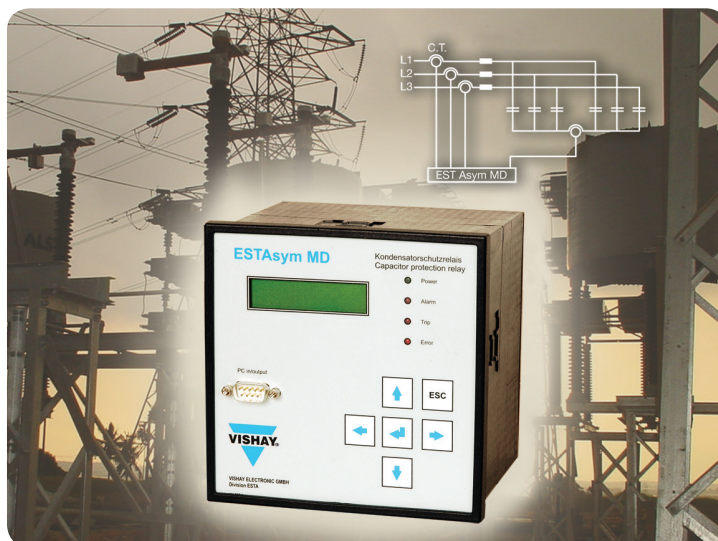

ESTAsym MD Capacitor Protection Relay



CHARACTERISTICS

The microprocessor-based ESTAsym MD capacitor protection relay uses a versatile integrated current measuring multifunction relay design to enable the protection of medium and high voltage capacitor banks. Using FFT techniques, the ESTAsym MD calculates the fundamental and harmonic currents from measured line and unbalance currents, and uses these values to implement individual protection functions.

The ESTAsym MD capacitor protection relay is particularly appropriate for capacitor banks connected in double star and bridge circuit configurations. The following protective functions are provided by the ESTAsym MD:

- Capacitor unbalance protection
- Line current unbalance protection
- Overvoltage protection
- Overheating protection
- Ground fault protection
- Overcurrent protection
- Undercurrent protection
- Capacitor bank discharge timer

RESOURCES

- For technical questions contact esta@vishay.com
- Sales Contacts: www.vishay.com/doc?99915





Capacitor Unbalance Protection

The relay measures the circuit's natural unbalance at its fundamental frequency and compensates for both amplitude and phase to zero shifts, to enable detection of further changes in both amplitude and phase angle. The phase current input I_{L1} is used as the synchronizing input for the compensation. The phase angle indicates the leg in which the change in capacitance has occurred. The protection has two stages, warning and tripping, both with an adjustable definite timer. A trip signal is initiated if the associated threshold is exceeded for the definite time setting. The trip values obtained mathematically relate to the nominal voltage of the capacitor equipment. Therefore, accurate protection is not maintained in case of voltage fluctuation - especially with decreased voltage.

Line Current Unbalance Protection

The relay calculates the fundamental frequency line current unbalance due to faults or failures within the capacitor bank. The line current unbalance is calculated from three-phase line currents. The protection includes two stages, warning and tripping, both with an adjustable definite timer. A trip signal is initiated if the value of the line unbalance current exceeds the selected setpoint value for the definite time.

Overvoltage Protection

The purpose of the overvoltage protection is to protect the capacitor bank against overload due to fundamental and harmonics currents, which may lead to dielectric breakdown, i.e. short-circuit in a capacitor element. The capacitor bank voltage is calculated from the three-phase line fundamental frequency component current and from the harmonic currents. The overvoltage factor is calculated and continuously compared with a variable threshold. The user may select between a definite time characteristic and an inverse time characteristic according to the ANSI curve. A trip signal is output if the setpoint value is exceeded for the definite time.

Overheating Protection

The overheating protection function is intended to be used for the protection of series reactance coils used within capacitor banks. This protection works by measuring the RMS three-phase line currents and comparing them with an adjustable threshold. The protection feature has two stage options, warning and tripping, both with adjustable definite-time delay, or the user can select the tripping time depending on the ratio of the actual current to the nominal current. The warning time is half of the tripping time. If the current exceeds the relevant setpoint value for the definite-time delay, a tripping or warning signal is initiated.

Ground Fault Protection

The protection calculates the fundamental frequency ground fault current, as the value of the vector sum of the three-phase line currents. The protection has two stages, warning and tripping, both with adjustable definite time. A trip signal is initiated if the amplitude of the ground fault current exceeds the selected setpoint value for the definite time.

Overcurrent Protection

The protection stage measures the fundamental frequency of three-phase currents and compares them with an adjustable threshold. This function may be used for short-circuit protection. A trip signal is initiated if the value of the line current exceeds the selected setpoint value for the definite time.

Undercurrent Protection

The undercurrent protection function is intended for the detection of capacitor bank disconnection. In case of voltage loss in the feeding bus, the capacitor bank has to be disconnected from the system to prevent reapplication of the voltage on the capacitors before they are fully discharged. The stage starts if all the three-phase currents fall below the set level. If the undercurrent condition persists for an interval longer than the set operating time, the trip signal is initiated.



ESTAsym MD

Vishay ESTA

Capacitor Bank Discharge Timer

The relay includes an adjustable timer, started by the circuit breaker auxiliary contacts, which stops the breaker from reclosing until the capacitor bank is discharged to an acceptable voltage level for switching in.

PC Software

The PC software provided with ESTAsym MD allows all settings to be made easily. All setting data is stored in a setup file.

Data Storage

The ESTAsym MD stores all data, including date and time information, in a report file. The included PC software provides you with convenient access to this data.

FFT Analysis and Real Time Measuring

The PC software allows users to see the actual current values of the four measuring inputs up to the thirteenth harmonic.

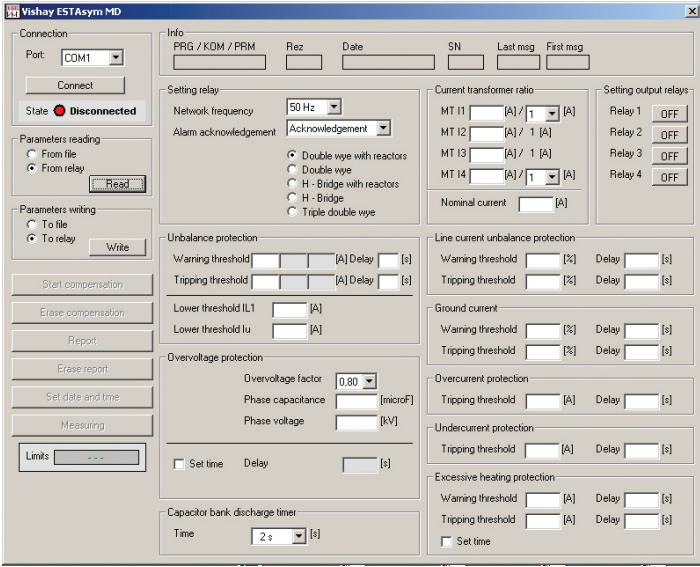

Application

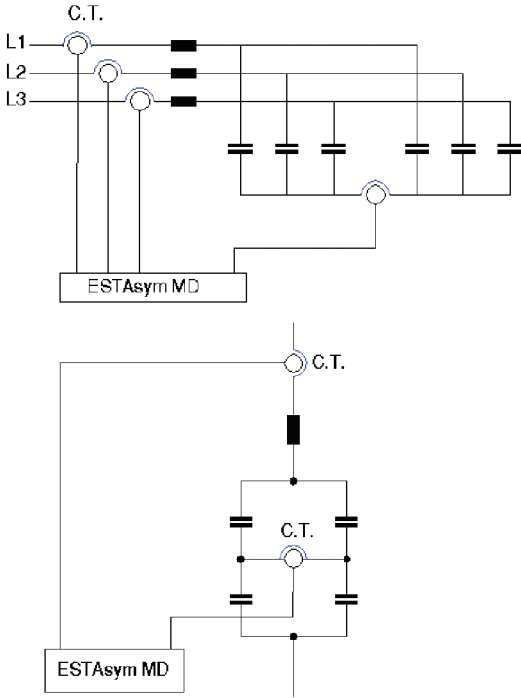

The double star circuit generates a sum current the size and phase of which result from the three unbalance currents. Using the reference current, the ESTAsym MD can analyze the sum current into the three unbalanced currents. Each change of the sum current can take place only in the same phase of the capacitor current. Thus the ESTAsym MD can reveal the partial path in which the defective capacitor unit is located. This means that only 1/6 of the capacitors need to be checked.

Within the bridge circuit, the phase position of the unbalance current L1, L2 and L3 in relation to the reference current is 0, +120, or +240 degrees. The ESTAsym MD can reveal the fault phase and the bridge circuit branch in which the faulty capacitor unit is located.

It is possible to configure the four current inputs of the ESTAsym MD for different applications. For a YY- or bridge connection, inputs 1-3 will be the three line currents, and the fourth input would be the unbalance current. It is also possible to use the first input to measure the line current and inputs 2-4 can be used for the unbalance measurements. Thus it is possible to control three individual YY or bridge connections with different unbalance settings for each bank.



Technical Data

Measuring Circuits	
Rated Current	four current inputs, each can be parameterized to 1 A or 5 A
Thermal Current Withstand	continuously 15 A / for 1 second 100 A
Galvanic Separation	via current voltage transformer, dielectric strength of 2 kV
Power Consumption per Measuring Circuit	1 VA
Measurement Accuracy	Class 1
Rated Frequency	50 Hz / 60 Hz
Auxiliary Supply	
Standard	100 V - 375 V _{DC} or 100 V - 240 V _{AC} 50 Hz / 60 Hz
Option	18 V - 75 V _{DC}
Output Contact Rating	
Signal Outputs	potential-free change-over switch contacts for alarm and switch-off
	the normal position of the relay can be selected, picked up, or released
	contact rating 8 A / 265 V _{AC} or 0.3 A / 300 V _{DC} or 8 A / 30 V _{DC}
Interface	
	RS232 (9600 Bd) on the front panel and RS485 and RS232 on the rear panel
Mechanical Structure	
Front Plate / Switchboard Cutout / Depth	142 mm x 142 mm / 138 mm x 138 mm / 115 mm
Installation	115 mm
Environmental Conditions	
Operating / Storage Temperature	10 °C to 60 °C / - 20 °C to 70 °C
Dimensions	135 mm x 135 mm x 121 mm (w x h x d)
Degree of Protection	IP 54
Safety	
	pursuant to EN 50178, Class II and EN 61010-1, EN50081-1, EN50082-2, CE conformity